

90 Series Positioning Tables



Introduction	D-2
Ordering Guide	D-4
Specifications	D-5
Dimensions	D-6
Linear Bearing Load Capacity	D-10
Screw Travel Life	D-11
Thrust Capacity (axial load)	D-12
Table Deflection	D-13
Multiple Axis Configurations	D-14
EOT & Home Switches	D-15
Screw Options	D-18
Motor Couplings	D-26
Motor Mount Options	D-28
Power-off Electric Brakes	D-30
Linear & Rotary Encoders	D-31

Single or Multiple Axis

LINTECH's 90 series positioning tables offer precision performance and design flexibility for use in a wide variety of Motion Control applications.

- ❑ *Welding*
- ❑ *Test Stands*
- ❑ *Part Insertion*
- ❑ *Laser Positioning*
- ❑ *Liquid Dispensing*
- ❑ *Semiconductor Processing*
- ❑ *Gluing*
- ❑ *Pick & Place*
- ❑ *Part Scanning*
- ❑ *Inspection Stations*
- ❑ *General Automation*

Quality Construction

LINTECH's 90 series tables are designed with a low friction, preloaded, recirculating linear ball bearing system, which rides on a precision ground linear rails. The linear rails are mounted to a precision machined aluminum base, which offers a rigid support over the entire travel of the table's carriage. The load is mounted to a precision machined aluminum carriage, which has threaded stainless steel inserts for high strength and wear life. There are 50 different acme & ball screw options, that offer high efficiencies and long life at an economical price. These tables are designed to allow for numerous options. They include EOT & Home switches, linear & rotary encoders, power-off electric brakes, motor wrap packages and versatile mounting brackets for multiple axis applications.

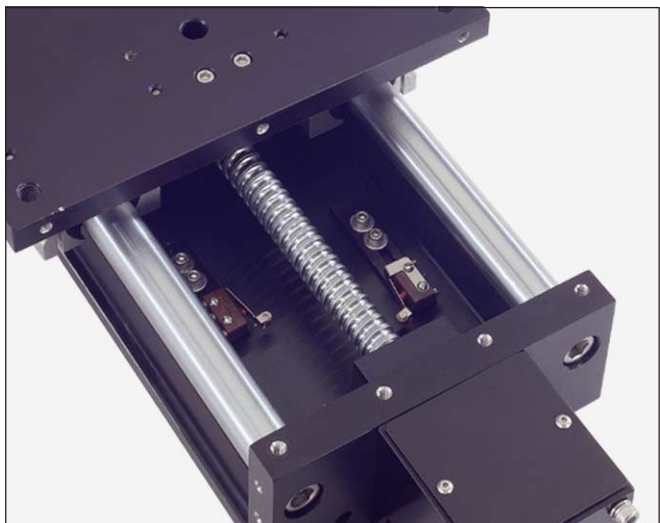

Available Options

Acme Screws & Ball Screws

An assortment of acme screws and ball screws can be installed in the 90 series tables, providing solutions to load back driving, high duty cycle, high speed, extreme smoothness, and sensitive positioning applications.

Vertical Angle Brackets

Optional vertical angle brackets can be mounted directly to the top of various *LINTECH* positioning tables, thus providing for easy multiple axis configurations.

Waycovers

For operator protection, these tables can be fitted with a protective bellows. The entire length of the lead screw and linear bearing system will be covered.

End of Travel and Home Switches

The 90 series tables can be provided with end of travel (EOT) and home switches mounted and wired for each axis. Most position controllers can utilize the EOT switches to stop carriage motion when the extreme table travel has been reached in either direction. The home switch provides a known mechanical location on the table.

Linear and Rotary Encoders

Incremental encoders can be mounted to the table in order to provide positional data back to either a motion controller, or a digital display.

Motor Adapter Brackets

NEMA 23, NEMA 34, or any metric mount motor can be mounted to a 90 series positioning table with the use of adapter brackets.

Turcite Nut With Rolled Ball Screw

This solid polymer nut has no rolling elements in it, and performs very similar to an acme nut. It can provide smoother motion & less audible noise than most ball nuts, and is ideal for corrosive & vertical applications.

Other

The 90 series tables can accommodate **chrome plated linear bearings, rails, & screws** for corrosive environment applications, **power-off electric brakes** for load locking applications, **motor wrap packages** for space limited applications, and a **hand crank** for manually operated applications.

Standard Features - 90 Series

- ❑ Compact 8.0 inches (203 mm) wide by 2.930 inches (74 mm) tall
- ❑ Travel lengths from 6 inches (150 mm) to 60 inches (1520 mm)
- ❑ Threaded stainless steel inserts in carriage for load mounting
- ❑ 0° F to +185° F (-18° C to +85° C) operating temperature
- ❑ 2 rail, 4 bearing, 6 & 12 inch long carriages
- ❑ Recirculating linear ball bearing system
- ❑ Precision ground round rail design

90-WC0 Series



90-WC1 Series



Options - 90 Series

- ❑ Chrome plated linear bearings, rails and screws
- ❑ End of travel (EOT) and home switches wired
- ❑ AUTOCAD® drawings available upon request
- ❑ Adapter brackets for non-NEMA motors
- ❑ Linear and rotary incremental encoders
- ❑ NEMA 23 & 34 motor wrap packages
- ❑ NEMA 34 adapter bracket
- ❑ Power-off electric brakes
- ❑ Vertical angle bracket
- ❑ Turcite nut option
- ❑ Motor couplings
- ❑ Hand crank
- ❑ Ball screws:

Rolled - Non-preloaded & Preloaded Nuts:

- 0.625 inch diameter, 0.200 inch lead
- 0.625 inch diameter, 1.000 inch lead
- 0.750 inch diameter, 0.200 inch lead
- 0.750 inch diameter, 0.500 inch lead
- 1.000 inch diameter, 0.250 inch lead
- 1.000 inch diameter, 0.500 inch lead
- 1.000 inch diameter, 1.000 inch lead

Precision - Non-preloaded & Preloaded Nuts:

- 0.625 inch diameter, 0.200 inch lead
- 16 mm diameter, 5 mm lead
- 16 mm diameter, 10 mm lead
- 16 mm diameter, 16 mm lead
- 0.750 inch diameter, 0.200 inch lead
- 20 mm diameter, 5 mm lead
- 20 mm diameter, 20 mm lead

Ground - Preloaded Nuts Only:

- 0.625 inch diameter, 0.200 inch lead
- 16 mm diameter, 5 mm lead
- 16 mm diameter, 16 mm lead

- ❑ Acme screws:

Rolled - Non-preloaded & Preloaded Nuts:

- 0.625 inch diameter, 0.100 inch lead
- 0.625 inch diameter, 0.200 inch lead

9 **06** **06** - **WC0** - **1** - **S005** - **M02** - **C155** - **L01** - **E00** - **B00**

Table Series

Carriage Length

06 - 6 inches **12** - 12 inches

Travel Length (see pages D-6 & D-8)

06 - 6 to 60 inches

Waycovers

WC0 - with no waycovers **WC1** - with waycovers

Carriage Inserts (see pages D-7 & D-9)

1 - English mount **2** - Metric mount

Screw Options (see pages D-18 to D-25)

Rolled ball screws

S005 - .625 x .200 NPL
S006 - .625 x .200 PL
S007 - .625 x .200 NPL(T)
S008 - .625 x .200 PL(T)
S009 - .625 x 1.000 NPL
S010 - .625 x 1.000 PL
S011 - .625 x 1.000 NPL(T)
S012 - .625 x 1.000 PL(T)
S013 - .750 x .200 NPL
S014 - .750 x .200 PL
S015 - .750 x .200 NPL(T)
S016 - .750 x .200 PL(T)
S017 - .750 x .500 NPL
S018 - .750 x .500 PL
S019 - .750 x .500 NPL(T)
S020 - .750 x .500 PL(T)

Rolled ball screws

S021 - 1.000 x .250 NPL
S022 - 1.000 x .250 PL
S023 - 1.000 x .250 NPL(T)
S024 - 1.000 x .250 PL(T)
S025 - 1.000 x .500 NPL
S026 - 1.000 x .500 PL
S027 - 1.000 x .500 NPL(T)
S028 - 1.000 x .500 PL(T)
S029 - 1.000 x 1.000 NPL
S030 - 1.000 x 1.000 PL
S031 - 1.000 x 1.000 NPL(T)
S032 - 1.000 x 1.000 PL(T)

Ground ball screws

S212 - .625 x .200 PL
S213 - .625 x .500 PL
S214 - 16 x 5 PL
S215 - 16 x 16 PL

Precision ball screws

S114 - .625 x .200 NPL
S115 - .625 x .200 PL
S116 - 16 x 5 NPL
S117 - 16 x 5 PL
S118 - 16 x 10 NPL
S119 - 16 x 10 PL
S120 - 16 x 16 NPL
S121 - 16 x 16 PL
S122 - .750 x .200 NPL
S123 - .750 x .200 PL
S124 - 20 x 5 NPL
S125 - 20 x 5 PL
S128 - 20 x 20 NPL
S129 - 20 x 20 PL

Rolled acme screws

S300 - .625 x .100 NPL
S301 - .625 x .100 PL
S302 - .625 x .200 NPL
S303 - .625 x .200 PL

S999 - other

Motor Mount (see pages D-7 & D-9, D-28 to D-29)

M00 - none **M02** - NEMA 23 mount (E) **M07** - NEMA 23 (LH) wrap
M01 - hand crank **M03** - NEMA 23 mount (M) **M08** - NEMA 34 (RH) wrap
M99 - other **M04** - NEMA 34 mount (E) **M09** - NEMA 34 (LH) wrap
M05 - NEMA 34 mount (M) **M12** - NEMA 42 (RH) wrap
M06 - NEMA 23 (RH) wrap **M13** - NEMA 42 (LH) wrap

Coupling Options (see pages D-26 to D-27)

C000 - none **C025 to C029** - C100 **C130 to C134** - H100 **C407 to C413** - G100
C999 - other **C048 to C055** - C125 **C155 to C164** - H131 **C435 to C444** - G126

Limit & Home Switches (see pages D-15 to D-17)

L00 - no switches		Mechanical	Reed	Hall	Prox (NPN)	Prox (PNP)
L99 - other	EOT & home switches	L01	L04	L07	L10	L13
	EOT switches only	L02	L05	L08	L11	L14
	home switch only	L03	L06	L09	L12	L15

Encoder Options (see page D-31)

E00 - none **E02** - rotary (1000 lines/rev) **E10** - linear (2500 lines/inch) **E99** - other
E01 - rotary (500 lines/rev) **E03** - rotary (1270 lines/rev) **E11** - linear (250 lines/mm)

Power-off Brakes (see page D-30)

B00 - none **B01** - 24 VDC **B02** - 90 VDC **B99** - other

(E) - English Interface (NPL) - Non Preloaded
(LH) - Left Hand (PL) - Preloaded
(T) - Turcite Nut (M) - Metric Interface (RH) - Right Hand

Specifications subject to change without notice

Specifications

Made in the U.S.A.

Load Capacities		6 inch (4 bearing) Carriage	12 inch (4 bearing) Carriage
Dynamic Horizontal ⁽¹⁾	2 million inches (50 km) of travel	3,300 lbs (1496 kg)	3,300 lbs (1496 kg)
Dynamic Horizontal ⁽¹⁾	50 million inches (1270 km) of travel	1,125 lbs (510 kg)	1,125 lbs (510 kg)
Static Horizontal ⁽¹⁾		5,000 lbs (2268 kg)	5,000 lbs (2268 kg)
Dynamic Roll Moment ⁽¹⁾	2 million inches (50 km) of travel	380 ft-lbs (515 N-m)	380 ft-lbs (515 N-m)
Dynamic Roll Moment ⁽¹⁾	50 million inches (1270 km) of travel	130 ft-lbs (176 N-m)	130 ft-lbs (176 N-m)
Static Roll Moment ⁽¹⁾		575 ft-lbs (780 N-m)	575 ft-lbs (780 N-m)
Dyn. Pitch & Yaw Moment ⁽¹⁾	2 million inches (50 km) of travel	150 ft-lbs (203 N-m)	525 ft-lbs (712 N-m)
Dyn. Pitch & Yaw Moment ⁽¹⁾	50 million inches (1270 km) of travel	51 ft-lbs (69 N-m)	179 ft-lbs (243 N-m)
Static Pitch & Yaw Moment ⁽¹⁾		225 ft-lbs (305 N-m)	790 ft-lbs (1071 N-m)
Each Bearing Dyn. Cap. ⁽¹⁾	2 million inches (50 km) of travel	825 lbs (374 kg)	825 lbs (374 kg)
Each Bearing Dyn. Cap. ⁽¹⁾	50 million inches (1270 km) of travel	282 lbs (128 kg)	282 lbs (128 kg)
Each Bearing Static Load Capacity ⁽¹⁾		1,250 lbs (567 kg)	1,250 lbs (567 kg)
Thrust Force Capacity	10 million screw revolutions	895 lbs (406 kg)	895 lbs (406 kg)
Thrust Force Capacity	500 million screw revolutions	240 lbs (109 kg)	240 lbs (109 kg)
Maximum Acceleration		772 in/sec ² (19,6 m/sec ²)	772 in/sec ² (19,6 m/sec ²)
d₁	Center to center distance (spread) between the two rails	4.500 in (114,3 mm)	4.500 in (114,3 mm)
d₂	Center to center distance (spacing) of the bearings on a single rail	2.500 in (63,5 mm)	8.620 in (218,9 mm)
d_r	Center distance of the bearing to top of carriage plate surface	1.437 in (36,5 mm)	1.437 in (36,5 mm)

D

Other	For Six (6) & Twelve (12) inch Carriages
Table Material	Base, Carriage, End Plates, & Cover Plate option - 6061 anodized aluminum
Linear Rail Material	Case Hardened Steel
Screw Material (see pages D-18 to D-25)	Acme Screw - Stainless Steel
Screw Material (see pages D-18 to D-25)	Rolled Ball, Precision Ball, & Ground Ball - Case Hardened Steel
Straightness	< 0.00016 in/in (< 4,06 microns/25mm)
Flatness	< 0.00016 in/in (< 4,06 microns/25mm)
Orthogonality (multi-axis systems)	< 30 arc-seconds
Friction Coefficient	< 0.01
Motor Mount	NEMA 23 & 34 Mounts, Metric Mounts, Motor Wraps, and Hand Crank Option
Coupling	Three (3) different styles available
Waycover Material	Hypilon Polyester Bellows firmly mounted to carriage & end plates

Footnotes:

(1) Derate value by 50 % when load is applied to the open end of the bearing (such as in moment loads and inverted configurations).

Dimensions & Specifications

- Without Waycovers -

Made in the U.S.A.

Model Number	Travel Length inches (mm)	Table Dimensions inches (mm)		Mounting Dimensions inches (mm)				Screw Length inches (mm)	Table ⁽¹⁾ Weight lbs (kg)
		A	B	C	D	E	M		
90606-WC0	6 (150)	13.25 (336,5)	15.75 (400,0)	10.00 (254,0)	6.00 (152,4)	4.00 (101,6)	6	14.94 (379,4)	13.3 (6,0)
90612-WC0	12 (300)	19.25 (488,9)	21.75 (552,4)	16.00 (406,4)	See Detail 1		8	20.94 (531,9)	16.8 (7,6)
90618-WC0	18 (455)	25.25 (641,3)	27.75 (704,8)	22.00 (558,8)	See Detail 2		10	26.94 (684,3)	20.0 (9,1)
90624-WC0	24 (600)	31.25 (793,7)	33.75 (857,2)	28.00 (711,2)	See Detail 3		14	32.94 (836,7)	31.0 (14,1)
90630-WC0	30 (760)	37.25 (946,1)	39.75 (1009,6)	34.00 (863,6)	See Detail 4		16	38.94 (989,1)	36.0 (16,3)
90636-WC0	36 (910)	43.25 (1098,5)	45.75 (1162,0)	40.00 (1016,0)	See Detail 5		18	44.94 (1141,5)	41.0 (18,6)
90648-WC0	48 (1215)	55.25 (1403,3)	57.75 (1466,8)	52.00 (1320,8)	See Detail 6		24	56.94 (1446,3)	51.0 (23,1)
90660-WC0	60 (1520)	67.25 (1708,1)	69.75 (1771,6)	64.00 (1625,6)	See Detail 7		28	68.94 (1751,1)	61.0 (27,7)
91206-WC0	6 (150)	19.25 (488,9)	21.75 (552,4)	16.00 (406,4)	See Detail 1		8	20.94 (531,9)	21.3 (9,7)
91212-WC0	12 (300)	25.25 (641,3)	27.75 (704,8)	22.00 (558,8)	See Detail 2		10	26.94 (684,3)	23.5 (10,7)
91218-WC0	18 (455)	31.25 (793,7)	33.75 (857,2)	28.00 (711,2)	See Detail 3		14	32.94 (836,7)	33.0 (15,0)
91224-WC0	24 (600)	37.25 (946,1)	39.75 (1009,6)	34.00 (863,6)	See Detail 4		16	38.94 (989,1)	38.0 (17,2)
91230-WC0	30 (760)	43.25 (1098,5)	45.75 (1162,0)	40.00 (1016,0)	See Detail 5		18	44.94 (1141,5)	43.0 (19,5)
91236-WC0	36 (910)	49.25 (1250,9)	51.75 (1466,8)	46.00 (1168,4)	See Detail 6		24	50.94 (1293,9)	48.0 (21,8)
91248-WC0	48 (1215)	61.25 (1555,7)	63.75 (1619,2)	58.00 (1473,2)	See Detail 7		28	62.94 (1598,7)	58.0 (26,3)
91260-WC0	60 (1520)	73.25 (1860,5)	75.75 (1924,0)	70.00 (1778,0)	See Detail 8		30	74.94 (1903,5)	68.0 (30,8)

- 06 = Carriage length is 06 inch (152,4 mm) with 4 bearings; Carriage weight = 5.25 lbs. (2,38 kg)
- 12 = Carriage length is 12 inch (304,8 mm) with 4 bearings; Carriage weight = 8.00 lbs. (3,63 kg)

Footnotes:

(1) Weight shown is with a 0.625 inch (16 mm) diameter screw, a NEMA 23 motor mount [0.34 lbs (0,16 kg)], and a C100 style [0.09 lbs (0,04 kg)] coupling. When using a 0.750 inch (20 mm) diameter screw add 0.042 lbs per inch (0,00075 kg per mm) of screw length for a given model number. When using a 1.000 inch diameter screw add 0.117 lbs per inch (0,0021 kg per mm) of screw length for a given model number.

Dimensions & Specifications

- With Waycovers -

Made in the U.S.A.

Model Number	Travel Length inches (mm)	Table Dimensions inches (mm)		Mounting Dimensions inches (mm)				Screw Length inches (mm)	Table ⁽¹⁾ Weight lbs (kg)
		A	B	C	D	E	M		
90604-WC1	4.7 (119)	13.25 (336,5)	15.75 (400,0)	10.00 (254)	6.00 (152,4)	4.00 (101,6)	6	14.94 (379,4)	14.2 (6,5)
90609-WC1	9.7 (246)	19.25 (488,9)	21.75 (552,4)	16.00 (406,4)	See Detail 1		8	20.94 (531,9)	18.2 (8,3)
90614-WC1	14.8 (375)	25.25 (641,3)	27.75 (704,8)	22.00 (558,8)	See Detail 2		10	26.94 (684,3)	21.8 (9,9)
90619-WC1	19.8 (502)	31.25 (793,7)	33.75 (857,2)	28.00 (711,2)	See Detail 3		14	32.94 (836,7)	33.2 (15,1)
90624-WC1	24.9 (632)	37.25 (946,1)	39.75 (1009,6)	34.00 (863,6)	See Detail 4		16	38.94 (989,1)	38.6 (17,5)
90629-WC1	29.9 (759)	43.25 (1098,5)	45.75 (1162,0)	40.00 (1016,0)	See Detail 5		18	44.94 (1141,5)	44.0 (20,0)
90640-WC1	40.2 (1021)	55.25 (1403,3)	57.75 (1466,8)	52.00 (1320,8)	See Detail 6		24	56.94 (1446,3)	54.9 (24,9)
90650-WC1	50.2 (1275)	67.25 (1708,1)	69.75 (1771,6)	64.00 (1625,6)	See Detail 7		28	68.94 (1751,1)	65.7 (29,8)
91204-WC1	4.7 (119)	19.25 (488,9)	21.75 (552,4)	16.00 (406,4)	See Detail 1		8	20.94 (531,9)	22.3 (10,1)
91209-WC1	9.7 (246)	25.25 (641,3)	27.75 (704,8)	22.00 (558,8)	See Detail 2		10	26.94 (684,3)	24.9 (11,3)
91214-WC1	14.8 (375)	31.25 (793,7)	33.75 (857,2)	28.00 (711,2)	See Detail 3		14	32.94 (836,7)	34.8 (15,8)
91219-WC1	19.8 (502)	37.25 (946,1)	39.75 (1009,6)	34.00 (863,6)	See Detail 4		16	38.94 (989,1)	40.2 (18,2)
91224-WC1	24.9 (632)	43.25 (1098,5)	45.75 (1162,0)	40.00 (1016,0)	See Detail 5		18	44.94 (1141,5)	45.6 (20,7)
91229-WC1	29.9 (759)	49.25 (1250,9)	51.75 (1466,8)	46.00 (1168,4)	See Detail 6		24	50.94 (1293,9)	51.0 (23,1)
91240-WC1	40.2 (1021)	61.25 (1555,7)	63.75 (1619,2)	58.00 (1473,2)	See Detail 7		28	62.94 (1598,7)	61.9 (28,1)
91250-WC1	50.2 (1275)	73.25 (1860,5)	75.75 (1924,0)	70.00 (1778,0)	See Detail 8		30	74.94 (1903,5)	72.7 (33,0)

- 06 = Carriage length is 06 inch (152,4 mm) with 4 bearings; Carriage weight = 5.75 lbs. (2,61 kg)
- 12 = Carriage length is 12 inch (304,8 mm) with 4 bearings; Carriage weight = 8.75 lbs. (3,97 kg)

Footnotes:

(1) Weight shown is with a 0.625 inch (16 mm) diameter screw, a NEMA 23 motor mount [0.34 lbs (0,16 kg)], and a C100 style [0.09 lbs (0,04 kg)] coupling. When using a 0.750 inch (20 mm) diameter screw add 0.042 lbs per inch (0,00075 kg per mm) of screw length for a given model number. When using a 1.000 inch diameter screw add 0.117 lbs per inch (0,0021 kg per mm) of screw length for a given model number.

Linear Bearing Load Capacities

The following equation, and graphs, can be used to help determine the linear bearing life, and load capacity, of a 90 series positioning table.

$$L = \left[\frac{R}{F \times S} \right]^3 \times B$$

- L** = calculated travel life (millions of inches or Km)
- R** = rated dynamic load capacity of carriage (or each bearing) at 2 million inches of travel or 50 Km
- F** = user applied load
- S** = safety factor (1 to 8)
- B** = either 2 (for millions of inches) or 50 (for Km)

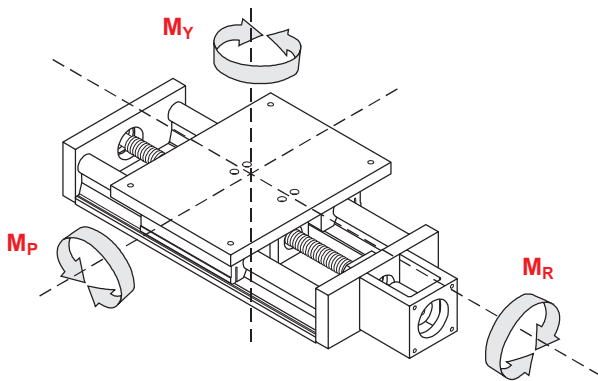

Dynamic Horizontal Load Capacity

Load Centered on Carriage

travel life millions of inches (Km)	6 inch Carriage		12 inch Carriage	
	lbs (kg)	lbs (kg)	lbs (kg)	lbs (kg)
2 (50)	3,300 (1496)	3,300 (1496)	3,300 (1496)	3,300 (1496)
50 (1270)	1,125 (510)	1,125 (510)	1,125 (510)	1,125 (510)
100 (2540)	885 (401)	885 (401)	885 (401)	885 (401)

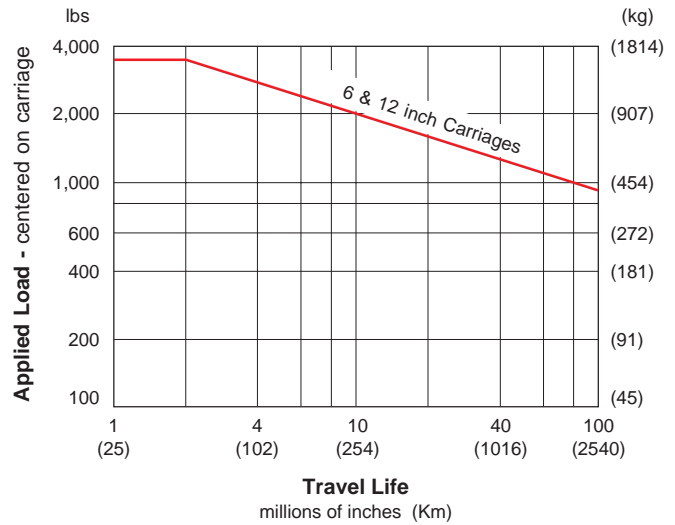

Dynamic Moment Load (M_R) Capacity

Load applied away from Carriage Center

travel life millions of inches (Km)	6 inch Carriage		12 inch Carriage	
	ft-lbs (N-m)	ft-lbs (N-m)	ft-lbs (N-m)	ft-lbs (N-m)
2 (50)	380 (515)	380 (515)	380 (515)	380 (515)
50 (1270)	130 (176)	130 (176)	130 (176)	130 (176)
100 (2540)	102 (138)	102 (138)	102 (138)	102 (138)

Ratings are based on d₃ = 12 inches (305 mm) & d₄ = 0

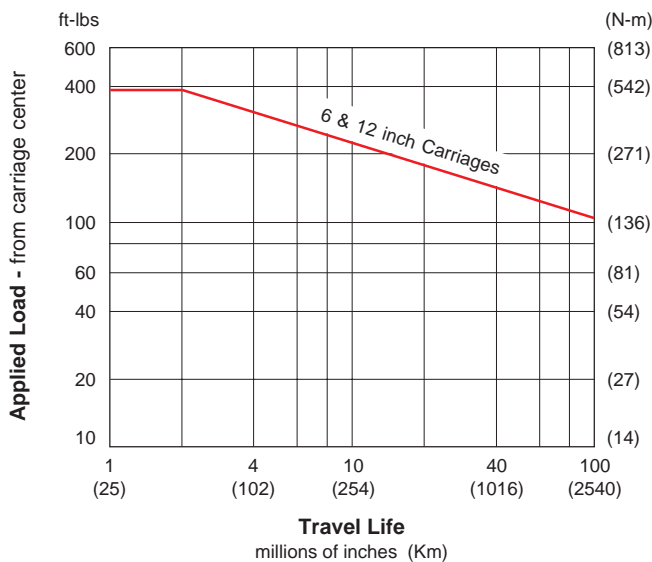

Dynamic Moment Load (M_P & M_Y) Capacity

Load applied away from Carriage Center

travel life millions of inches (Km)	6 inch Carriage		12 inch Carriage	
	ft-lbs (N-m)	ft-lbs (N-m)	ft-lbs (N-m)	ft-lbs (N-m)
2 (50)	150 (203)	525 (712)	525 (712)	525 (712)
50 (1270)	51 (69)	179 (243)	179 (243)	179 (243)
100 (2540)	41 (55)	141 (191)	141 (191)	141 (191)

Ratings are based on d₃ = 0 & d₄ = 12 inches (305 mm)

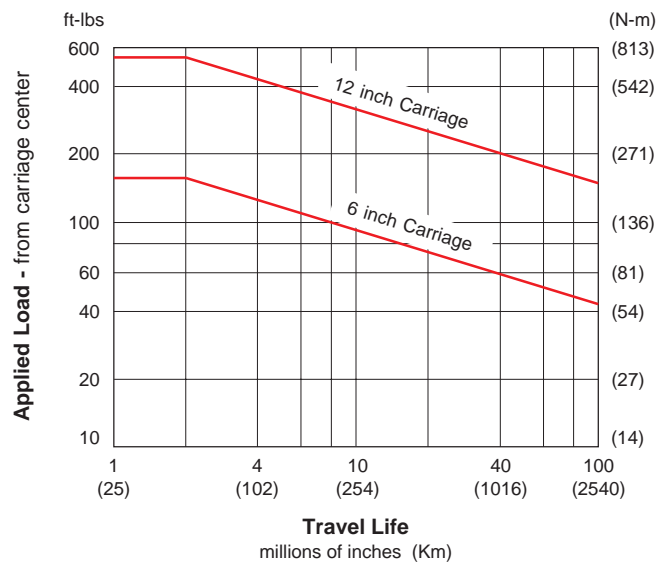

Specifications subject to change without notice

Screw Travel Life

The life of an acme or ball screw can be estimated by evaluating the load applied to the nut. The applied load "as seen by the screw nut" depends upon the table orientation. Typically, the extra force acting upon the screw nut during the acceleration interval is offset by a reduction in force during the deceleration interval. Therefore, evaluating the life of the screw nut at a constant speed is adequate. The life of the screw nut may not be the limiting element for a given application. See page D-12 for load/life capacity of the screw end support bearings.

Horizontal Application

$$F = (W \times \mu) + E$$

Vertical Application

$$F = W + E$$

$$L = \left[\frac{R}{F \times S} \right]^3 \times B$$

- B** = either 1 (for millions of inches) or 25 (for Km)
- E** = externally applied extra forces
- F** = applied axial load (*as seen by screw nut*)
- L** = calculated travel life (millions of inches or Km)
- R** = rated dynamic load capacity of screw nut at 1 million inches of travel or 25 Km (see pages D-21 to D-25)
- S** = safety factor (1 to 8)
- W** = user mounted load weight to carriage
- μ** = coefficient of friction for linear bearing system (0.01)

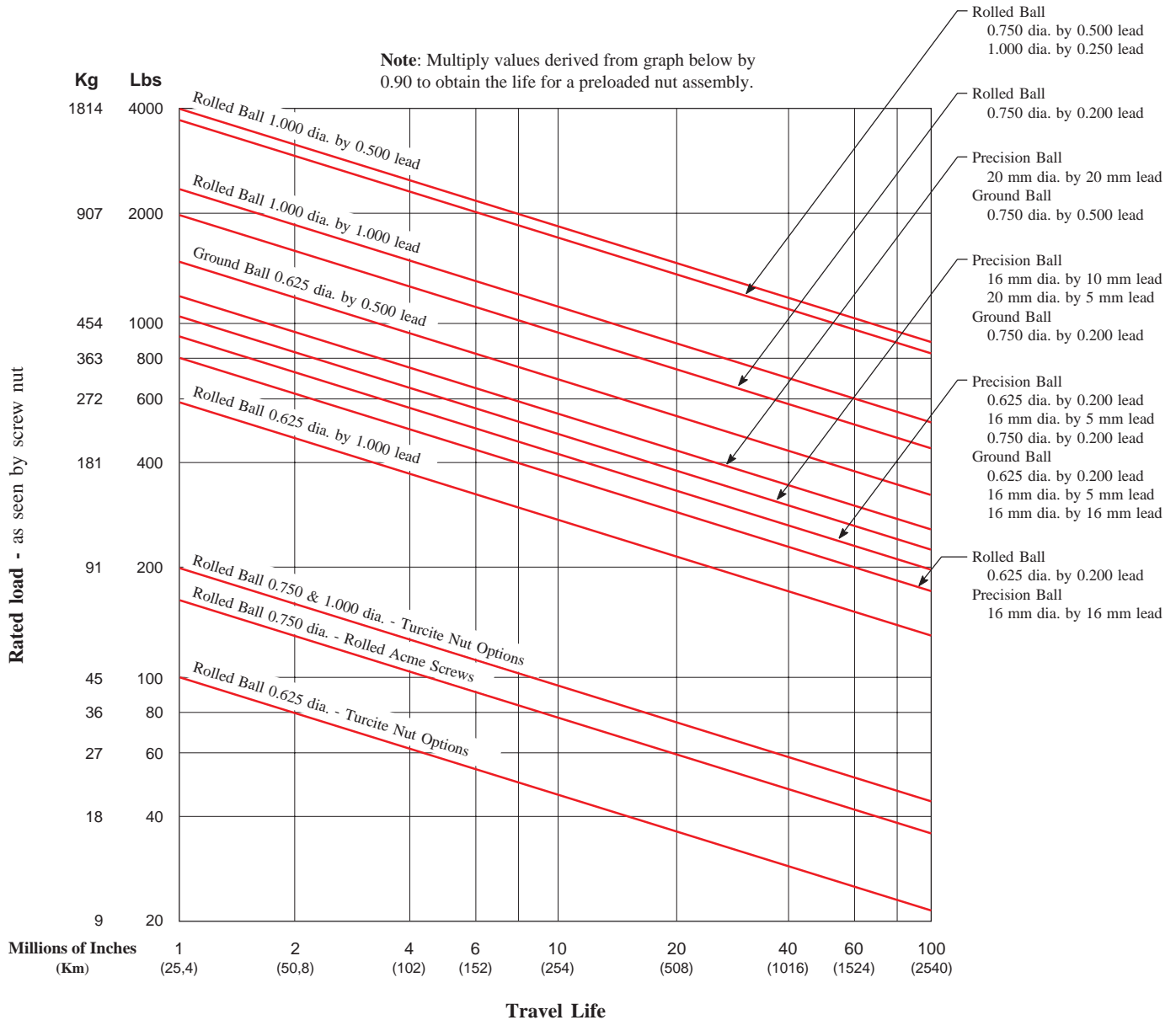

Specifications subject to change without notice

Thrust Capacity (axial load)

The life of the screw end support bearings can be estimated by evaluating the applied axial (thrust) load. The applied load "as seen by the bearings" depends upon the table orientation. Typically, the extra force acting upon the bearings during the acceleration interval is offset by a reduction in force during the deceleration interval. Therefore, evaluating the life of the bearings at a constant speed is adequate. The life of the screw end support bearings may not be the limiting element for a given application. See page D-11 for load/life capacity of acme and ball screw nuts.

$$L = \left[\frac{R}{F \times S} \right]^3 \times B$$

- B** = 2 (for millions of revolutions)
- E** = externally applied extra forces
- F** = applied axial load (*as seen by the bearings*)
- L** = calculated life (millions of revolutions)
- R** = dynamic load capacity of bearings at 2 million screw revolutions (see below)
- S** = safety factor (1 to 8)
- W** = user mounted load weight to carriage
- μ** = coefficient of friction for linear bearing system (0.01)

Horizontal Application

$$F = (W \times \mu) + E$$

Vertical Application

$$F = W + E$$

Screw End Supports		Number of Screw Revolutions millions of screw revolutions						
		Static	1	2	10	50	100	500
Thrust Capacity	lbs (kg)	1,725 (782)	1,725 (782)	1,530 (694)	895 (406)	525 (238)	415 (188)	240 (109)

Note: Multiply screw revolutions by the screw lead in order to convert to inches (or mm) traveled by the nut.

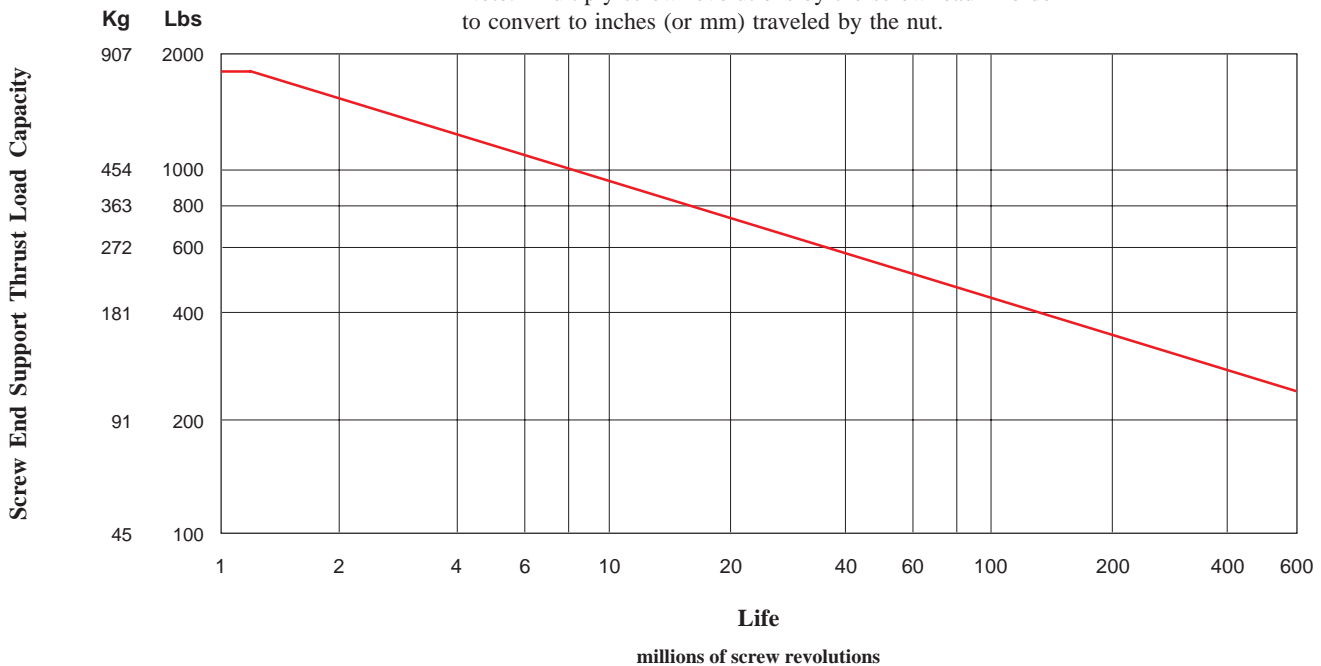

Moment of Inertia Values

The "moment of inertia" of an object is a gauge of the strength of that object to resist deflecting when used in an application or orientation where deflection might occur. The higher an I value relates to a lower amount of deflection.

$I = 0.28 \text{ in}^4 (1.16 \times 10^5 \text{ mm}^4)$

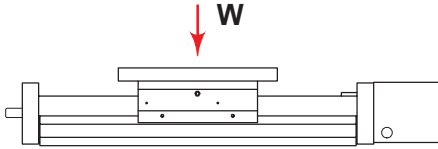

$I = 4.81 \text{ in}^4 (20.00 \times 10^5 \text{ mm}^4)$

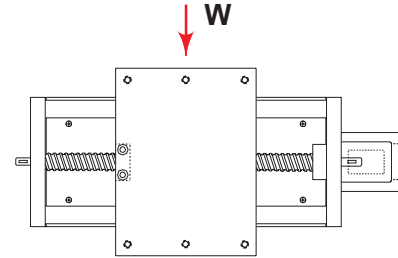

D

Multi-Axis Configurations

LINTECH can provide various adapter plates, and vertical adapter brackets, to facilitate the construction of X-Y, X-Z, and X-Y-Z multiple axis configurations. There are literally hundreds of different possible configurations available. See below for some of the more common systems. *LINTECH* has a great deal of experience in dealing with multiple axis configurations. Sometimes different standard table series can be mounted together to form a custom system. Other times, a complete custom assembly is created, due to the application details. Contact *LINTECH* for more information.

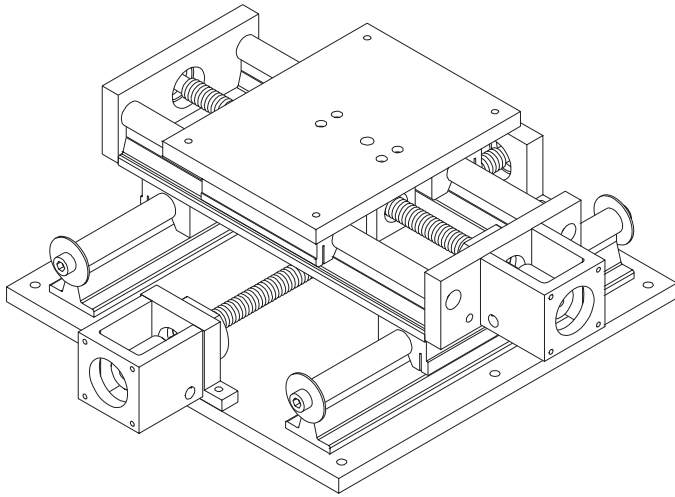
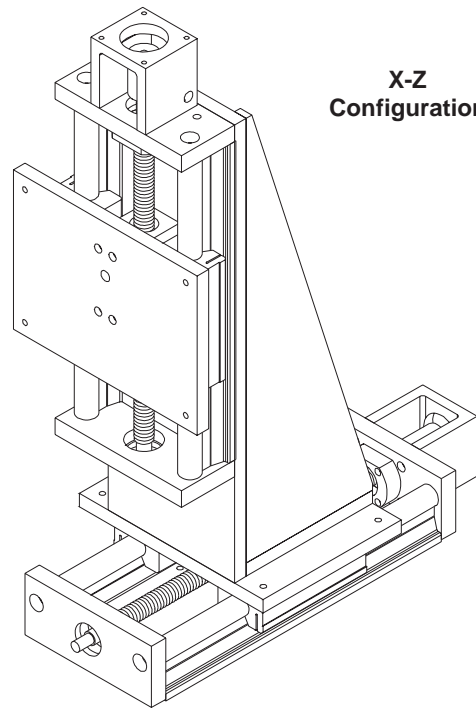
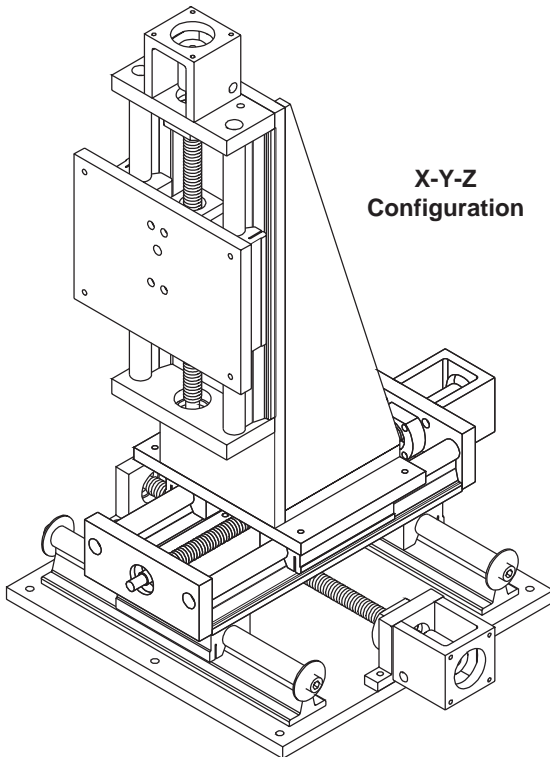
**X-Y
Configuration****X-Z
Configuration****X-Y-Z
Configuration**

End of Travel (EOT) Switches & Home Switch

LINTECH provides several options for EOT & home switches. One style uses mechanically actuated switches, while other styles use "non-contact" versions. When ordered with a *LINTECH* 90 series table, each switch is mounted to the base of the table, while the actuating cams are mounted to the carriage assembly. Each switch is mounted to a plate that allows for a 0.625 inch (16 mm) adjustment range. The switches are pre-wired by *LINTECH* for easy interfacing to the users Motion Controller.

End of Travel (EOT) Switches

End of travel (EOT) switches can be utilized by a motion controller to stop carriage motion, thereby preventing any damage to personnel, table carriage, or user mounted load if the extreme end of travel has been reached by the carriage. There are two EOT switches mounted to the side of the table, one on each end. The CCW switch is mounted at the motor mount end, while the CW switch is located at the opposite end of the table. *LINTECH* provides normally closed (NC) end of travel switches. This provides for a power-off fail safe system, where the position controller can detect broken wires. *It is highly recommended that any positioning table used with a position controller, should have end of travel switches installed for protection of personnel, table carriage, and user mounted load.*

Home Switch

The home switch can be utilized by a motion controller as a known fixed mechanical location on the positioning table. The switch is located on the opposite side of the EOT switches, at the motor mount end, and is a normally open (NO) switch.

Switch Locations

The following diagram shows the locations of the switches when ordered from *LINTECH*.

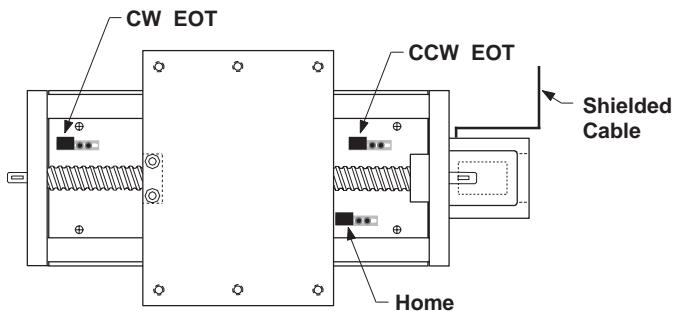

Note: For the 90-WC0 series, EOT switches are normally located 0.375 inches (9,5 mm) inward from the maximum travel hard stops. Thus, reducing overall system travel by 0.750 inches (19,1 mm) from listed table travel for each model #. For the 90-WC1 series there is NO reduction of listed travel length when using EOT switches.

Note: Each switch bracket has a 0.625 inch (16 mm) adjustment range

Switch Type	Cost	Repeatability inches (microns)	Actuated	Power Supply Required	Activation Area inches (mm)	Comments
mechanical	least expensive	+/- 0.0002 (5)	mechanical	No	1.75 (44,45)	for most applications
reed	slightly more	+/- 0.0020 (50)	magnetic	No	0.30 (7,62)	for non-contact & low repeatable applications
hall effect	medium priced	+/- 0.0002 (5)	magnetic	Yes	0.32 (8,13)	for non-contact and wash down applications
proximity	most expensive	+/- 0.0002 (5)	non-magnetic	Yes	1.75 (44,45)	for non-contact, high speed, & wash down applications

Note: The repeatability of any switch is dependent upon several factors: carriage speed, accel rate, load weight, switch style, and the position controller. *LINTECH*'s ratings are based upon a carriage speed of 0.5 inches/sec (12.7 mm/sec) and a no load condition.

End of Travel (EOT) Switches & Home Switch

Mechanical Switches

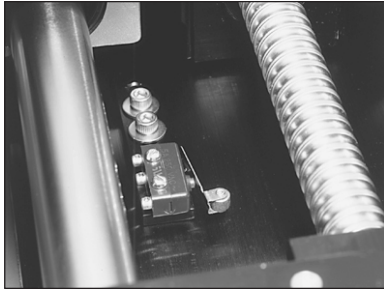

- Repeatability : +/- 0.0002 inch (5 microns)
- Electrical : 5 amps @ 125 VAC
1 amp @ 85 VDC
- Activation Style : mechanical cam
- Activation Area : 1.75 inches (44,45 mm) of travel
- Temperature Range : - 25° C to + 85° C
- Environment : non wash down
- Added Table Width : none
- Individual Switch Wiring : none

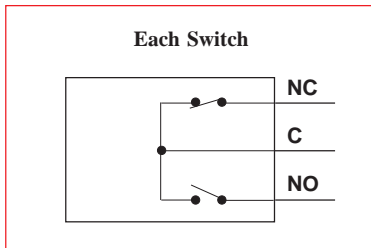

Standard *LINTECH* Wiring : from table end plate, 10 foot (3 m) shielded cable, 6 conductor, 24 AWG, unterminated leads
(provided when switch option is ordered with any table)

Wire Color	Description
Black	CW EOT
Blue	CW Common
Red	CCW EOT
White	CCW Common
Brown	HOME
Green	HOME Common
Silver	Shield

Note: Hermetically sealed mechanical switches can be ordered as an option. This may be desired for "wash down" applications. Contact *LINTECH*.

Non-Contact Reed Switches

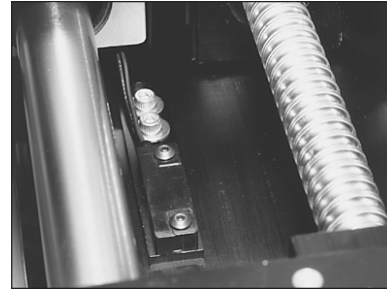

- Repeatability : +/- 0.0020 inch (50 microns)
- Electrical : 1.0 amps @ 125 VAC
0.5 amps @ 100 VDC
- Activation Style : magnetic
- Activation Area : 0.30 inches (7,62 mm) of travel
- Temperature Range : - 10° C to + 60° C
- Environment : non wash down
- Added Table Width : none
- Individual Switch Wiring : 12 inch (305 mm) leads

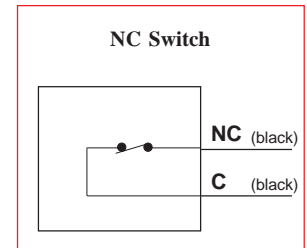
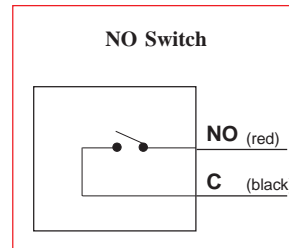

Standard *LINTECH* Wiring : from table end plate, 10 foot (3 m) shielded cable, 6 conductor, 24 AWG, unterminated leads
(provided when switch option is ordered with any table)

Wire Color	Description
Black	CW EOT
Blue	CW Common
Red	CCW EOT
White	CCW Common
Brown	HOME
Green	HOME Common
Silver	Shield

- CW - Clockwise
- CCW - Counter Clockwise
- EOT - End of Travel
- NC - Normally Closed
- NO - Normally Open

Specifications subject to change without notice

End of Travel (EOT) Switches & Home Switch

Non-Contact Hall Effect Switches



- Repeatability : +/- 0.0002 inch (5 microns)
- Electrical : 5 - 24 VDC
15 mA - power input
25 mA max - signal
- Actuation Style : magnetic
- Activation Area : 0.32 inches (8,13 mm) of travel
- Temperature Range : - 10° C to + 60° C
- Environment : wash down
- Added Table Width : none
- Individual Switch Wiring : 12 inch (305 mm) leads

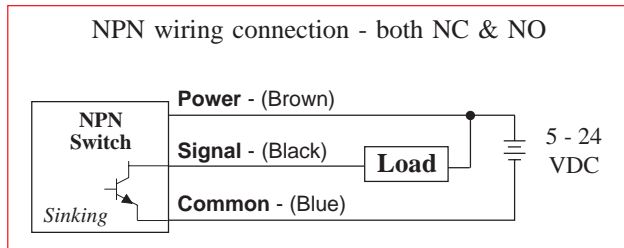

Standard *LINTECH* Wiring : from table end plate,
(provided when switch option is ordered with any table) 10 foot (3 m) shielded cable; 9 conductor, 24 AWG, unterminated leads

Wire Color	Description		
Brown	CW Power	(brown)	switch NC
Black	CW EOT	(black)	
Blue	CW Common	(blue)	
Red	CCW Power	(brown)	switch NC
White	CCW EOT	(black)	
Green	CCW Common	(blue)	
Orange	Home Power	(brown)	switch NO
Yellow	Home	(black)	
Grey	Home Common	(blue)	
Silver	Shield		

Non-Contact Proximity Switches

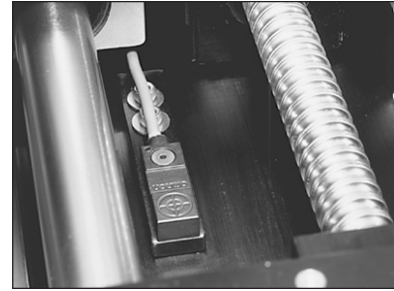

- Repeatability : +/- 0.0002 inch (5 microns)
- Electrical : 10 - 28 VDC
15 mA - power input
100 mA max - signal
- Actuation Style : non-magnetic cam
- Activation Area : 1.75 inches (44,45 mm) of travel
- Temperature Range : - 25° C to + 75° C
- Environment : IEC IP67 wash down
- Added Table Width : none
- Individual Switch Wiring : 6.5 foot (2 m) cable for NPN
3.3 foot (1 m) cable for PNP

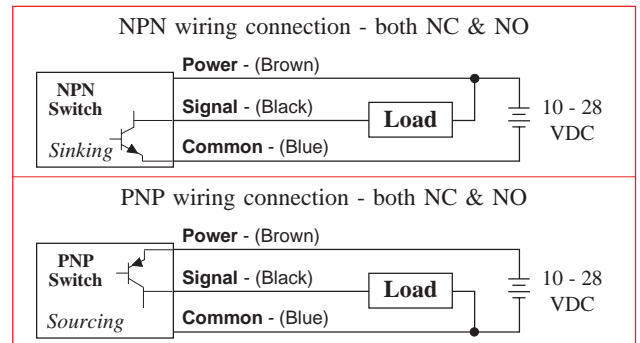

Standard *LINTECH* Wiring : from table end plate,
(provided when switch option is ordered with any table) 10 foot (3 m) shielded cable; 9 conductor, 24 AWG, unterminated leads

Wire Color	Description		
Brown	CW Power	(brown)	switch NC
Black	CW EOT	(black)	
Blue	CW Common	(blue)	
Red	CCW Power	(brown)	switch NC
White	CCW EOT	(black)	
Green	CCW Common	(blue)	
Orange	Home Power	(brown)	switch NO
Yellow	Home	(black)	
Grey	Home Common	(blue)	
Silver	Shield		

Specifications subject to change without notice

Screws - Acme & Ball

Acme screws use a turcite (polymer), or bronze nut. The nut threads ride in the matching acme screw threads, much like the ordinary nut and bolt system. This produces a higher friction (lower efficiency) system than a ball screw assembly, since there are no rolling elements between the nut and the acme screw threads. For applications requiring low speeds, noise and duty cycles, an acme screw works fine. Also, an acme screw is a good choice for most vertical applications, as it typically prevents back driving of the attached load.

Ball screws are the screw of choice for high duty cycle, high speed, and long life applications. The 90 series tables can be fitted with an assortment of ball screws. The ball screw nut uses one or more circuits of recirculating steel balls which roll between the nut and ball screw grooves, providing an efficient low friction system. Using a higher

lead ball screw (for example a 0.500 inch lead instead of a 0.200 inch lead) will offer greater carriage speed for applications requiring rapid traverse, or fast, short incremental moves. Low wear and long life are key features of a ball screw system.

LINTECH provides three different ball screw configurations. The rolled ball screw system utilizes a tapped nut with a standard accuracy grade rolled screw. The precision ball screw system utilizes a ground nut with a higher accuracy grade rolled screw. The ground ball screw system utilizes a ground nut with a high accuracy precision ground screw.

Some screws are available with preloaded nuts. The preloaded nut assembly offers high *bidirectional* repeatability by eliminating backlash.

Consideration	Acme Screw	Ball Screws			Comments
		Rolled	Precision	Ground	
Audible noise	least audible noise	most audible noise	less audible noise than rolled screw	less audible noise than precision screw	Acme: no rolling elements provide for quiet operation. Ball: recirculating balls in nut assembly transmit audible noise during motion; due to more accurate machining procedures - precision & ground ball screws are quieter than rolled ball screws.
Back Driving Loads	may prevent back driving	can easily back drive a load	can easily back drive a load	can easily back drive a load	Acme: good for light loads & vertical applications. Ball: recirculating balls in nut assembly produce a low friction system; vertical applications may require a brake to hold the load when no power is applied to the motor.
Backlash non-preloaded nut	will increase with wear	constant	constant	constant	Acme: preloaded nut assembly eliminates backlash. Ball: preloaded nut assembly eliminates backlash.
Duty Cycle	low to medium (< 50 %)	high (100 %)	high (100 %)	high (100 %)	Acme: low duty cycle due to high sliding friction. Ball: high duty cycle due to recirculating balls in nut assembly - high efficiency & low friction system.
Life	shorter due to higher friction	long	long	long	Acme: mechanical wear related to duty cycle, load & speed. Ball: minimal wear if operated in proper environment, within load specifications, and periodically lubricated.
Relative - Cost	slightly more than rolled ball	least expensive	slightly more than rolled ball	most expensive	Acme: a little more expensive than the rolled ball screw. Ball: due to more accurate manufacturing procedures precision rolled & ground ball screws are more expensive.
Screw Efficiency	low 40 % -Acme 60 % -Turcite	high (90 %)	high (90 %)	high (90 %)	Acme: low efficiency due to high sliding friction. Ball: high efficiency due to recirculating balls in nut assembly - low friction system.
Smoothness	can be smooth	least smooth	medium smoothness	smoothest	Acme: due to friction can start/stop at very low speeds. Ball: smoothness is constant through a wide speed range; due to more accurate manufacturing procedures precision rolled & ground ball screws are smoother than rolled ball screws.
Speeds	low	high	high	high	Acme: high friction can causes excess heat & wear at high speeds. Ball: recirculating balls in nut provide for a high speed system due to low friction & high efficiency.

Screws - Acme & Ball

90-WC0 series		90-WC1 series		Maximum Safe Table Operating Speed ⁽¹⁾ in/sec (mm/sec)						
Model Number	Travel Length inches (mm)	Model Number	Travel Length inches (mm)	Screw						
				0.625 dia. 0.100 lead	0.625 dia. 0.200 lead	0.625 dia. 0.500 lead	0.625 dia. 1.000 lead	16 mm dia. 5 mm lead	16 mm dia. 10 mm lead	16 mm dia. 16 mm lead
90606	6 (150)	90604	4.7 (119)	5.0 (127)	10.0 (254)	25.0 (635)	50.0 (1270)	9.8 (249)	19.7 (500)	31.5 (800)
90612	12 (300)	90609	9.7 (246)	5.0 (127)	10.0 (254)	25.0 (635)	50.0 (1270)	9.8 (249)	19.7 (500)	31.5 (800)
90618	18 (455)	90614	14.8 (375)	5.0 (127)	10.0 (254)	25.0 (635)	50.0 (1270)	9.8 (249)	19.7 (500)	31.5 (800)
90624	24 (600)	90619	19.8 (502)	3.8 (96)	7.6 (193)	19.0 (483)	38.0 (874)	7.4 (188)	14.8 (376)	23.7 (602)
90630	30 (760)	90624	24.9 (632)	2.7 (69)	5.3 (135)	13.4 (340)	26.7 (625)	5.2 (132)	10.4 (264)	16.7 (424)
90636	36 (910)	90629	29.9 (759)	2.0 (51)	4.0 (102)	9.9 (251)	19.8 (467)	3.9 (99)	7.7 (196)	12.4 (315)
90648	48 (1215)	90640	40.2 (1021)	1.2 (30)	2.4 (61)	6.1 (155)	12.2 (292)	2.4 (61)	4.7 (119)	7.6 (193)
90660	60 (1520)	90650	50.2 (1275)	0.8 (20)	1.6 (41)	4.1 (104)	8.2 (198)	1.6 (41)	3.2 (81)	5.1 (130)
91206	6 (150)	91204	4.7 (119)	5.0 (127)	10.0 (254)	25.0 (635)	50.0 (1270)	9.8 (188)	19.7 (500)	31.5 (800)
91212	12 (300)	91209	9.7 (246)	5.0 (127)	10.0 (254)	25.0 (635)	50.0 (1270)	9.8 (249)	19.7 (500)	31.5 (800)
91218	18 (455)	91214	14.8 (375)	3.8 (96)	7.6 (193)	19.0 (483)	38.0 (965)	7.4 (188)	14.8 (376)	23.7 (602)
90824	24 (600)	91219	19.8 (502)	2.7 (69)	5.3 (135)	13.4 (340)	26.7 (678)	5.2 (132)	10.4 (264)	16.7 (424)
91230	30 (760)	91224	24.9 (632)	2.0 (51)	4.0 (102)	9.9 (251)	19.8 (503)	3.9 (99)	7.7 (196)	12.4 (315)
91236	36 (910)	91229	29.9 (759)	1.5 (38)	3.1 (79)	7.6 (193)	15.3 (389)	3.0 (76)	6.0 (152)	9.5 (241)
91248	48 (1215)	91240	40.2 (1021)	1.0 (25)	2.0 (51)	4.9 (124)	9.9 (251)	1.9 (48)	3.9 (99)	6.2 (157)
91260	60 (1520)	91250	50.2 (1275)	0.7 (17)	1.4 (35)	3.4 (86)	6.9 (175)	1.3 (33)	2.7 (69)	4.3 (109)

Footnotes:

- (1) These listed speeds are a mechanical limitation. The maximum speed of a positioning table depends on the screw diameter, screw lead, screw length, and the screw end bearing support configuration. *LINTECH* uses a fixed-simple screw end bearing support configuration in its positioning tables. The correct motor & drive system needs to be selected in order to obtain the above maximum table speeds.

Screws - Acme & Ball

90-WC0 series Model Number	Travel Length inches (mm)	90-WC1 series Model Number	Travel Length inches (mm)	Maximum Safe Table Operating Speed ⁽¹⁾ in/sec (mm/sec)						
				Screw						
				0.750 dia. 0.200 lead	0.750 dia. 0.500 lead	20 mm dia. 5 mm lead	20 mm dia. 20 mm lead	1.000 dia. 0.250 lead	1.000 dia. 0.500 lead	1.000 dia. 1.000 lead
90606	6 (150)	90604	4.7 (119)	10.0 (254)	25.0 (635)	9.8 (249)	39.3 (998)	12.5 (317)	25.0 (635)	50.0 (1270)
90612	12 (300)	90609	9.7 (246)	10.0 (254)	25.0 (635)	9.8 (249)	39.3 (998)	12.5 (317)	25.0 (635)	50.0 (1270)
90618	18 (455)	90614	14.8 (375)	10.0 (254)	25.0 (635)	9.8 (249)	39.3 (998)	12.5 (317)	25.0 (635)	50.0 (1270)
90624	24 (600)	90619	19.8 (502)	9.1 (208)	22.7 (577)	9.0 (229)	35.9 (912)	12.5 (317)	25.0 (635)	50.0 (1270)
90630	30 (760)	90624	24.9 (632)	6.4 (163)	16.0 (406)	6.3 (147)	25.3 (643)	10.5 (267)	20.9 (531)	41.8 (1062)
90636	36 (910)	90629	29.9 (759)	4.7 (119)	11.9 (302)	4.7 (119)	18.8 (478)	7.8 (198)	15.5 (394)	31.0 (787)
90648	48 (1215)	90640	40.2 (1021)	2.9 (74)	7.3 (185)	2.9 (74)	11.5 (292)	4.7 (119)	9.5 (241)	19.0 (483)
90660	60 (1520)	90650	50.2 (1275)	2.0 (51)	4.9 (124)	1.9 (48)	7.8 (198)	3.2 (81)	6.4 (163)	12.8 (325)
91206	6 (150)	91204	4.7 (119)	10.0 (254)	25.0 (635)	9.8 (249)	39.3 (998)	12.5 (317)	25.0 (635)	50.0 (1270)
91212	12 (300)	91209	9.7 (246)	10.0 (254)	25.0 (635)	9.8 (249)	39.3 (998)	12.5 (317)	25.0 (635)	50.0 (1270)
91218	18 (455)	91214	14.8 (375)	9.1 (231)	22.7 (577)	9.0 (229)	35.9 (912)	12.5 (317)	25.0 (635)	50.0 (1270)
90824	24 (600)	91219	19.8 (502)	6.4 (163)	16.0 (406)	6.3 (160)	25.3 (643)	10.5 (267)	20.9 (531)	41.8 (1062)
91230	30 (760)	91224	24.9 (632)	4.7 (119)	11.9 (302)	4.7 (119)	18.8 (478)	7.8 (198)	15.5 (394)	31.0 (787)
91236	36 (910)	91229	29.9 (759)	3.7 (94)	9.1 (231)	3.6 (91)	14.5 (368)	6.0 (152)	12.0 (305)	23.9 (607)
91248	48 (1215)	91240	40.2 (1021)	2.4 (61)	5.9 (150)	2.3 (58)	9.3 (236)	3.9 (99)	7.7 (196)	15.5 (394)
91260	60 (1520)	91250	50.2 (1275)	1.6 (41)	4.1 (104)	1.6 (41)	6.5 (165)	2.7 (69)	5.4 (137)	10.8 (274)

Footnotes:

(1) These listed speeds are a mechanical limitation. The maximum speed of a positioning table depends on the screw diameter, screw lead, screw length, and the screw end bearing support configuration. *LINTECH* uses a fixed-simple screw end bearing support configuration in its positioning tables. The correct motor & drive system needs to be selected in order to obtain the above maximum table speeds.

Screws - Acme & Ball

SCREW	ROLLED BALL SCREWS							
	Dyn. ⁽¹⁾ Capacity	Static Capacity	Screw Efficiency	Breakaway Torque	Position Accuracy	Backlash	Unidirectional Repeatability	Bidirectional Repeatability
	lbs (kg)	lbs (kg)	%	oz-in (N-m)	inch/ft (microns/300 mm)	inches (microns)	inches (microns)	inches (microns)
0.625 inch dia. 0.200 inch lead	<i>Non-preloaded</i> (S005)	800 (363)	6,150 (2790)	90	10 (0,07)	< 0.003 (75)	< 0.008 (203)	+ 0.0002 to - 0.0082 (5) (208)
	<i>Preloaded</i> (S006)	720 (326)	6,070 (2753)		20 (0,14)		0	+ 0.0002 to - 0.0002 (5) (5)
	<i>Non-preloaded</i> Turcite Nut (S007)	100 (45)	800 (363)	60	15 (0,11)	< 0.008 (203)	+ 0.0002 to - 0.0082 (5) (208)	
	<i>Preloaded</i> Turcite Nut (S008)	90 (41)	800 (363)		30 (0,21)	0	+ 0.0002 to - 0.0002 (5) (5)	
0.625 inch dia. 1.000 inch lead	<i>Non-preloaded</i> (S009)	590 (267)	2,425 (1100)	90	25 (0,18)	< 0.004 (100)	< 0.008 (203)	+ 0.0002 to - 0.0082 (5) (208)
	<i>Preloaded</i> (S010)	530 (240)	2,390 (1084)		40 (0,28)		0	+ 0.0002 to - 0.0002 (5) (5)
	<i>Non-preloaded</i> Turcite Nut (S011)	100 (45)	800 (363)	60	35 (0,25)	< 0.008 (203)	+ 0.0002 to - 0.0082 (5) (208)	
	<i>Preloaded</i> Turcite Nut (S012)	90 (41)	800 (363)		60 (0,42)	0	+ 0.0002 to - 0.0002 (5) (5)	
0.750 inch dia. 0.200 inch lead	<i>Non-preloaded</i> (S013)	1,900 (862)	18,800 (8527)	90	20 (0,14)	< 0.003 (75)	< 0.008 (203)	+ 0.0002 to - 0.0082 (5) (208)
	⁽²⁾ <i>Preloaded</i> (S014)	1,710 (776)	18,610 (8441)		30 (0,21)		0	+ 0.0002 to - 0.0002 (5) (5)
	<i>Non-preloaded</i> Turcite Nut (S015)	195 (88)	1,500 (680)	60	25 (0,18)	< 0.008 (203)	+ 0.0002 to - 0.0082 (5) (208)	
	<i>Preloaded</i> Turcite Nut (S016)	175 (79)	1,500 (680)		40 (0,28)	0	+ 0.0002 to - 0.0002 (5) (5)	
0.750 inch dia. 0.5000 inch lead	<i>Non-preloaded</i> (S017)	3,450 (1565)	24,200 (10977)	90	25 (0,18)	< 0.003 (75)	< 0.008 (203)	+ 0.0002 to - 0.0082 (5) (208)
	⁽²⁾ <i>Preloaded</i> (S018)	3,150 (1429)	23,855 (10820)		40 (0,28)		0	+ 0.0002 to - 0.0002 (5) (5)
	<i>Non-preloaded</i> Turcite Nut (S019)	195 (88)	1,500 (680)	60	35 (0,25)	< 0.008 (203)	+ 0.0002 to - 0.0082 (5) (208)	
	<i>Preloaded</i> Turcite Nut (S020)	175 (79)	1,500 (680)		60 (0,42)	0	+ 0.0002 to - 0.0002 (5) (5)	

Footnotes:

- (1) Dynamic load capacity of screw based on 1 million inches of travel (25Km).
- (2) There is a 0.8 inch (20,3 mm) reduction of carriage travel (from the listed travel) when using a preloaded nut with this screw option for all the 90-WC0 (6 inch carriage) model versions. All the 12 inch carriage model numbers and the 90-WC1 series are not affected.

Screws - Acme & Ball

SCREW	ROLLED BALL SCREWS							
	Dyn. ⁽¹⁾ Capacity	Static Capacity	Screw Efficiency	Breakaway Torque	Position Accuracy	Backlash	Unidirectional Repeatability	Bidirectional Repeatability
	lbs (kg)	lbs (kg)	%	oz-in (N-m)	inch/ft (microns/300 mm)	inches (microns)	inches (microns)	inches (microns)
1.000 inch dia. 0.250 inch lead	<i>Non-preloaded</i> (S021)	3,350 (1519)	30,750 (13947)	90	25 (0,18)	< 0.009 (229)		+ 0.0002 to - 0.0092 (5) (234)
	⁽²⁾ <i>Preloaded</i> (S022)	3,015 (1367)	30,415 (13796)		40 (0,28)			0
	<i>Non-preloaded</i> Turcite Nut (S023)	195 (88)	1,500 (680)	60	35 (0,25)	< 0.009 (229)		+ 0.0002 to - 0.0092 (5) (234)
	<i>Preloaded</i> Turcite Nut (S024)	175 (79)	1,500 (680)		60 (0,42)	0		+ 0.0002 to - 0.0002 (5) (5)
1.000 inch dia. 0.5000 inch lead	<i>Non-preloaded</i> (S025)	3,950 (1791)	32,300 (14650)	90	30 (0,21)	< 0.009 (229)		+ 0.0002 to - 0.0092 (5) (234)
	⁽²⁾ <i>Preloaded</i> (S026)	3,555 (1612)	31,905 (14471)		50 (0,35)			0
	<i>Non-preloaded</i> Turcite Nut (S027)	195 (88)	1,500 (680)	60	45 (0,32)	< 0.009 (229)		+ 0.0002 to - 0.0092 (5) (234)
	<i>Preloaded</i> Turcite Nut (S028)	175 (79)	1,500 (680)		80 (0,56)	0		+ 0.0002 to - 0.0002 (5) (5)
1.000 inch dia. 1.000 inch lead	<i>Non-preloaded</i> (S029)	2,250 (1020)	13,750 (6236)	90	35 (0,25)	< 0.009 (229)		+ 0.0002 to - 0.0092 (5) (234)
	⁽²⁾ <i>Preloaded</i> (S030)	2,025 (918)	13,525 (6134)		60 (0,42)			0
	<i>Non-preloaded</i> Turcite Nut (S031)	195 (88)	1,500 (680)	60	50 (0,35)	< 0.009 (229)		+ 0.0002 to - 0.0092 (5) (234)
	<i>Preloaded</i> Turcite Nut (S032)	175 (79)	1,500 (680)		90 (0,64)	0		+ 0.0002 to - 0.0002 (5) (5)

Footnotes:

- (1) Dynamic load capacity of screw based on 1 million inches of travel (25Km).
- (2) There is a 1.3 inch (33,0 mm) reduction of carriage travel (from the listed travel) when using a preloaded nut with this screw option for all the 90-WC0 (6 inch carriage) model versions. All the 12 inch carriage model numbers and the 90-WC1 series are not affected.

Screws - Acme & Ball

SCREW	PRECISION BALL SCREWS								
	Dyn. ⁽¹⁾ Capacity	Static Capacity	Screw Efficiency	Breakaway Torque	Position Accuracy	Backlash	Unidirectional Repeatability	Bidirectional Repeatability	
	lbs (kg)	lbs (kg)	%	oz-in (N-m)	inch/ft (microns/300 mm)	inches (microns)	inches (microns)	inches (microns)	
0.625 inch dia. 0.200 inch lead	<i>Non-preloaded</i> (S114)	876 (397)	2,700 (1224)	90	10 (0,07)	< 0.002 (50)	< 0.003 (76)	+/- 0.0002 (5)	+ 0.0002 to - 0.0032 (5) (81)
	<i>Preloaded</i> (S115)	788 (357)	2,430 (1102)		20 (0,14)		0		+ 0.0002 to - 0.0002 (5) (5)
16 mm dia. 5 mm lead	<i>Non-preloaded</i> (S116)	876 (397)	2,700 (1224)	90	10 (0,07)	< 0.002 (50)	< 0.003 (76)	+/- 0.0002 (5)	+ 0.0002 to - 0.0032 (5) (81)
	<i>Preloaded</i> (S117)	788 (357)	2,430 (1102)		20 (0,14)		0		+ 0.0002 to - 0.0002 (5) (5)
16 mm dia. 10 mm lead	<i>Non-preloaded</i> (S118)	1,080 (489)	2,630 (1192)	90	15 (0,11)	< 0.002 (50)	< 0.003 (76)	+/- 0.0002 (5)	+ 0.0002 to - 0.0032 (5) (81)
	<i>Preloaded</i> (S119)	972 (440)	2,365 (1072)		25 (0,18)		0		+ 0.0002 to - 0.0002 (5) (5)
16 mm dia. 16 mm lead	<i>Non-preloaded</i> (S120)	819 (371)	1,620 (734)	90	20 (0,14)	< 0.002 (50)	< 0.003 (76)	+/- 0.0002 (5)	+ 0.0002 to - 0.0032 (5) (81)
	<i>Preloaded</i> (S121)	737 (334)	1,455 (659)		35 (0,24)		0		+ 0.0002 to - 0.0002 (5) (5)
0.750 inch dia. 0.200 inch lead	<i>Non-preloaded</i> (S122)	964 (437)	3,360 (1524)	90	15 (0,11)	< 0.002 (50)	< 0.003 (76)	+/- 0.0002 (5)	+ 0.0002 to - 0.0032 (5) (81)
	<i>Preloaded</i> (S123)	867 (393)	3,025 (1372)		25 (0,18)		0		+ 0.0002 to - 0.0002 (5) (5)
20 mm dia. 5 mm lead	<i>Non-preloaded</i> (S124)	1,070 (485)	3,990 (1809)	90	15 (0,11)	< 0.002 (50)	< 0.003 (76)	+/- 0.0002 (5)	+ 0.0002 to - 0.0032 (5) (81)
	<i>Preloaded</i> (S125)	960 (435)	3,590 (1628)		25 (0,18)		0		+ 0.0002 to - 0.0002 (5) (5)
20 mm dia. 20 mm lead	<i>Non-preloaded</i> (S128)	1,293 (586)	3,505 (1589)	90	25 (0,18)	< 0.002 (50)	< 0.003 (76)	+/- 0.0002 (5)	+ 0.0002 to - 0.0032 (5) (81)
	⁽⁴⁾ <i>Preloaded</i> (S129)	1,160 (526)	3,150 (1428)		40 (0,28)		0		+ 0.0002 to - 0.0002 (5) (5)

Footnotes:

(1) Dynamic load capacity of screw based on 1 million inches of travel (25Km).

Screws - Acme & Ball

SCREW	GROUND BALL SCREWS ⁽²⁾							
	Dyn. ⁽¹⁾ Capacity lbs (kg)	Static Capacity lbs (kg)	Screw Efficiency %	Breakaway Torque oz-in (N-m)	Position Accuracy inch/ft (microns/300 mm)	Backlash inches (microns)	Unidirectional Repeatability inches (microns)	Bidirectional Repeatability inches (microns)
0.625 dia., 0.200 lead ⁽²⁾ Preloaded (S212)	987 (447)	3,080 (1397)	90	20 (0,14)	< 0.002 (50)	0	+/- 0.0002 (5)	+ 0.0002 to - 0.0002 (5)
0.625 dia., 0.500 lead ⁽²⁾ Preloaded (S213)	1430 (649)	4,191 (1901)	90	30 (0,21)	< 0.002 (50)	0	+/- 0.0002 (5)	+ 0.0002 to - 0.0002 (5)
16 mm dia., 5 mm lead ⁽²⁾ Preloaded (S214)	987 (447)	3,080 (1397)	90	20 (0,14)	< 0.002 (50)	0	+/- 0.0002 (5)	+ 0.0002 to - 0.0002 (5)
16 mm dia., 16 mm lead ⁽²⁾ Preloaded (S215)	910 (412)	1,800 (816)	90	35 (0,24)	< 0.002 (50)	0	+/- 0.0002 (5)	+ 0.0002 to - 0.0002 (5)

Footnotes:

(1) Dynamic load capacity of screw based on 1 million inches of travel (25Km).

(2) The 0.625 inch & 16 mm diameter Ground Ball Screw options are only available in travel lengths where the screw length is less than 47 inches (1194 mm).

Screws - Acme & Ball

SCREW	ROLLED ACME SCREWS								
	Dyn. ⁽¹⁾ Capacity	Static Capacity	Screw Efficiency	Breakaway Torque	Position Accuracy	Backlash	Unidirectional Repeatability	Bidirectional Repeatability	
	lbs (kg)	lbs (kg)	%	oz-in (N-m)	inch/ft (microns/300 mm)	inches (microns)	inches (microns)	inches (microns)	
0.625 inch dia. 0.100 inch lead	<i>Non-preloaded</i> (S300)	160 (73)	800 (363)	40	10 (0,07)	< 0.003 (75)	< 0.008 (203)	+/- 0.0002 (5)	+ 0.0002 to - 0.0082 (5) (208)
	<i>Preloaded</i> (S301)	140 (64)	720 (327)		20 (0,14)		0		+ 0.0002 to - 0.0002 (5) (5)
0.625 inch dia. 0.200 inch lead	<i>Non-preloaded</i> (S302)	160 (73)	800 (363)	40	15 (0,11)	< 0.003 (75)	< 0.008 (203)	+/- 0.0002 (5)	+ 0.0002 to - 0.0082 (5) (208)
	<i>Preloaded</i> (S303)	140 (64)	720 (327)		30 (0,21)		0		+ 0.0002 to - 0.0002 (5) (5)

Footnotes:

(1) Dynamic load capacity of screw based on 1 million inches of travel (25Km).

Motor Couplings

LINTECH provides three different types of couplings that can be used to mount a motor to a positioning table. These couplings compensate for misalignment between the motor shaft & screw shaft extension. This provides for trouble-free operation as long as certain precautions are taken. The connected motor output torque should never exceed the coupling maximum torque capacity. Larger capacity couplings may be required for applications having high accelerations, large back driving loads, high torque output motors, or servo motors.

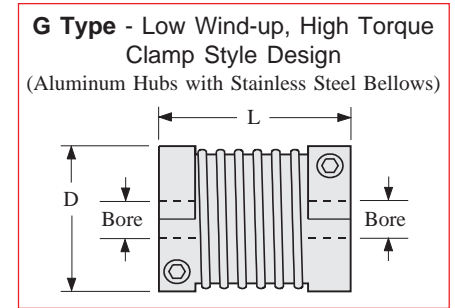
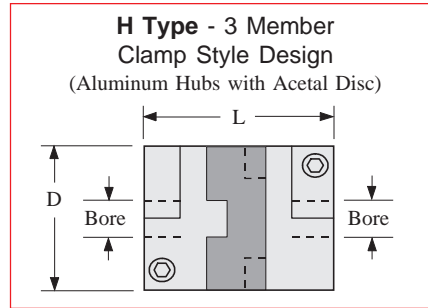
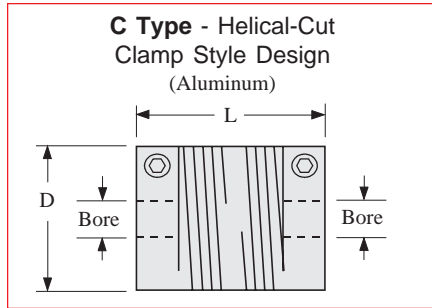

Model # (1)	D inches (mm)	L inches (mm)	Bore Diameters				Weight ounces (grams)	Inertia oz-in ² (g-cm ²)	Wind-up arc-sec/oz-in (deg/N-m)	Max Torque oz-in (N-m)
			Table	Motor	Minimum (in) (mm)	Maximum (in) (mm)				
C100-375-aaa	1.00 (25,4)	1.50 (38,1)	375	aaa	.250 6	.375 10	1.5 (43)	.19 (35)	23.0 (0,9)	400 (2,8)
C125-375-aaa	1.25 (31,8)	2.00 (50,8)	375	aaa	.250 6	.500 14	3.5 (99)	.68 (124)	15.0 (0,59)	700 (4,9)
H100-375-aaa	1.00 (25,4)	1.28 (32,5)	375	aaa	.250 6	.375 10	1.2 (34)	.15 (27)	7.2 (0,28)	450 (2,8)
H131-375-aaa	1.31 (33,3)	1.89 (48,0)	375	aaa	.250 6	.625 16	2.9 (82)	.62 (114)	2.5 (0,098)	1,000 (7,1)
G100-375-aaa	0.99 (25,2)	1.26 (32,0)	375	aaa	.250 6	.500 12	1.3 (36)	.16 (29)	1.0 (0,39)	500 (3,5)
G126-375-aaa	1.26 (32,1)	1.62 (41,0)	375	aaa	.250 6	.625 16	2.7 (74)	.54 (99)	0.3 (0,012)	1,100 (7,7)
Possible values for aaa	250 = .250 inch 375 = .375 inch 500 = .500 inch 625 = .625 inch				005 = 5 mm 006 = 6 mm 008 = 8 mm 010 = 10 mm	012 = 12 mm 014 = 14 mm 016 = 16 mm				

Footnotes:

- (1) See page D-27 for maximum coupling diameter and length specifications for use with the optional NEMA 23 & 34 motor mounts. Custom motor mounts can be provided upon request.

Motor Couplings

Coupling	Cost	Torque Capacity	Wind-up	Suggested Motor	Comments
C Type	least expensive	light	the most	stepper	ideal for most step motor applications
H Type	medium priced	medium	medium	stepper or servo	use for high accels & for starting & stopping large inertia loads
G Type	most expensive	high	the least	servo	use for very high torque requirements & very high servo accelerations

Specification	90 Series	90 Series
	NEMA 23 bracket	NEMA 34 bracket
	inches (mm)	inches (mm)
Shaft extension diameter at motor mount end	0.375 (9,53)	0.375 (9,53)
Maximum coupling diameter	1.500 (38,10)	1.500 (38,10)
Maximum coupling length	2.100 (53,34)	2.600 (66,04)
Note: Custom brackets available upon request.		

Coupling Part Numbers

C025 C100-375-250	C130 H100-375-250	C407 G100-375-250
C026 C100-375-375	C131 H100-375-375	C408 G100-375-375
C027 C100-375-006	C132 H100-375-006	C409 G100-375-500
C028 C100-375-008	C133 H100-375-008	C410 G100-375-006
C029 C100-375-010	C134 H100-375-010	C411 G100-375-008
		C412 G100-375-010
		C413 G100-375-012
C048 C125-375-250	C155 H131-375-250	
C049 C125-375-375	C156 H131-375-375	
C050 C125-375-500	C157 H131-375-500	C435 G126-375-250
C051 C125-375-006	C158 H131-375-625	C436 G126-375-375
C052 C125-375-008	C159 H131-375-006	C437 G126-375-500
C053 C125-375-010	C160 H131-375-008	C438 G126-375-625
C054 C125-375-012	C161 H131-375-010	C439 G126-375-006
C055 C125-375-014	C162 H131-375-012	C440 G126-375-008
	C163 H131-375-014	C441 G126-375-010
	C164 H131-375-016	C442 G126-375-012
		C443 G126-375-014
		C444 G126-375-016

NEMA 34 Motor Mount

The NEMA 34 motor adapter bracket is an aluminum flange that mounts to the front of the NEMA 23 motor mount. The bracket can be ordered in either an English, or Metric motor mount. *LINTECH* can provide adapter brackets for any step motor, or servo motor, that has other mounting requirements.

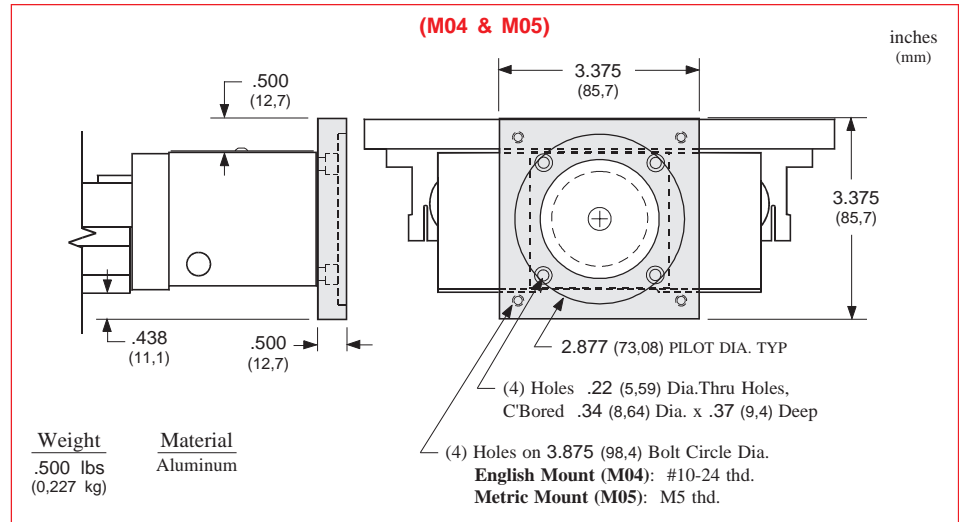

Hand Crank

For manually operated applications, *LINTECH* provides a hand crank option for the 90 table series. The hand crank replaces the motor mount and coupling on the table.

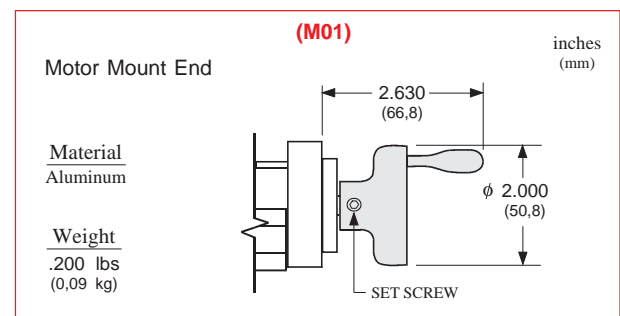

Chrome Plated Linear Bearings, Rails, and Screws

For applications in high moisture, high humidity, clean room, or highly corrosive environments, chrome plating of the linear bearings, linear rails, and screw will offer superior resistance to corrosion than stainless steel components, resulting in longer table life. The process uniformly deposits dense, hard, high chromium alloy on the rails or screw, and has a Rockwell C hardness value of 67-72. This process also conforms to MIL Spec: (MIL-C-23422). The chrome plating bonds to the parent material and will not crack or peel off under the high point loading of balls on the rail, or screw. This chrome plating process differs from a normal hard chrome plate which just lays on the surface of the part plated.

Motor Wrap Packages

For space limited 90 series applications, a belt and pulley system can couple the screw shaft extension to the motor shaft. This wraps the motor parallel to the table in order to decrease the overall positioning system length. Pulley weights and diameters are given in order to assist in calculating motor torque requirements.

NEMA 23 Right Hand Motor Wrap (M06)

0.7 lbs (0,32 kg) added to table weight inches (mm)
Motor Pulley Bore: 0.250 inch (6,35 mm)

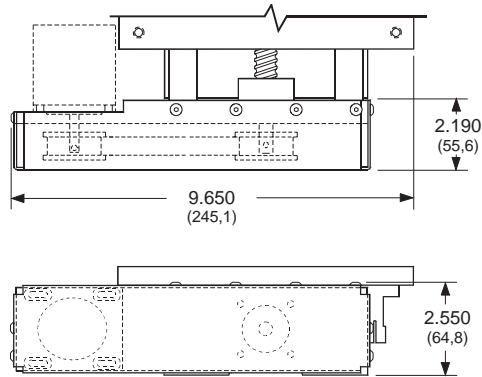

NEMA 34 Right Hand Motor Wrap (M08)

1.1 lbs (0,50 kg) added to table weight inches (mm)
Motor Pulley Bore: 0.375 inch (9,52 mm)

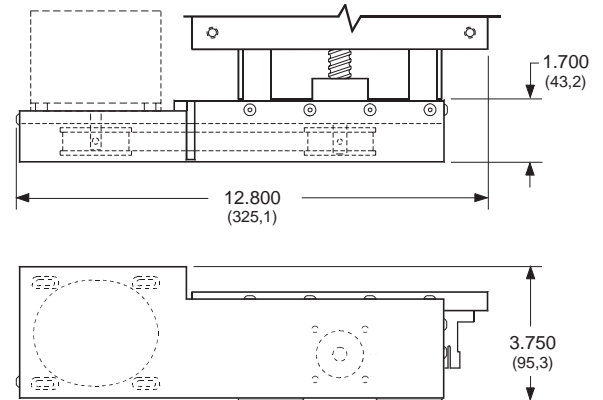

NEMA 42 Right Hand Motor Wrap (M12)

1.9 lbs (0,86 kg) added to table weight inches (mm)
Motor Pulley Bore: 0.625 inch (15,87 mm)

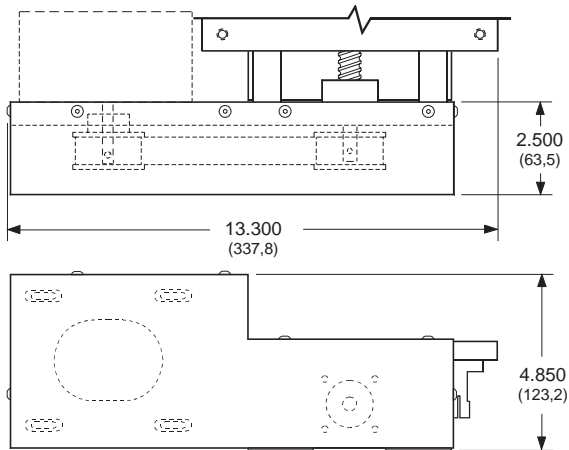

Note: Right hand motor wraps shown. The left hand wrap packages orient the motor to the opposite side of the table. Motor pulley & belt shipped "loose". No motor mount nuts & bolts are provided. Custom motor wrap packages are available upon request. Other motor pulley bores MUST be specified for non-NEMA motors.

Motor Wrap Frame Size	Motor Pulley Dia. inches (mm)	Motor Pulley Wt. ounces (kg)	Screw Pulley Dia. inches (mm)	Screw Pulley Wt. ounces (kg)	Belt Weight ounces (kg)
NEMA 23	1.65 (41,9)	7.5 (0,21)	1.65 (41,9)	7.5 (0,21)	1.0 (0,028)
NEMA 34	1.65 (41,9)	8.0 (0,23)	1.65 (41,9)	8.0 (0,23)	1.2 (0,034)
NEMA 42	2.12 (53,9)	19.2 (0,54)	2.12 (53,9)	19.2 (0,54)	3.0 (0,085)

Power-off Electric Brakes

For vertical table applications, or for those applications requiring the load to be locked securely in place, an electric brake may be mounted to the positioning table. The 90 series will have the brake mounted to the screw shaft extension located on the table end, opposite the motor mount bracket. With proper wiring from a control system, this power-off friction brake can ensure that the carriage is firmly held in place, when no electric power is applied to the brake. When power is applied to the brake, the brake is opened or "released".

For proper emergency braking of the positioning table, this electric brake needs to be interfaced to a position controller or relay network. *LINTECH* also provides 24 & 90 VDC power supplies which can be used to power the brakes.

Brakes

Model Number	Holding Force		Excitation Voltage	Current	Weight
	in-lbs (N-m)				
B01	18 (2,0)		24 VDC	0.733	1.4 (0,62)
B02	18 (2,0)		90 VDC	0.178	1.4 (0,62)

Note: This power-off electric brake MUST NOT be engaged when the positioning table is in motion. Moving the table with the brake applied could damage the brake and the positioning table. Also, continuous use of this brake to stop a table (load) that is in motion could damage the brake and the positioning table. Dynamic braking of a positioning table should be done by the motor and not the brake.

Power Supplies

Model Number	DC Output			AC Input		
	volts	amps	style	volts	amps	Hz
41970	5	3.0	regulated	120 / 240	0.8 / 0.4	47-63
37488	24	1.2	regulated	120 / 240	0.8 / 0.4	47-63
37489	90	0.8	unregulated	120	1.0	50/60
37490	90	0.8	unregulated	240	0.5	50/60

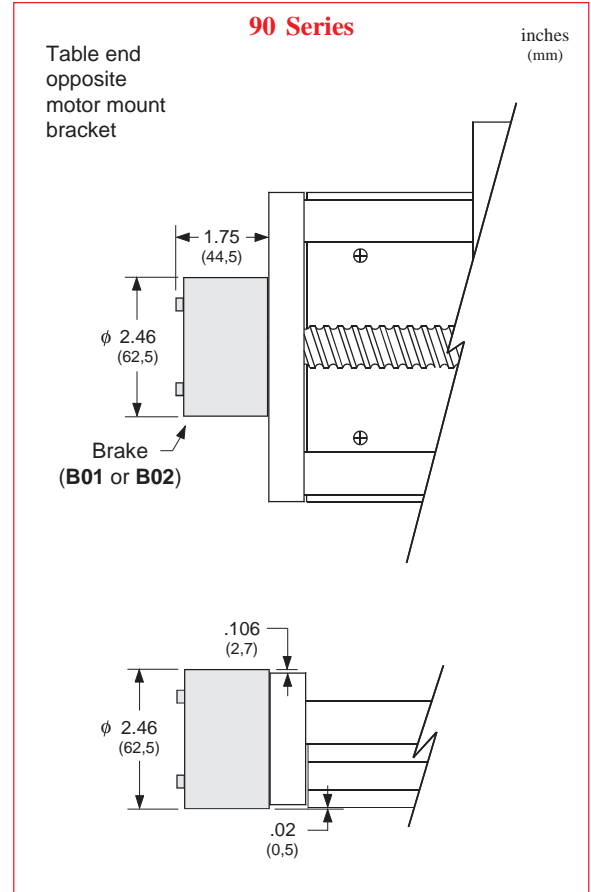

Linear & Rotary Incremental Encoders

Fully enclosed, incremental, optical linear encoders can be mounted along side any *LINTECH* 90 series table. Shaftless, incremental, optical rotary encoders can be mounted to the screw shaft extension opposite the motor mount end on the 90 series positioning tables. These encoders provide positional feedback to either a motion controller, or a digital position display.

LINEAR		ROTARY	Description
Din Pin #	Wire Color	Wire Color	
C	Green	White	Channel A+ (or A)
D	Yellow	Blue	Channel A- (or \bar{A})
E	Pink	Green	Channel B+ (or B)
L	Red	Orange	Channel B- (or \bar{B})
G	Brown	White/Black	Channel Z+ (or Z)
H	Grey	Red/Black	Channel Z- (or \bar{Z})
A	Shield		Case ground
B	White	Black	Common
K	Black	Red	+ 5 vdc (+/- 5%)

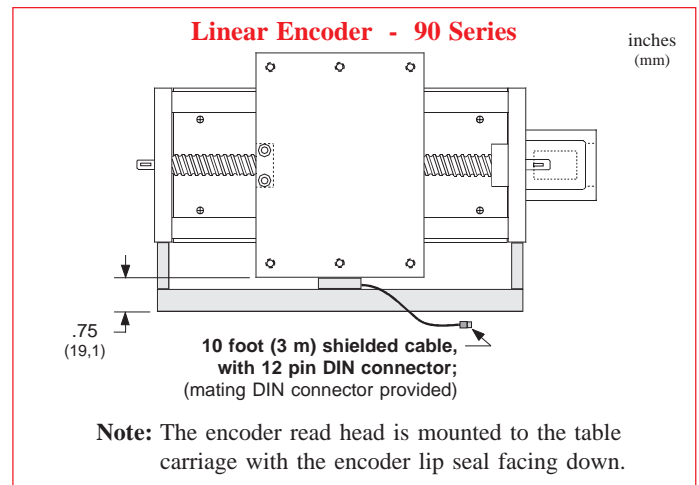
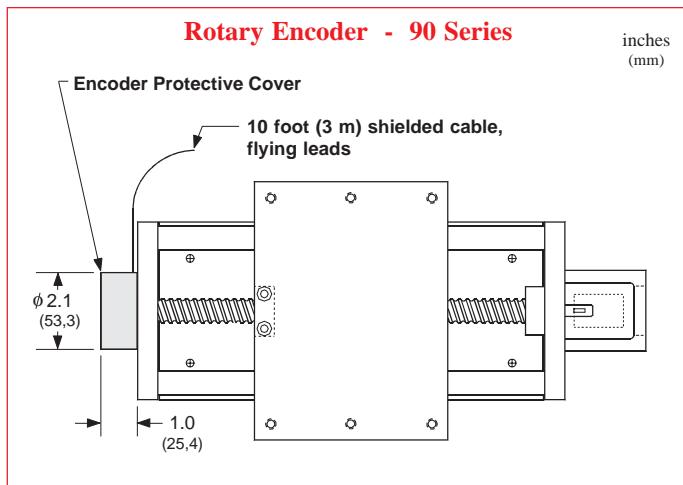

Specification	ROTARY ENCODERS			LINEAR ENCODERS	
	E01	E02	E03	E10	E11
Line Count	500 lines/rev	1000 lines/rev	1270 lines/rev	2500 lines/inch	125 lines/mm
Pre Quadrature Resolution	0.002 revs/pulse	0.001 revs/pulse	0.00079 revs/pulse	0.0004 inch/pulse	8 microns/pulse
Post Quadrature Resolution	0.0005 revs/pulse	0.00025 revs/pulse	0.00019 revs/pulse	0.0001 inch/pulse	2 micron/pulse
Accuracy				+/- 0.0002 in/40"	+/- 5 microns/m
Maximum Speed	50 revs/sec			79 inches/sec	2 m/sec
Maximum Accel	40 revs/sec ²			130 ft/sec ²	40 m/sec ²
Excitation Power	+ 5 VDC @ 125 ma			+ 5 VDC @ 150 ma	
Operating Temperature	32 ^o F to 140 ^o F (0 ^o C to 60 ^o C)			32 ^o F to 120 ^o F (0 ^o C to 50 ^o C)	
Humidity	20% to 80% non condensing			20% to 80% non condensing	
Shock	10 G's for 11 msec duration			15 G's for 8 msec duration	
Weight	0.7 lbs (0,283 kg)			0.7 oz/inch (0,00078 kg/mm) length of scale + 0.5 lbs (0,23 kg) read head and brackets	
Cable Length	10 ft (3 m), unterminated 26 gauge leads			10 ft (3 m) with DIN connector	
Zero Reference Output	Once per revolution			At center of encoder length	
Outputs	TTL square wave; Two channel (A+ & B+); Differential (A- & B-); Line Driver				

Specifications subject to change without notice

