

550 Series Positioning Tables



Introduction	K-2
Ordering Guide	K-4
Specifications	K-5
Dimensions	K-6
Table Deflection	K-9
Linear Bearing Load Capacity	K-10
Thrust Capacity	K-11
Carriage Adapter Plates	K-12
Horizontal Adapter Brackets	K-15
Vertical Adapter Brackets	K-16
Gearheads	K-20
Motor Mount Options	K-22
EOT & Home Switches	K-23
Motor Couplings	K-26
Power-off Electric Brakes	K-28
Rotary Encoders	K-29

Single or Multiple Axis

LINTECH's 550 series positioning tables offer precision performance and design flexibility for use in a wide variety of Motion Control applications.

- ❑ *Welding*
- ❑ *Test Stands*
- ❑ *Part Insertion*
- ❑ *Laser Positioning*
- ❑ *Liquid Dispensing*
- ❑ *Semiconductor Processing*
- ❑ *Gluing*
- ❑ *Pick & Place*
- ❑ *Part Scanning*
- ❑ *Inspection Stations*
- ❑ *General Automation*

Quality Construction

LINTECH's 550 series tables are designed to handle large loads at very high speeds. These tables use a low friction, preloaded, recirculating linear ball bearing system, which rides on a single precision ground linear rail. The single linear rail is mounted to a precision machined aluminum base, which offers a rigid support over the entire travel of the table's carriage. The load is mounted to a precision machined aluminum carriage, which has slots machined into it. These slots, along with the base mounting brackets, are used for the mounting of the user load. The drive system uses two pulleys, along with a high strength, steel reinforced polyurethane belt, which provides 8.071 inches (205 mm) of linear movement per revolution of the input shaft. The simple belt tensioning system allows for easy adjustment of belt tension by the user. The belt also acts as a cover, preventing debris from getting into the linear bearings & rail.

The 553 carriage uses 2 high load capacity linear bearings on one precision ground square rail. Both bearings are connected to an internal lubrication network. Any of the 4 lube ports, located on the carriage surface, can be used to supply lubrication to the 2 linear bearings.

The 554 carriage uses 2 high load capacity linear bearings on one precision ground square rail. Both bearings are out-fitted with a self-lubricating material which eliminates the need for regular lubrication. No lube ports are provided on the carriage surface.

The 555 carriage uses 2 high load capacity linear bearings on one precision ground square rail. A unique ball retainer design for the recirculating linear bearings provides a smoother operating system with less audible noise. Both bearings are connected to an internal lubrication network. Any of the 4 lube ports, located on the carriage surface, can be used to supply lubrication to the 2 linear bearings.

Available Options

Carriage Adapter Plates & Vertical Angle Brackets

Optional carriage adapter plates and vertical angle brackets can be mounted directly to the top of various *LINTECH* positioning tables, thus providing for easy multiple axis configurations.

End of Travel and Home Switches

The 550 series tables can be provided with end of travel (EOT) and home switches mounted and wired for each axis. Most position controllers can utilize the EOT switches to stop carriage motion when the extreme table travel has been reached in either direction. The home switch provides a known mechanical location on the table.

Motor Adapter Brackets

NEMA 34, NEMA 42, or any metric mount motor can be mounted to a 550 series positioning table with the use of adapter brackets.

Rotary Encoders

Incremental rotary encoders can be mounted to the table in order to provide positional data back to either a motion controller, or a digital display.

Planetary Gearheads

LINTECH provides planetary gearheads which can be used with a 550 series. These gearheads are provided in either an in-line or right angle version, with standard gear ratios of 1:1, 3:1, 5:1 or 10:1. Gearheads may be required for applications which have a large mismatch of load to motor inertias. They also help reduce the torque required from the motor for a particular application.

Other

The 550 series tables can accommodate **chrome plated linear bearings & rails** for corrosive environment applications and **power-off electric brakes** for load locking applications.

Standard Features - 550 Series

- ❑ 10.236 inches (260 mm) long carriage with two M5 slots for load mounting
- ❑ Compact 3.15 inches (80 mm) wide by 3.937 inches (100 mm) tall
- ❑ Travel lengths from 12 inches (300 mm) to 30 feet (9,1 meters)
- ❑ Rigid belt driven design with fully enclosed aluminum housing
- ❑ 0° F to +176° F (-18° C to +80° C) operating temperature
- ❑ Two screw belt tensioning with self locking threads
- ❑ Dynamic Load Capacity to 10,500 lbs (4763 kg)
- ❑ Recirculating linear ball bearing system
- ❑ Precision ground square rail design
- ❑ 1 rail with 2 bearing carriages

550 Series (553 Carriage)



- ❑ Two bearing carriage
- ❑ 10,500 lbs (4763 kg) dynamic load capacity
- ❑ 410 ft-lbs (556 N-m) dynamic roll moment
- ❑ Less expensive than the 555 carriage
- ❑ Large moment load capability

550 Series (554 Carriage)



- ❑ Two bearing carriage
- ❑ 10,500 lbs (4763 kg) dynamic load capacity
- ❑ 410 ft-lbs (556 N-m) dynamic roll moment
- ❑ Self lubricating linear bearings
- ❑ Large moment load capability

550 Series (555 Carriage)



- ❑ Two bearing carriage
- ❑ 9,120 lbs (4136 kg) dynamic load capacity
- ❑ 172 ft-lbs (233 N-m) dynamic roll moment
- ❑ Less audible noise than the 553 or 554 series
- ❑ Smoother than the 553 or 554 carriage
- ❑ Unique linear bearing design

Options - 550 Series

- ❑ Angle brackets for multiple axis configurations
- ❑ End of travel (EOT) and home switches wired
- ❑ AUTOCAD® drawings available upon request
- ❑ Chrome plated linear bearings and rails
- ❑ Motor mounts for non-NEMA motors
- ❑ NEMA 34 & 42 motor mounts
- ❑ Rotary incremental encoders
- ❑ Power-off electric brakes
- ❑ Base mounting brackets
- ❑ Carriage adapter plates
- ❑ Planetary gearheads
- ❑ Motor couplings

K

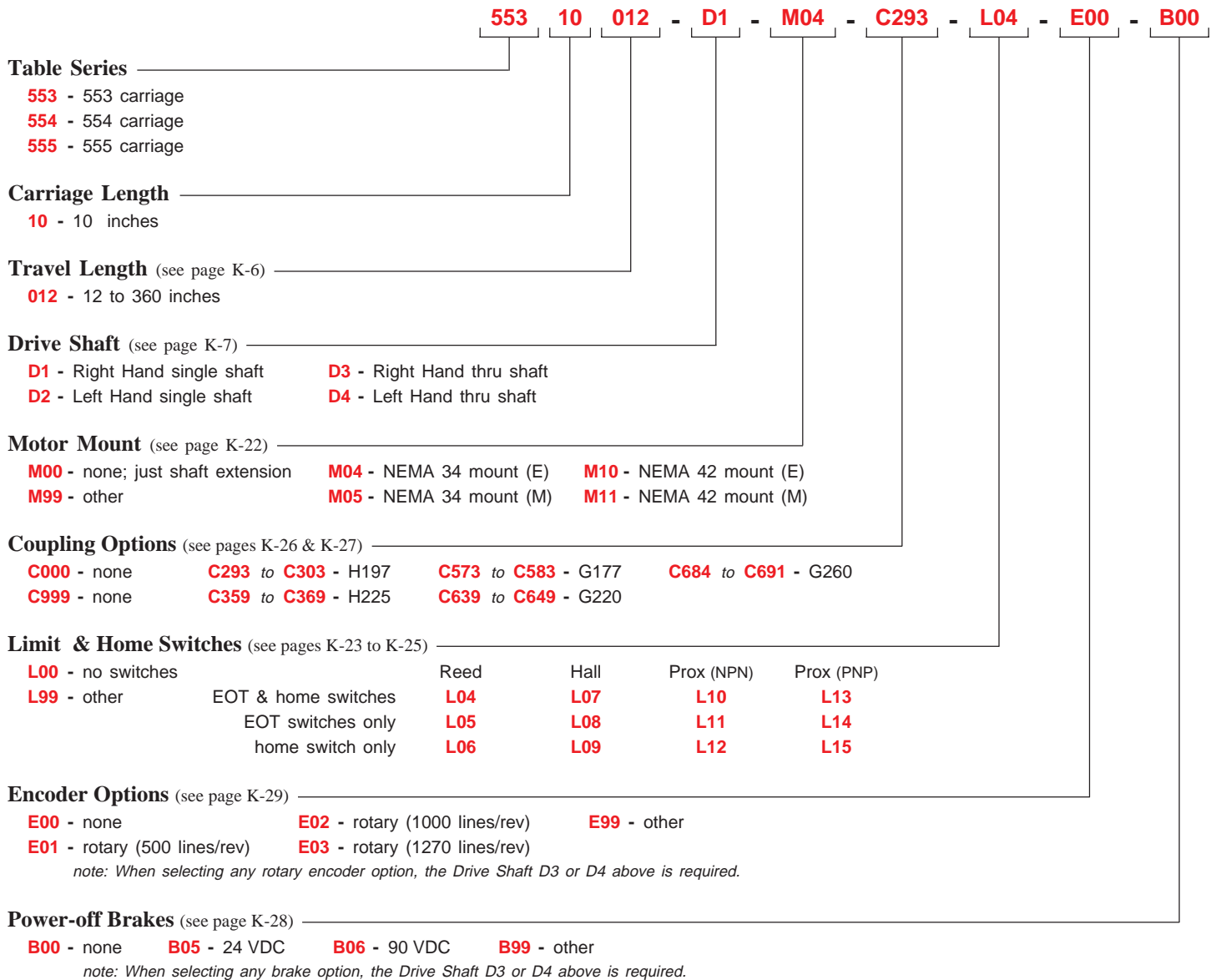

(E) - English Interface
(M) - Metric Interface

Specifications

Made in the U.S.A.

Load Capacities		553 & 554 Carriages		555 Carriage	
Dynamic Horizontal	2 million inches (50 km) of travel	10,500 lbs	(4763 kg)	9,120 lbs	(4136 kg) ⁽¹⁾
Dynamic Horizontal	50 million inches (1270 km) of travel	3,590 lbs	(1628 kg)	3,119 lbs	(1414 kg) ⁽¹⁾
Static Horizontal		15,400 lbs	(6985 kg)	14,700 lbs	(6668 kg) ⁽¹⁾
Dynamic Roll Moment	2 million inches (50 km) of travel	410 ft-lbs	(556 N-m)	172 ft-lbs	(233 N-m)
Dynamic Roll Moment	50 million inches (1270 km) of travel	140 ft-lbs	(190 N-m)	59 ft-lbs	(80 N-m)
Static Roll Moment		650 ft-lbs	(881 N-m)	285 ft-lbs	(386 N-m)
Dyn. Pitch & Yaw Moment	2 million inches (50 km) of travel	1,215 ft-lbs	(1647 N-m)	510 ft-lbs	(690 N-m)
Dyn. Pitch & Yaw Moment	50 million inches (1270 km) of travel	414 ft-lbs	(561 N-m)	174 ft-lbs	(236 N-m)
Static Pitch & Yaw Moment		1,775 ft-lbs	(2406 N-m)	845 ft-lbs	(1145 N-m)
Each Bearing Dyn. Capacity	2 million inches (50 km) of travel	5,250 lbs	(2381 kg)	4,560 lbs	(2068 kg) ⁽¹⁾
Each Bearing Dyn. Capacity	50 million inches (1270 km) of travel	1,795 lbs	(814 kg)	1,559 lbs	(707 kg) ⁽¹⁾
Each Bearing Static Load Capacity		7,700 lbs	(3493 kg)	7,350 lbs	(3334 kg) ⁽¹⁾
Maximum Belt Tensile Force		675 lbs	(306 kg)	675 lbs	(306 kg)
Maximum Carriage Thrust Force		475 lbs	(215 kg)	475 lbs	(215 kg)
Maximum Speed		118 in/sec	(3 m/sec)	197 in/sec	(5 m/sec)
Maximum Acceleration		1,930 in/sec ²	(49,0 m/sec ²)	1,930 in/sec ²	(49,0 m/sec ²)
d₂	Center to center distance (spacing) of each bearing on a single rail	3.876 in	(98,4 mm)	3.876 in	(98,4 mm)
d_r	Center distance of the bearing to top of carriage plate surface	1.508 in	(38,3 mm)	1.626 in	(41,3 mm)

Other	553, 554 & 555 Carriages
Table Material	Base Extrusion, Carriage, & End Plates - 6061 anodized aluminum
Linear Rail Material	Case Hardened Steel
Belt Properties	Black, 50 mm wide, Polyurethane, Steel reinforced belt
Drive Pulley Weight	1.500 lbs (0,68 kg)
Drive Pulley Diameter	2.569 in (65,25 mm)
Drive Lead	8.071 in (205,00 mm)
Belt Stretch - x Load (lbs or N)	0.00006 in/ft per lbs (0,00114 mm/m per N)
Unidirectional Repeatability	+/- 0.001 in (+/- 0,0254 mm)
Bidirectional Repeatability	+/- 0.004 in (+/- 0,1016 mm)
Position Accuracy (Belt) ⁽²⁾	< 0.010 in/ft (< 0,254 mm/300mm)
Orthogonality (multi-axis systems)	< 60 arc-seconds
Friction Coefficient	< 0.01
Breakaway Torque ⁽³⁾	< 16 lb-in (1,808 N-m)
Motor Mount	NEMA 34 & 42 Mounts, Metric Mounts, and Gearheads
Coupling	Two (2) different styles available

Footnotes:

- (1) Derate value by 50 % when load is applied to the open end of the bearing (inverted configuration).
- (2) Position accuracy varies based on belt stretch. The given rating is based upon a carriage speed of 5 inches/sec (127 mm/sec) and a no load condition.
- (3) This is a nominal value. Breakaway torque will increase, or decrease, based on belt tension.

Dimensions & Specifications

Made in the U.S.A.

Model Number	Travel ⁽¹⁾ Length inches (mm)	Table Dimensions inches (mm)		Belt Weight lbs (kg)	Table Weight (553 & 554 Carriages) lbs (kg)	Table Weight (555 Carriage) lbs (kg)
		A	B			
55x10012	12 (300)	24.00 (609,6)	32.275 (819,8)	0.29 (0,13)	24.1 (10,9)	23.0 (10,4)
55x10018	18 (455)	30.00 (762,0)	38.275 (972,2)	0.40 (0,18)	27.3 (12,4)	26.0 (11,8)
55x10024	24 (605)	36.00 (914,4)	44.275 (1124,6)	0.51 (0,23)	30.6 (13,9)	29.2 (13,2)
55x10030	30 (760)	42.00 (1066,8)	50.275 (1277,0)	0.62 (0,28)	33.9 (15,4)	32.3 (14,7)
55x10036	36 (910)	48.00 (1219,2)	56.275 (1429,4)	0.72 (0,33)	37.2 (16,9)	35.5 (16,1)
55x10048	48 (1215)	60.00 (1524,0)	68.275 (1734,2)	0.94 (0,43)	43.8 (19,9)	41.8 (19,0)
55x10060	60 (1520)	72.00 (1828,8)	80.275 (2039,0)	1.15 (0,52)	50.3 (22,8)	48.0 (21,8)
55x10072	72 (1825)	84.00 (2133,6)	92.275 (2343,8)	1.37 (0,62)	56.9 (25,8)	54.3 (24,6)
55x10084	84 (2130)	96.00 (2438,4)	104.275 (2648,6)	1.58 (0,72)	63.5 (28,8)	60.6 (27,5)
55x10096	96 (2435)	108.00 (2743,2)	116.275 (2953,4)	1.80 (0,82)	70.1 (31,8)	66.9 (30,3)
55x10108	108 (2740)	120.00 (3048,0)	128.275 (3258,2)	2.01 (0,91)	76.7 (34,8)	73.2 (33,2)
55x10120	120 (3045)	132.00 (3352,8)	140.275 (3563,0)	2.23 (1,01)	83.2 (37,8)	79.4 (36,0)
55x10132	132 (3350)	144.00 (3657,6)	152.275 (3867,8)	2.44 (1,11)	89.8 (40,8)	85.7 (38,9)
55x10144	144 (3655)	156.00 (3962,4)	164.275 (4172,6)	2.66 (1,21)	96.4 (43,7)	92.0 (41,7)
55x10180	180 (4572)	192.00 (4876,8)	200.275 (5087,0)	3.30 (1,50)	116.1 (52,7)	110.8 (50,3)
55x10240	240 (6096)	252.00 (6400,8)	260.275 (6611,0)	4.38 (1,99)	149.0 (67,6)	142.2 (64,5)
55x10300	300 (7620)	312.00 (7924,8)	320.275 (8135,0)	5.45 (2,47)	181.9 (82,5)	173.6 (78,7)
55x10360	360 (9144)	372.00 (9448,8)	380.275 (9659,0)	6.52 (2,96)	214.8 (97,4)	204.9 (92,9)

- x = 3; 553 Carriage; Carriage weight = 7.98 lbs. (3,62 kg)
- x = 4; 554 Carriage; Carriage weight = 7.98 lbs. (3,62 kg)
- x = 5; 555 Carriage; Carriage weight = 7.14 lbs. (3,24 kg)

Footnotes:

(1) Longest possible travel is 30 feet (9,1 meters). Any travel length less than 30 feet (9,1 meters) can be provided.

Specifications subject to change without notice

Dimensions

Made in the U.S.A.

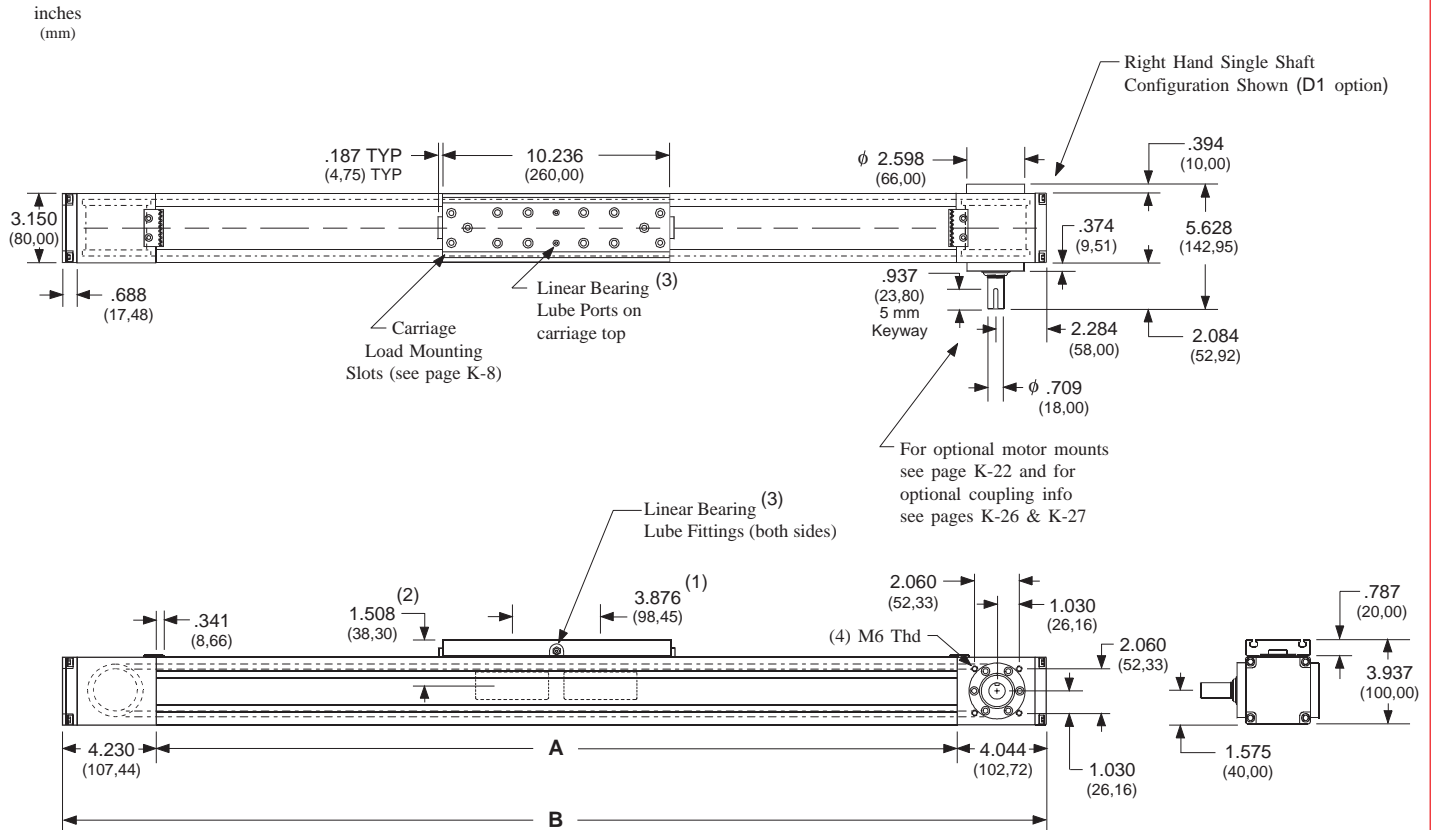

Thru Shaft Option

(D3 & D4) (D3 shown)

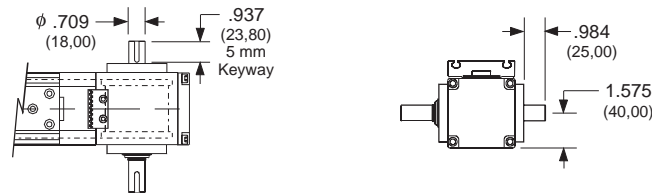

Footnotes:

- (1) This value is center to center distance (spacing) of each bearing on a single rail (d_c).
- (2) This value is the center distance of the bearing to top of carriage plate surface (d_t) for the 553 & 554 carriages. For the 555 carriage $d_t = 1.626$ inches (41,3 mm).
- (3) Two lube ports on carriage top and lube fittings on each side of the 553 & 555 carriages are all interconnected. Only one port is required to lubricate both linear bearings. The 554 carriage will not have any lube ports.

K

Carriage Fastener Rail & Base Mounting Brackets

LINTECH provides the user with 2 vital optional accessories. The carriage fastener rails slide into the two slots on the 550 series carriage. These fastener rails give the user the ability to mount their load to the 550 series carriage. From 1 to 3 fastener rails can be used in each carriage slot. The base mounting brackets give the user the ability to mount the 550 series table to a mounting surface. These mounting brackets attach anywhere along the bottom T-slot's on both sides of the 550 series table.

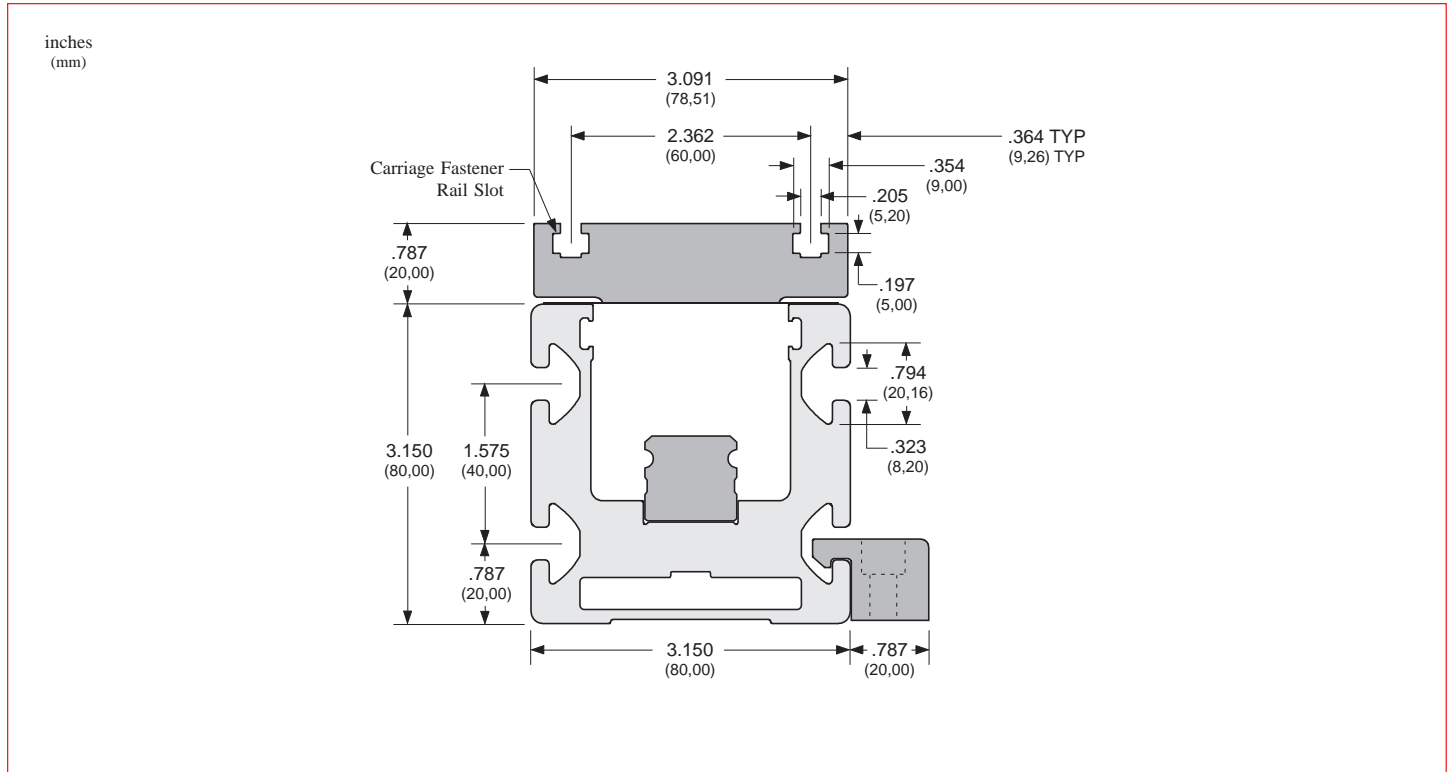

Carriage Fastener Rail
(part # 201174)

Material
Stainless Steel

Weight
.06 lbs
(0,027 kg)

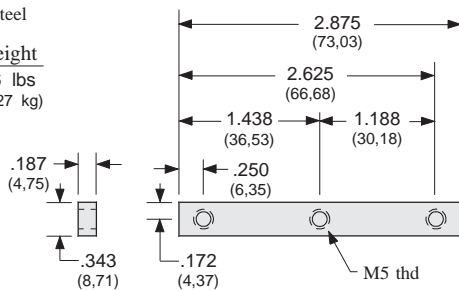

Base Mounting Brackets
(part # 46627)

Weight
.19 lbs
(0,086 kg)

Material
Aluminum

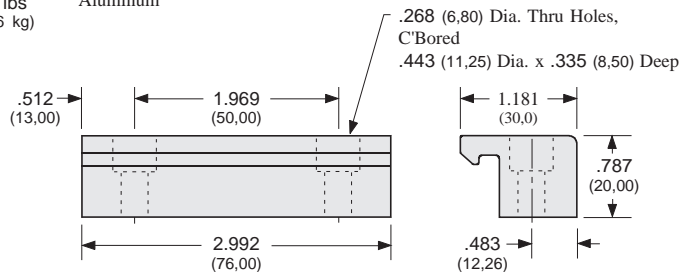
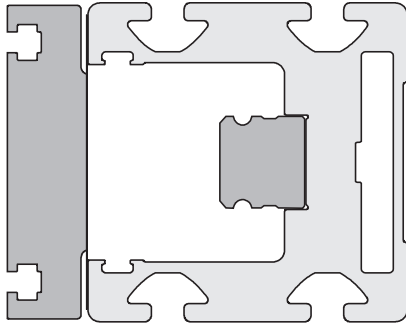

Table Deflection - Moment of Inertia Values

The "moment of inertia" of an object is a gauge of the strength of that object to resist deflecting when used in an application or orientation where deflection might occur. The higher an I value relates to a lower amount of deflection.

$$I = 3.10 \text{ in}^4 \text{ (} 1.29 \times 10^6 \text{ mm}^4\text{)}$$



$$I = 4.44 \text{ in}^4 \text{ (} 1.85 \times 10^6 \text{ mm}^4\text{)}$$

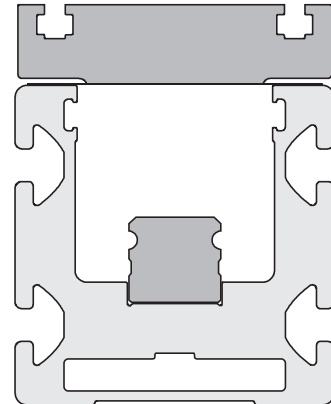

Linear Bearing Load Capacities

The following equation, and graphs, can be used to help determine the linear bearing life, and load capacity, of a 550 series positioning table.

$$L = \left[\frac{R}{F \times S} \right]^3 \times B$$

- L** = calculated travel life (millions of inches or Km)
- R** = rated dynamic load capacity of carriage (or each bearing) at 2 million inches of travel or 50 Km
- F** = user applied load
- S** = safety factor (1 to 8)
- B** = either 2 (for millions of inches) or 50 (for Km)

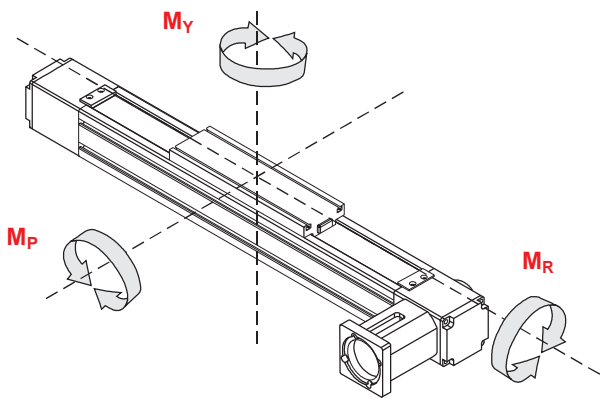

Dynamic Horizontal Load Capacity

Load Centered on Carriage

travel life		553 & 554 Carriage		555 Carriage	
millions of inches	(Km)	lbs	(kg)	lbs	(kg)
2	(50)	10,500	(4763)	9,120	(4136)
50	(1270)	3,590	(1628)	3,119	(1414)
100	(2540)	2,849	(1292)	2,475	(1123)

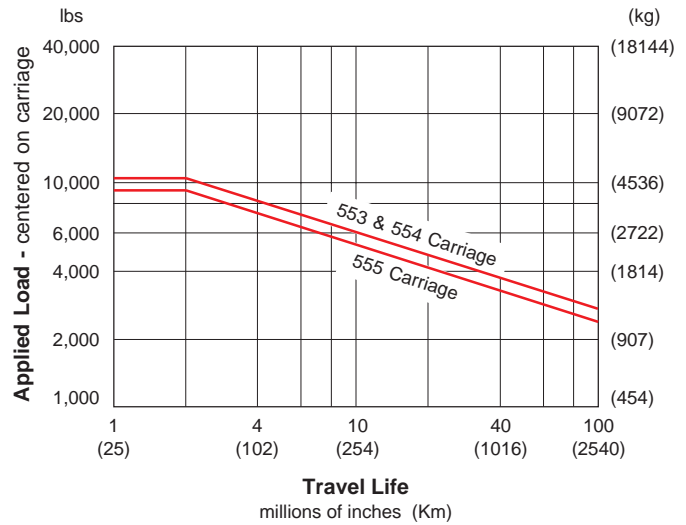

Dynamic Moment Load (M_R) Capacity

Load applied away from Carriage Center

travel life		553 & 554 Carriage		555 Carriage	
millions of inches	(Km)	ft-lbs	(N-m)	ft-lbs	(N-m)
2	(50)	410	(556)	172	(233)
50	(1270)	140	(190)	59	(80)
100	(2540)	111	(150)	47	(64)

Ratings are based on d₃ = 12 inches (305 mm) & d₄ = 0

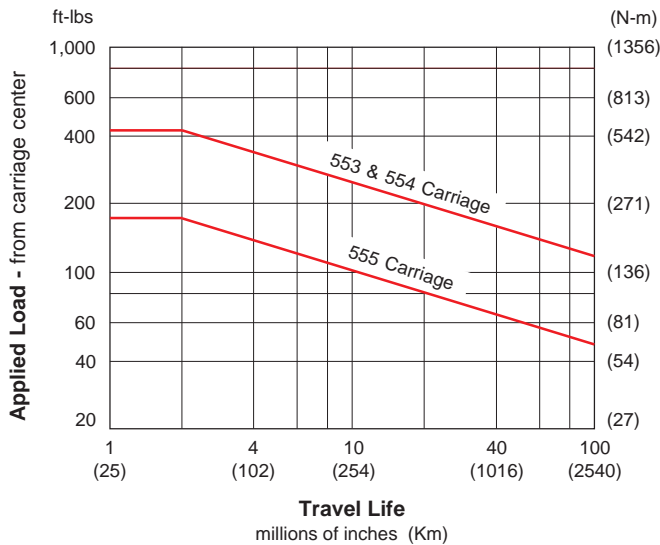

Dynamic Moment Load (M_P & M_Y) Capacity

Load applied away from Carriage Center

travel life		553 & 554 Carriage		555 Carriage	
millions of inches	(Km)	ft-lbs	(N-m)	ft-lbs	(N-m)
2	(50)	1,215	(1647)	510	(690)
50	(1270)	414	(561)	174	(236)
100	(2540)	330	(447)	138	(187)

Ratings are based on d₃ = 0 & d₄ = 12 inches (305 mm)

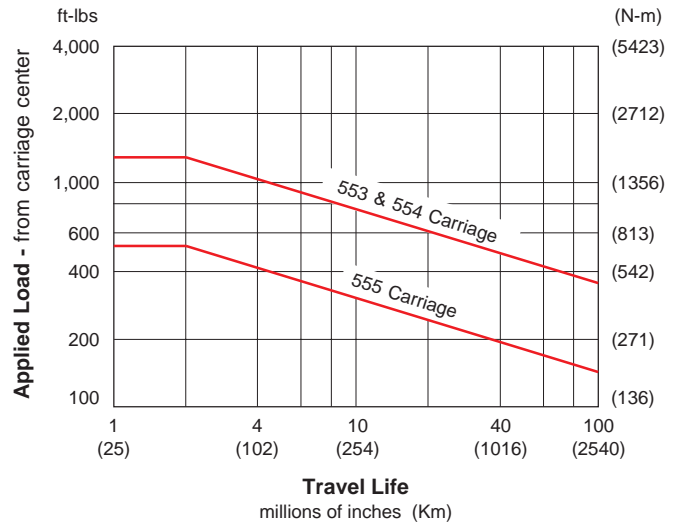

Maximum Motor Input Torque, Maximum Belt Force, & Maximum Acceleration Rate

Maximum Motor Input Torque

The maximum safe speed/torque of a motor/drive system that can be used with the 550 series, is limited by the belt strength at a given speed. The maximum linear forces the belt can adequately handle are determined by the number of teeth on the pulley and the belt width. The chart below illustrates the relationship between motor input torque/belt force and carriage speed. Care should be taken when sizing and selecting a motor/drive system for use with a 550 series table. Exceeding the maximum input torque values at the listed speeds can cause belt "skipping" over pulley teeth. This will result in mis-positioning of the carriage.

Maximum Acceleration

The maximum acceleration rate using a 550 series table can be determined by the simple equation $F = M \times A$. Knowing the mass of the load, and the maximum safe operating force for the belt, the maximum possible acceleration rate can be determined. **Note:** The mechanical limitation for acceleration of the 550 series table is 5 g's.

Maximum Acceleration Example

- F** = **M** x **A**
- F** = maximum belt force at desired speed
- M** = user applied load
- A** = maximum acceleration rate (g's)
- Sin ϕ** = angle of table from horizontal (degrees)

<u>Horizontal Application</u>	<u>Vertical Application</u>
$A = \frac{F}{M}$	$A = \frac{F - M \sin \phi}{M}$

Example: A 200 lb load is mounted to a 550 series carriage in a horizontal application. Determine the maximum accel rate in g's & in/sec² that can be used to achieve a maximum speed of 75 IPS.

- Step 1:** From graph below, determine the maximum belt force at 75 IPS : (**F = 235 lbs**).
- Step 2:** Add up your total mass = load weight + carriage weight : (**M = 5.4 + 200 = 205.4 lbs**).
- Step 3:** Solve for A : (**A = 235/205.4 = 1.1 g's**).
- Note:** 1 g = 386 in/sec²
- Step 5:** 1.1 g's x 386 = 424 in/sec².

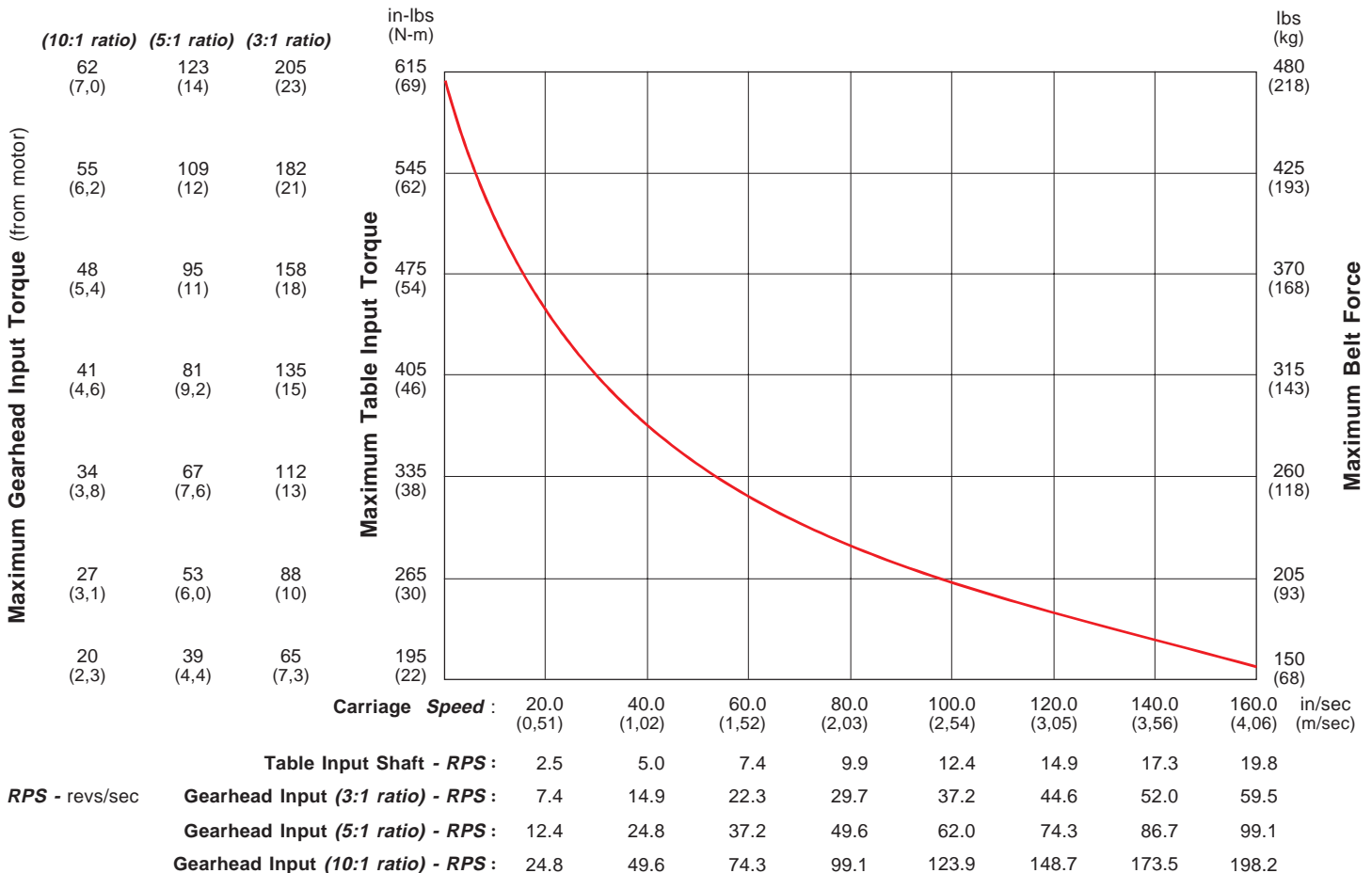

1) Table friction & breakaway forces have already been deducted from the above maximum belt force values.
 2) Curve based upon maximum belt values. Select a motor coupling that can handle the required torque.

Specifications subject to change without notice

Carriage Adapter Plate (550 Base to 550 Carriage)

Optional carriage adapter plates assist in the creation of simple X-Y, X-Z, and X-Y-Z multiple axis systems. Using one of the adapter plates below, allows a 550 series table to be mounted on top of a second 550 series table in order to make an X-Y axes system (see below). Also, using two of the adapter plates below, allows a 550 series table to be mounted on top of two 550 series tables in order to make an X-Y axes gantry system (see page K-14).

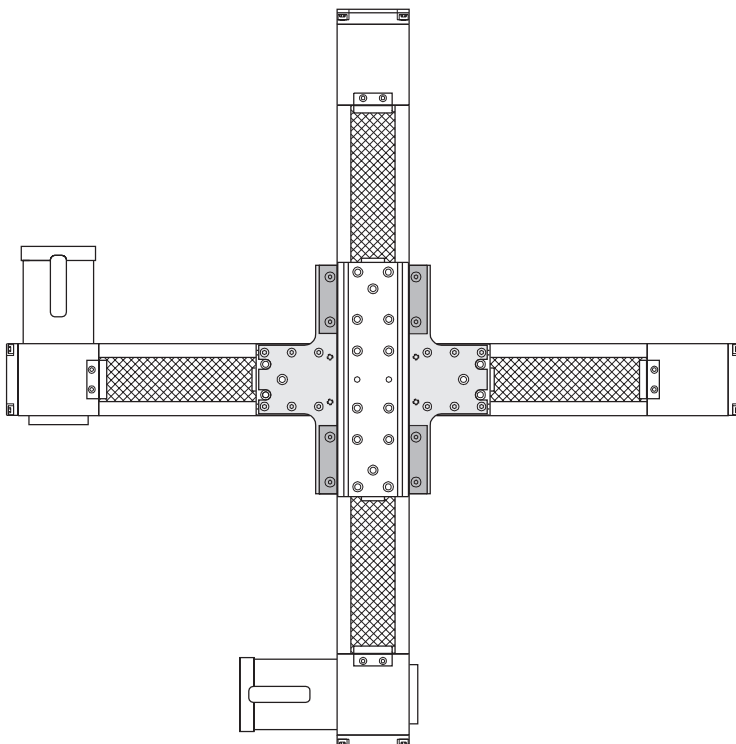
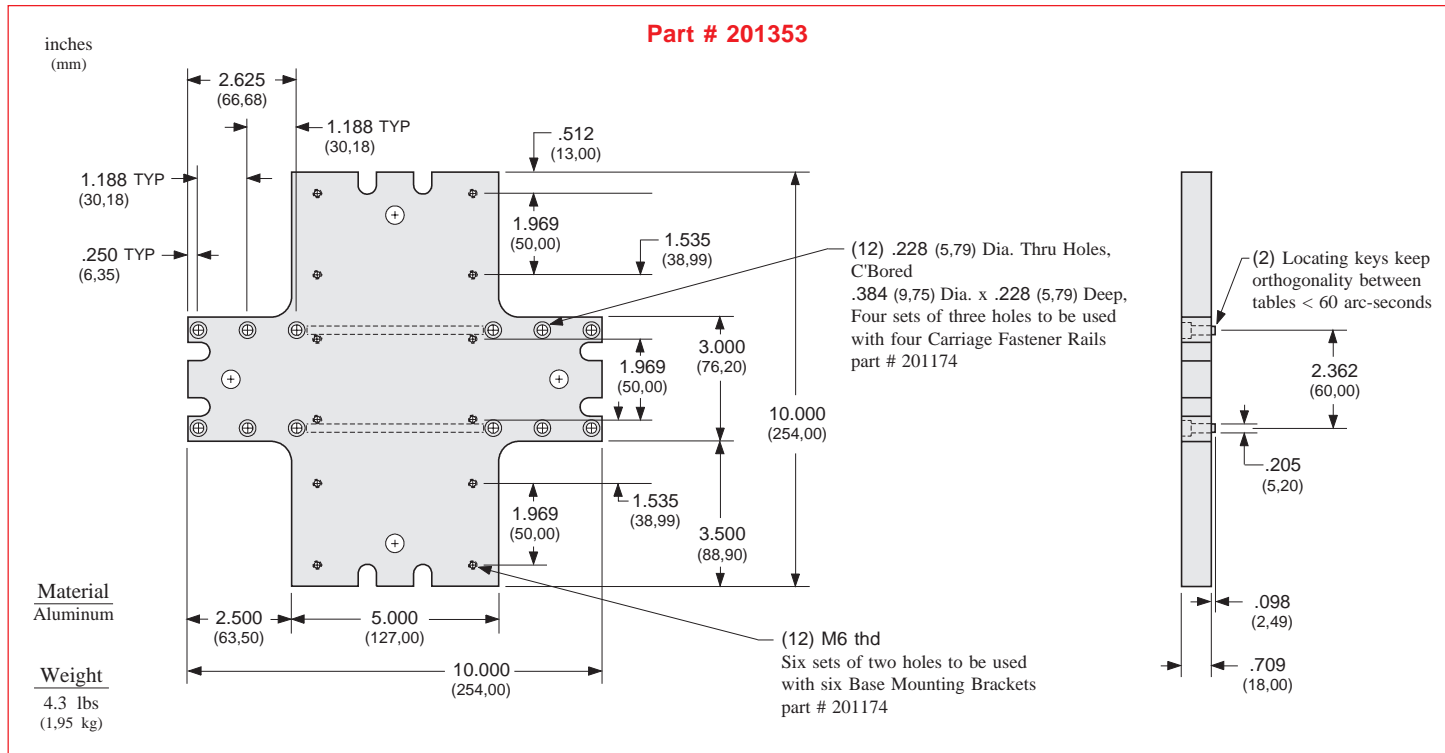

Mounting Hardware Kit Part # 202023

- a) 4 Carriage Fastener Rails
- b) 4 Base Mounting Brackets
- c) 12 M5 x 20 mm Bolts
- d) 8 M6 x 30 mm Bolts

Mounting Hardware Kit Part # 202024

- a) 4 Carriage Fastener Rails
- b) 6 Base Mounting Brackets
- c) 12 M5 x 20 mm Bolts
- d) 12 M6 x 30 mm Bolts

Carriage Adapter Plate (550 Carriage to 550 Carriage)

Optional carriage adapter plates assist in the creation of simple X-Y, X-Z, and X-Y-Z multiple axis systems. The adapter plate below allows two 550 series tables to be mounted carriage to carriage in order to make an X-Y axes system.

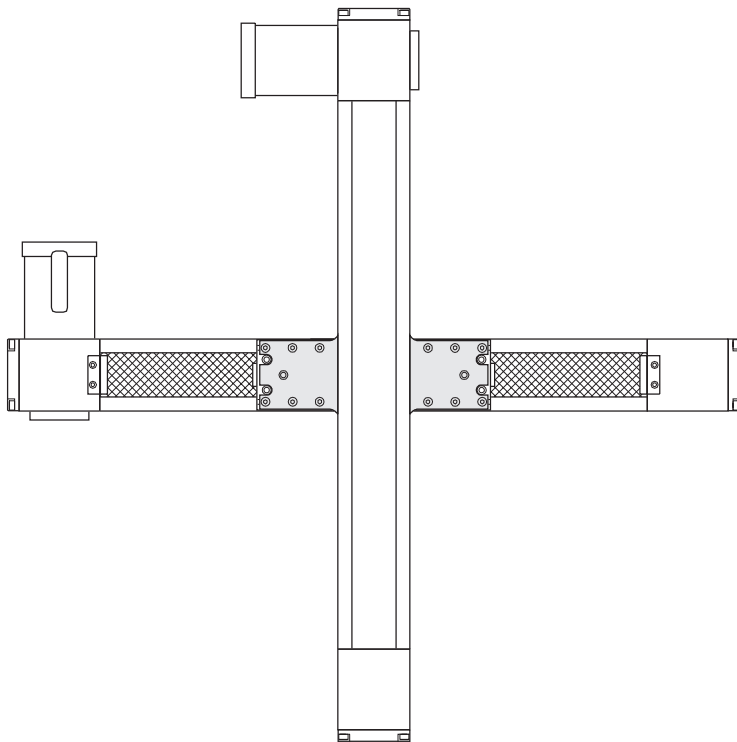
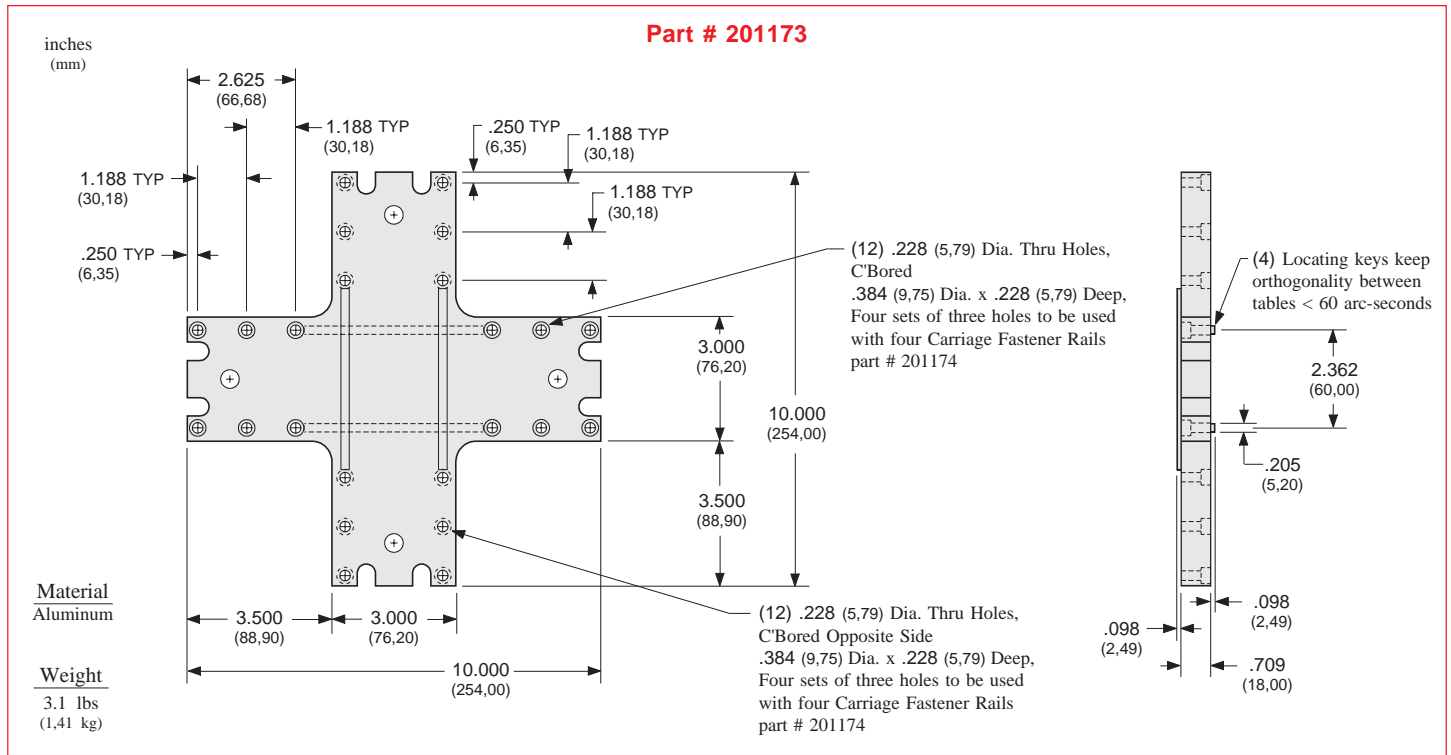

Mounting Hardware Kit Part # 202025

- 8 Carriage Fastener Rails
- 24 M5 x 20 mm Bolts

Carriage Adapter Plate (550 Base to 550 Carriage)

Optional carriage adapter plates assist in the creation of simple X-Y, X-Z, and X-Y-Z multiple axis systems. Using one of the adapter plates below, allows a 550 series table to be mounted on top of a second 550 series table in order to make an X-Y axes system (see page K-12). Also, using two of the adapter plates below, allows a 550 series table to be mounted on top of two 550 series tables in order to make an X-Y axes gantry system (see below).

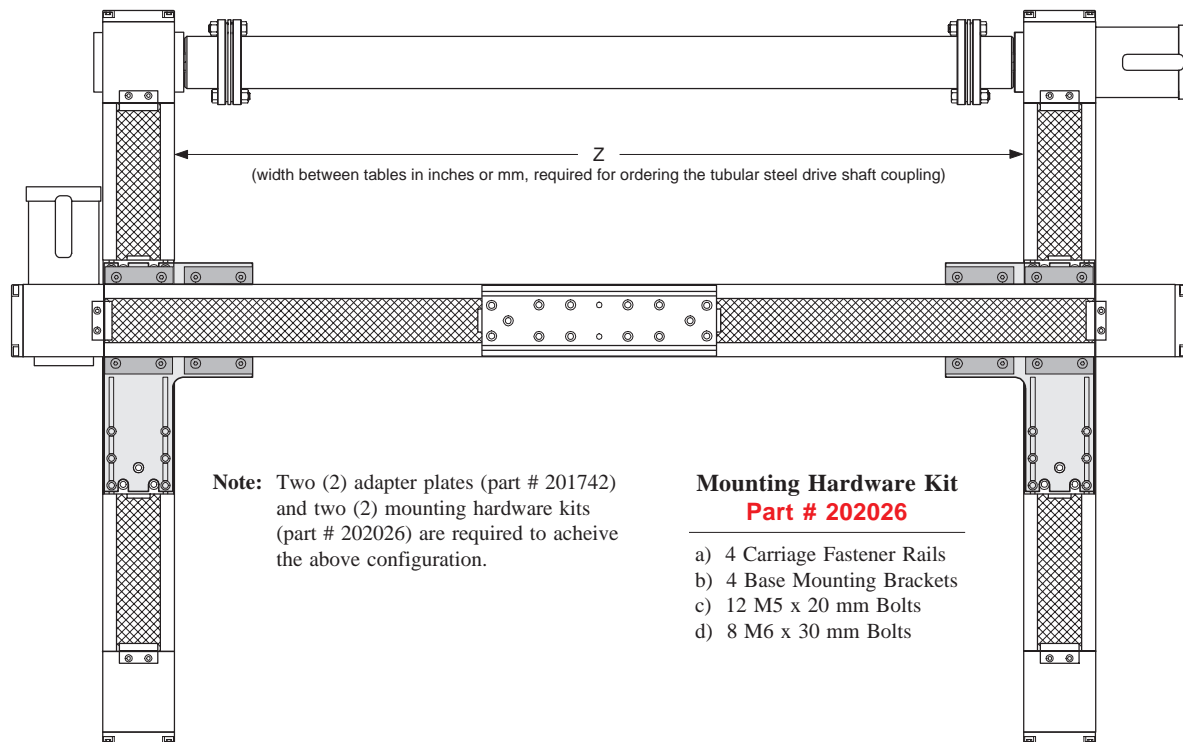
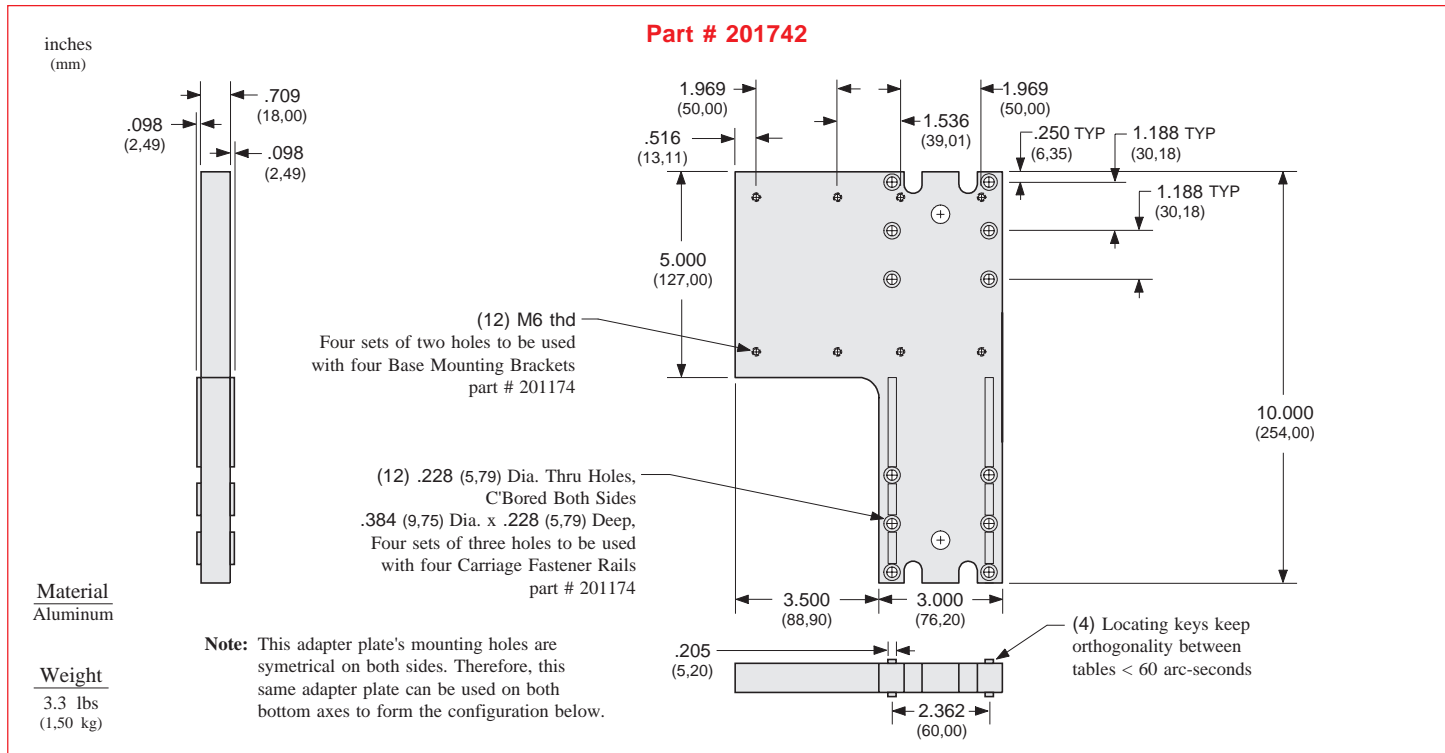

Horizontal Adapter Bracket (550 Series Base to 550 Carriage)

Optional horizontal adapter brackets assist in the creation of simple X-Y, X-Z, and X-Y-Z multiple axis systems. Using one of the adapter plates below, allows a 550 series table to be mounted on top of a second 550 series table in order to make an X-Y axes system. Also, using two of the adapter plates below, allows a 550 series table to be mounted on top of two 550 series tables in order to make an X-Y axes gantry system (see below).

Part # 201171

inches
(mm)

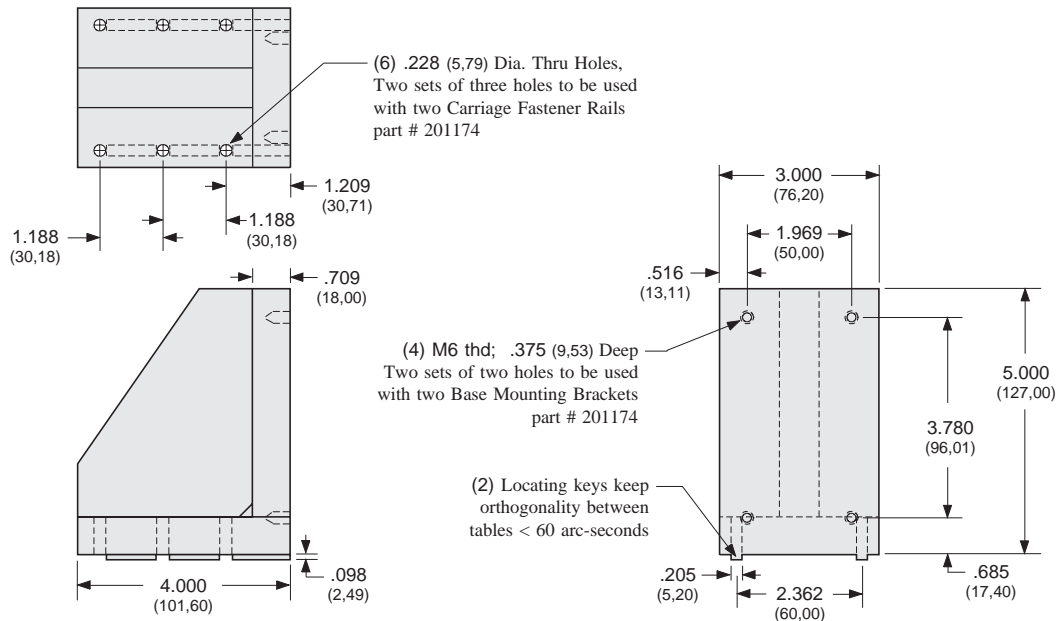

Material
Aluminum

Weight
2.7 lbs
(1.22 kg)

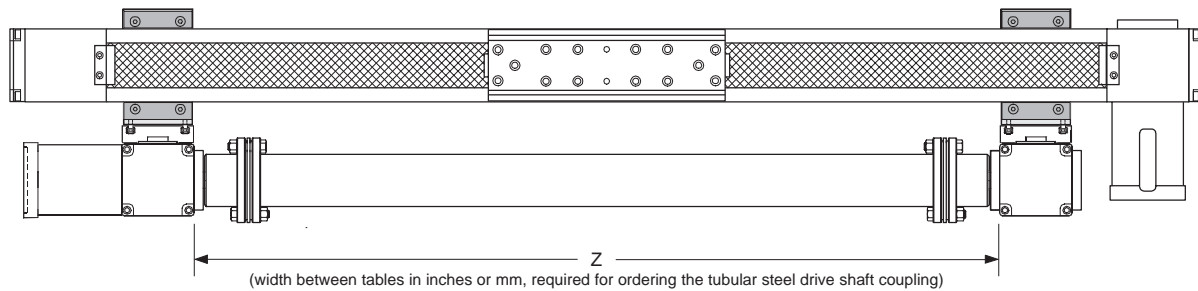

Tubular Steel Drive Shaft Coupling

- Material - Steel
- Torsional Stiffness - 62,690 ft-lbs/rad (85,000 M-m/rad)
- Bore both sides - 18 mm with 5 mm keyway
- Maximum Length - 118 inches (3 meters)
- Maximum Speeds:

Length (Z)		Max Speed
(inches)	(mm)	(rpm)
20	500	3000
40	1000	3000
60	1500	2600
80	2000	1450
100	2500	950
118	3000	650

Note: Two (2) adapter plates (part # 201171) and two (2) mounting hardware kits (part # 202027) are required to achieve the above configuration.

**Mounting Hardware Kit
Part # 202027**

- a) 2 Carriage Fastener Rails
- b) 2 Base Mounting Brackets
- c) 6 M5 x 20 mm Bolts
- d) 4 M6 x 30 mm Bolts

K

Vertical Adapter Bracket (550 Base to 550 Carriage)

Optional vertical adapter brackets assist in the creation of simple X-Y, X-Z, and X-Y-Z multiple axis systems. The vertical adapter bracket below allows a 550 series table to be mounted on top of a second 550 series table in order to make an X-Z axes system.

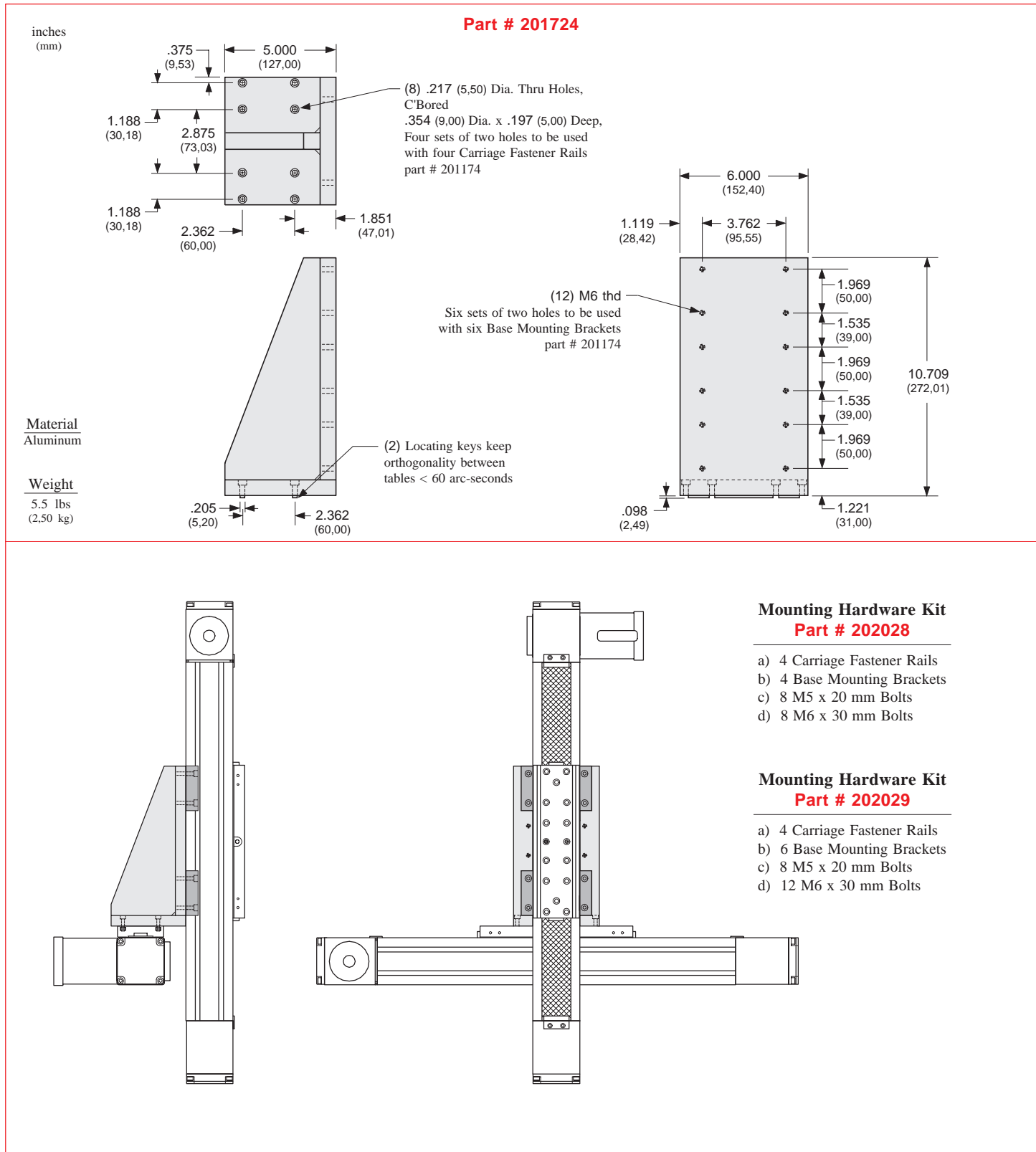

Vertical Adapter Bracket (550 Carriage to 550 Carriage)

Optional vertical adapter brackets assist in the creation of simple X-Y, X-Z, and X-Y-Z multiple axis systems. The vertical adapter bracket below allows two 550 series tables to be mounted carriage to carriage in order to make an X-Z axes system.

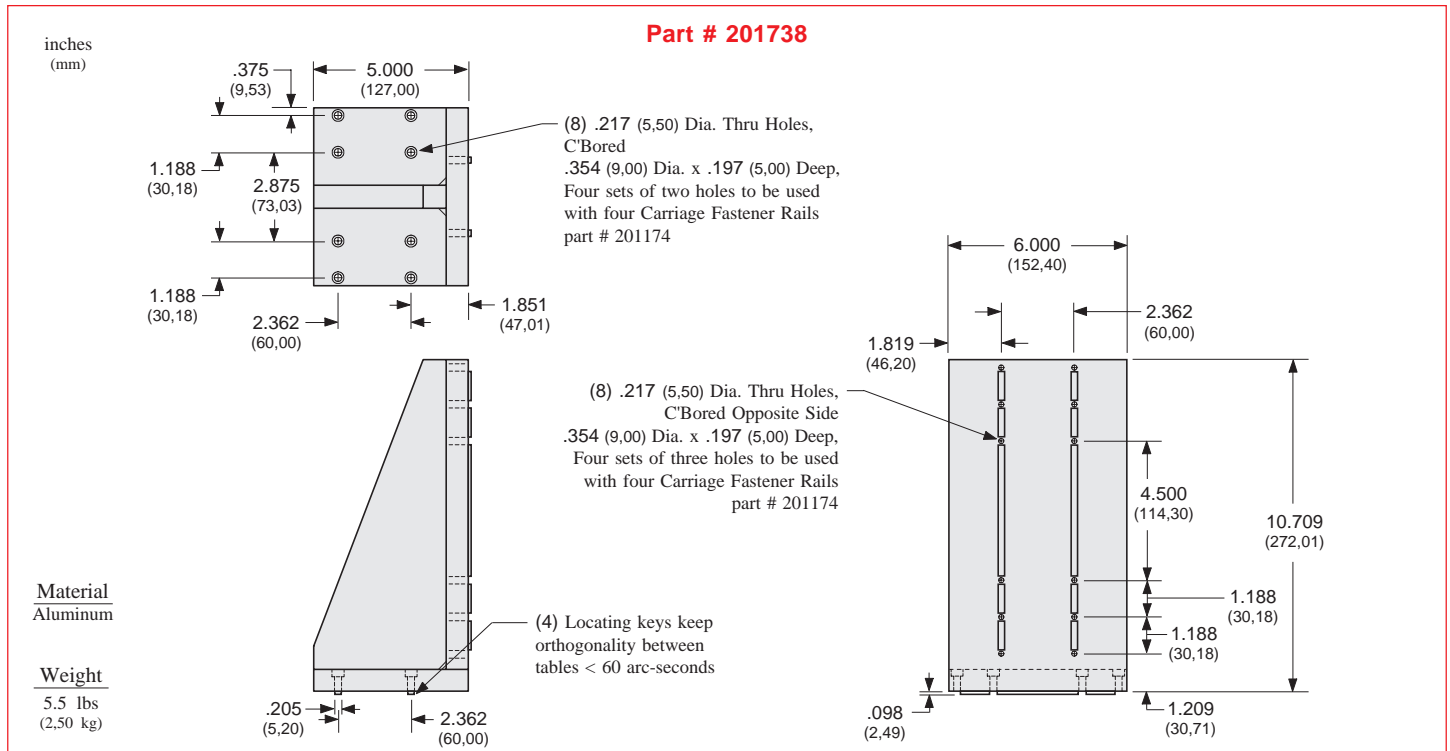

**Mounting Hardware Kit
Part # 202030**

- a) 8 Carriage Fastener Rails
- b) 20 M5 x 20 mm Bolts

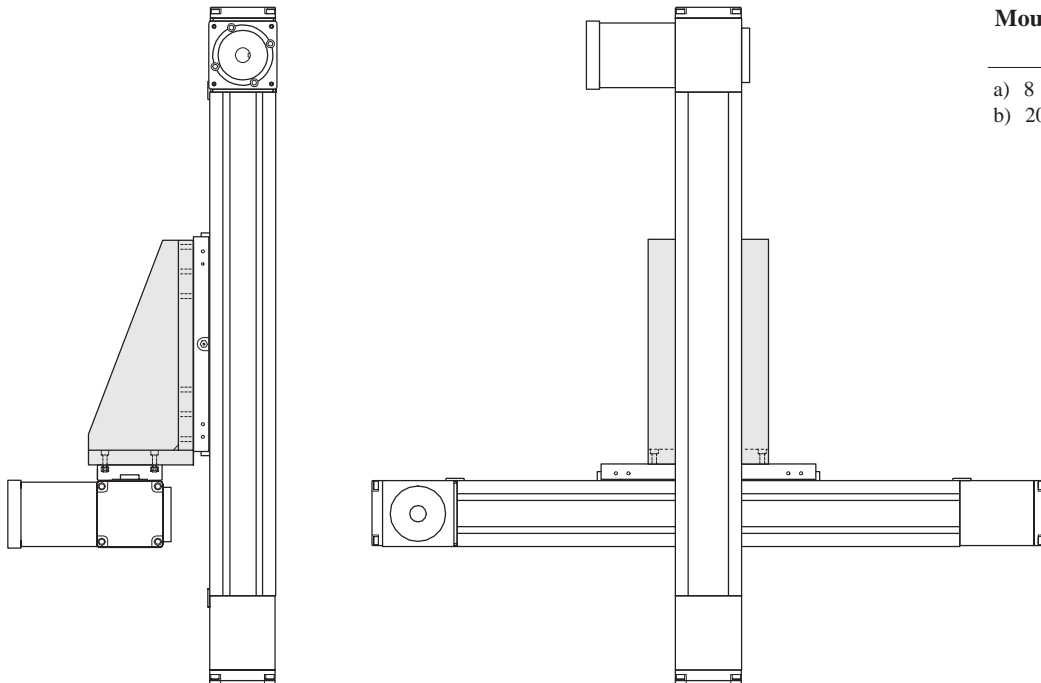

Multi-Axis Configurations

LINTECH can provide various adapter plates, horizontal adapter brackets, and vertical adapter brackets to facilitate the construction of X-Y, X-Z, and X-Y-Z multiple axis configurations using its many different standard positioning systems.

(X-Y) Configurations

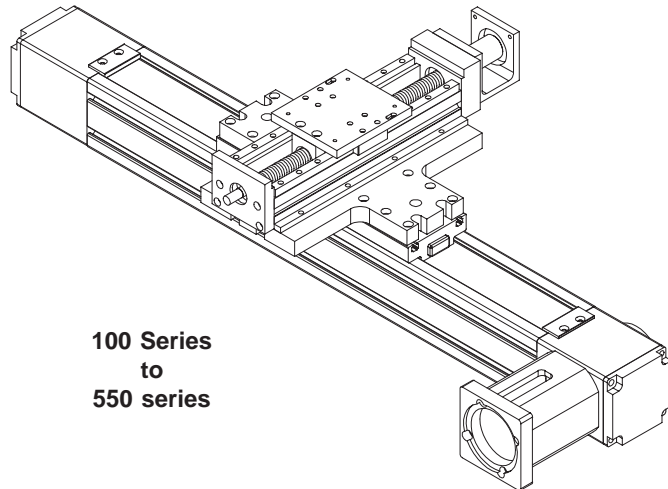

100 Series
to
550 series

150 Series
to
550 series

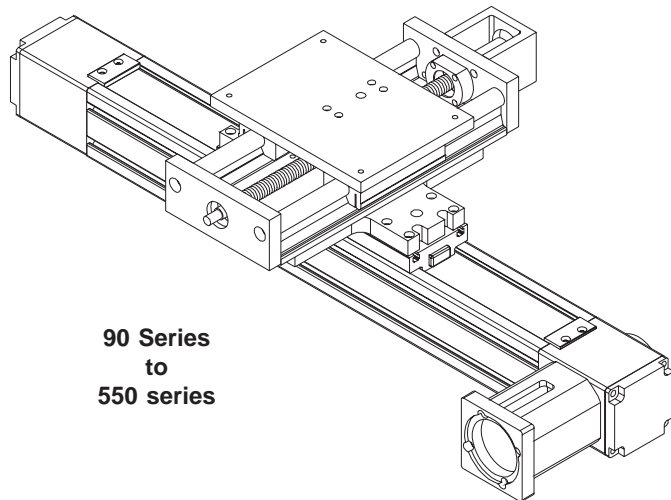
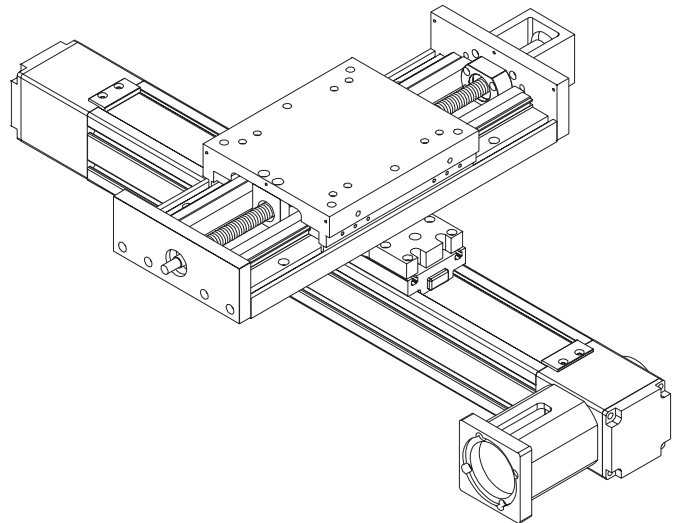

90 Series
to
550 series

Multi-Axis Configurations

LINTECH can provide various adapter plates, horizontal adapter brackets, and vertical adapter brackets to facilitate the construction of X-Y, X-Z, and X-Y-Z multiple axis configurations using its many different standard positioning systems.

(X-Z) Configurations

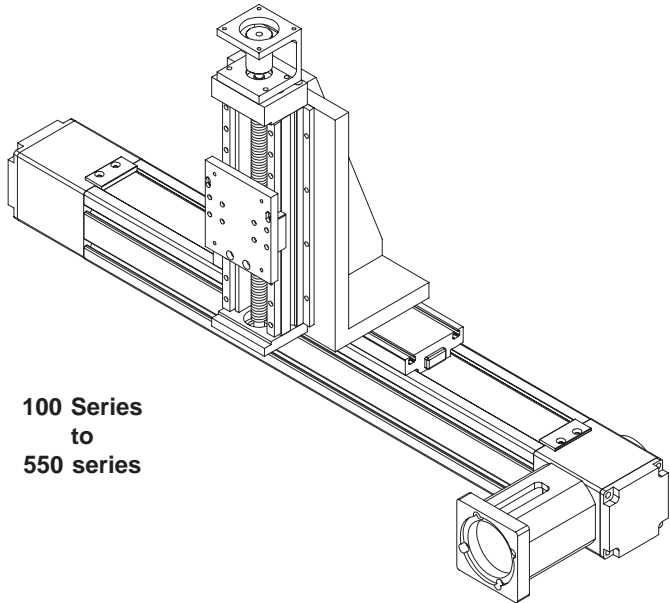

100 Series
to
550 series

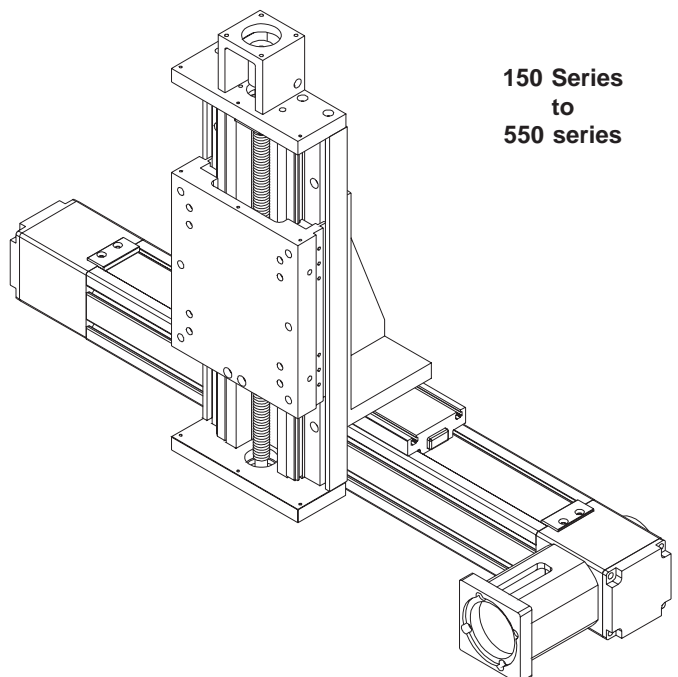

150 Series
to
550 series

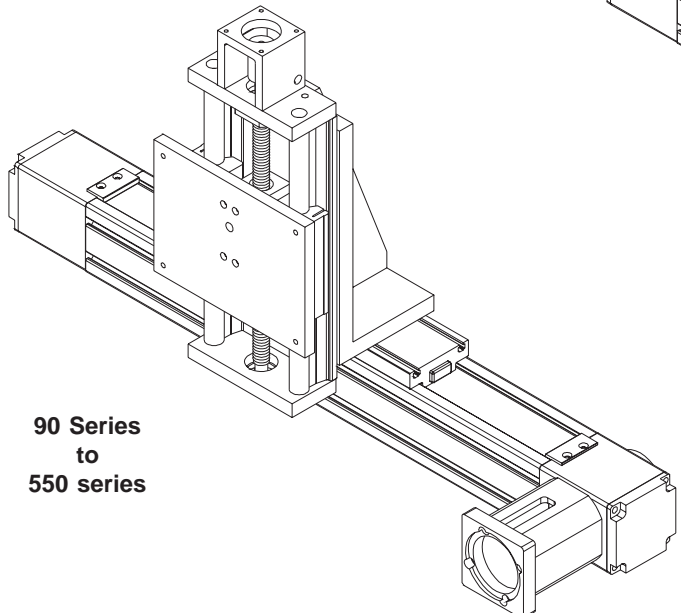

90 Series
to
550 series

K

Specifications subject to change without notice

Planetary Gearheads

For some 550 series belt drive positioning table applications, a NEMA gearhead may be required to increase motor speed and torque, while reducing the reflected load inertia that the motor sees. *LINTECH* offers two different styles of gearheads for its 550 series belt drive tables. The in-line version is ideal for those applications where the motor needs to be perpendicular to the table, while the right angle version will "wrap" the motor along side the table. Both gearheads come in either NEMA 34 or 42 frame sizes. When ordered with a 550 series table, the gearhead will be pre-mounted to the table by *LINTECH*. A motor shaft "sleeve", "clamp style mounting hub", and all mounting hardware, is provided with each gearhead. The self-aligning mounting hub maintains concentricity between the motor shaft and the gearhead. A motor adapter bracket, between the motor & gearhead, can also be provided for motors with non-NEMA mounting standards.

Model Number	Ratio	Peak Torque in-lbs (N-m)	Torque Output (5,000 hour life)			Torque Output (10,000 hour life)			Inertia in-lb-sec ² x 10 ⁻⁴ (kg-cm ²)	Torsional Stiffness in-lb/arc-min (N-m/arc-min)
			20 rps	50 rps	80 rps	20 rps	50 rps	80 rps		
GIL34-03	3:1	510 (58)	410 (46)	355 (40)	300 (34)	340 (38)	295 (33)	250 (28)	3.9 (0,44)	16.8 (1,9)
GIL34-05	5:1	700 (79)	535 (60)	428 (48)	360 (41)	445 (50)	355 (40)	300 (34)	1.2 (0,14)	16.8 (1,9)
GIL34-10	10:1	700 (79)	240 (27)	215 (24)	205 (23)	225 (25)	200 (23)	190 (21)	0.7 (0,08)	16.8 (1,9)
GRA34-01	1:1	493 (56)	160 (18)	153 (17)	140 (16)	150 (17)	142 (16)	130 (15)	27.5 (3,11)	12.6 (1,4)
GRA34-03	3:1	905 (102)	240 (27)	229 (26)	210 (24)	225 (25)	212 (24)	195 (22)	12.1 (1,37)	21.5 (2,4)
GRA34-05	5:1	1113 (126)	490 (55)	432 (49)	425 (48)	480 (54)	399 (45)	390 (44)	14.5 (1,64)	23.1 (2,6)
GRA34-10	10:1	1113 (126)	455 (51)	422 (48)	370 (42)	440 (50)	404 (46)	360 (41)	13.7 (1,54)	14.8 (1,7)
GIL42-03	3:1	1000 (113)	770 (87)	640 (72)	530 (60)	640 (72)	530 (60)	440 (50)	3.8 (0,43)	31.0 (3,5)
GIL42-05	5:1	1000 (113)	845 (95)	700 (79)	670 (76)	700 (79)	582 (66)	560 (63)	3.8 (0,43)	31.0 (3,5)
GIL42-10	10:1	1000 (113)	475 (54)	421 (48)	385 (44)	440 (50)	388 (44)	355 (40)	1.9 (0,21)	31.0 (3,5)
GRA42-01	1:1	1620 (183)	480 (54)	452 (51)	415 (47)	435 (49)	418 (47)	370 (42)	46.7 (5,28)	15.80 (1,7)
GRA42-03	3:1	2039 (230)	670 (76)	627 (71)	575 (65)	620 (70)	579 (65)	530 (60)	20.6 (2,33)	28.0 (3,2)
GRA42-05	5:1	2255 (255)	1305 (147)	1117 (126)	965 (109)	1100 (124)	907 (102)	790 (89)	24.6 (2,78)	30.0 (3,4)
GRA42-10	10:1	2255 (255)	1030 (116)	979 (111)	890 (101)	990 (112)	938 (106)	830 (94)	23.2 (2,63)	20.1 (2,3)

Note: The above gearheads have a backlash of 13 arc-minutes. Using any of the above gearheads in an application will add up to 0.0049 inch (0,012 mm) of backlash to the 550 series carriage. Therefore, the bidirectional repeatability of the carriage will change to +/- 0.0089 inches (0,226 mm). However, the unidirectional repeatability of the carriage will remain at +/- 0.001 inches (0,0254 mm). Also, gearheads with 4 arc-minutes backlash are available. This will add up to 0.0015 inch (0,038 mm) of backlash to the 550 series carriage.

Planetary Gearheads

In-line GIL34 & GIL42 series

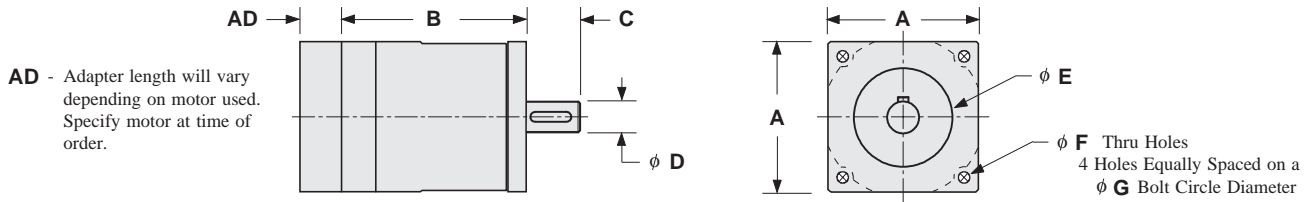

Model Number	A inches (mm)	B inches (mm)	C inches (mm)	D inches (mm)	E inches (mm)	F inches (mm)	G inches (mm)	Backlash arc-min	Weight lbs (kg)	Efficiency
GIL34-xx	3.622 (92,0)	2.470 (62,7)	1.575 (40,0)	.500 (12,7)	2.875 (73,03)	.218 (5,54)	3.875 (98,43)	13 max	8.0 (3,6)	90 %
GIL42-xx	4.606 (117,0)	3.060 (77,7)	1.969 (50,0)	.625 (15,9)	2.187 (55,55)	.281 (7,14)	4.950 (125,73)	13 max	15.0 (6,8)	90 %

Right Angle GRA34 & GRA42 series

Model Number	J inches (mm)	K inches (mm)	L inches (mm)
GRA34-xx (1:1 & 3:1)	2.47 (63)	3.99 (101)	5.76 (146)
GRA34-xx (5:1 & 10:1)	2.47 (63)	4.89 (124)	6.66 (169)
GRA42-xx (1:1 & 3:1)	3.02 (77)	5.40 (137)	7.67 (195)
GRA42-xx (5:1 & 10:1)	3.02 (77)	6.63 (168)	8.90 (226)

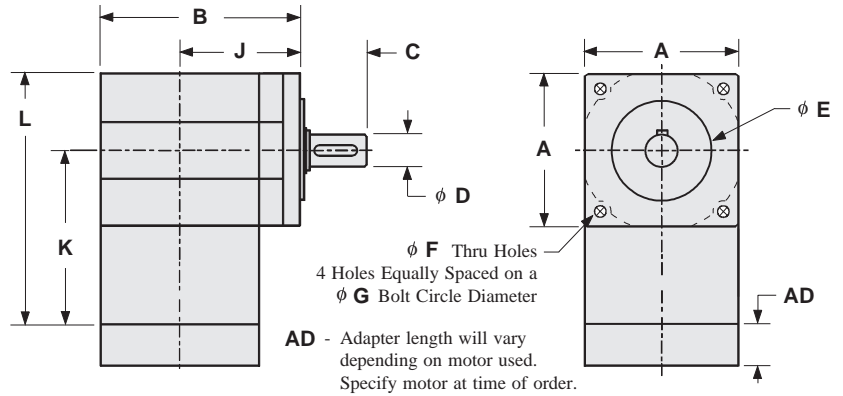

Model Number	A inches (mm)	B inches (mm)	C inches (mm)	D inches (mm)	E inches (mm)	F inches (mm)	G inches (mm)	Backlash arc-min	Weight lbs (kg)	Efficiency
GRA34-xx	3.250 (82,6)	4.240 (107,7)	1.250 (32,8)	.500 (12,7)	2.875 (73,03)	.218 (5,54)	3.875 (98,43)	13 max	6.0 (2,7)	90 %
GRA42-xx	4.250 (108,0)	5.280 (134,1)	1.500 (38,1)	.625 (15,9)	2.187 (55,55)	.281 (7,14)	4.950 (125,73)	13 max	12.0 (5,4)	90 %

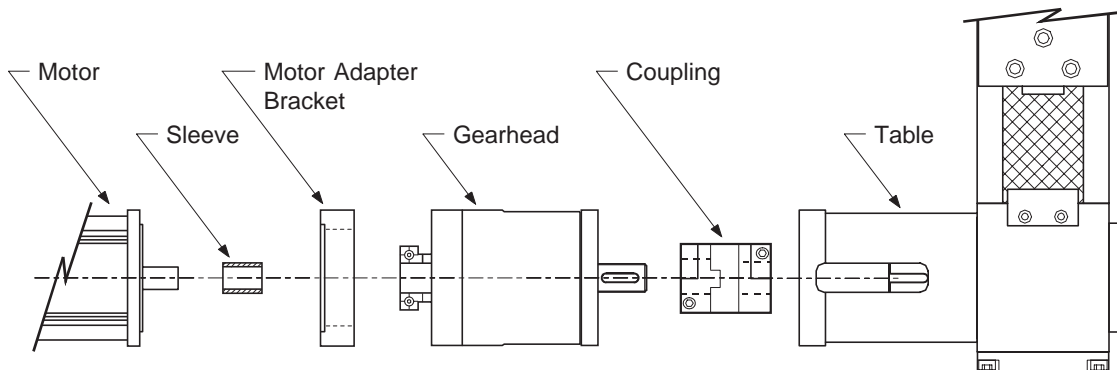

Specifications subject to change without notice

NEMA 34 & NEMA 42 Motor Mounts

NEMA 34 & 42 motor mounts can be ordered with either English, or Metric threads. *LINTECH* can provide adapter brackets for any step motor, or servo motor, that has other mounting requirements.

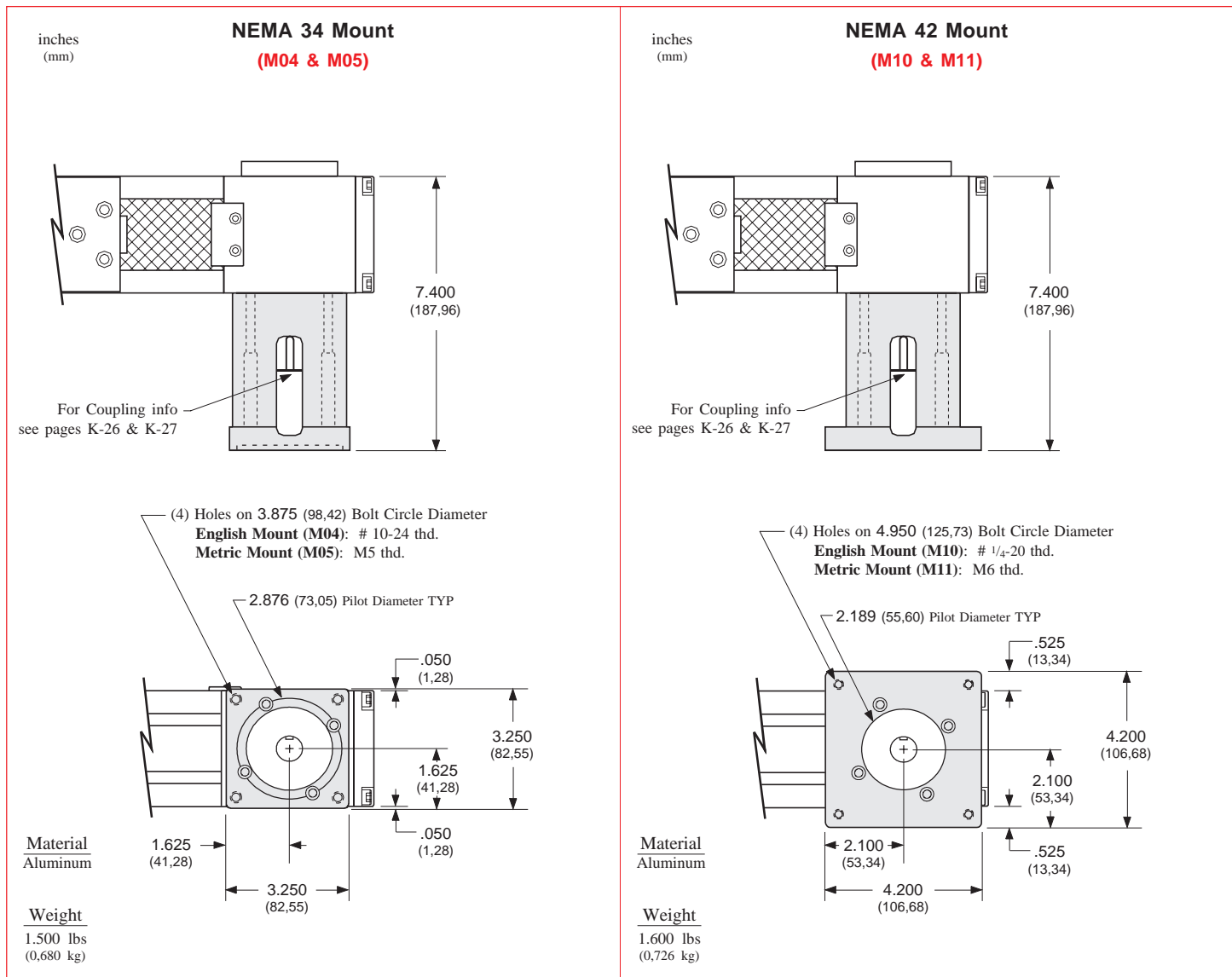

Chrome Plated Linear Bearings & Rails

For applications in high moisture, high humidity, clean room, or highly corrosive environments, chrome plating of the linear bearings, and linear rails, will offer superior resistance to corrosion than stainless steel components, resulting in longer table life. The process uniformly deposits dense, hard, high chromium alloy on the rails, and has a Rockwell C hardness value of 67-72. This process also conforms to MIL Spec: (MIL-C-23422). The chrome plating bonds to the parent material and will not crack or peel off under the high point loading of balls on the rail. This chrome plating process differs from a normal hard chrome plate which just lays on the surface of the part plated.

End of Travel (EOT) Switches & Home Switch

LINTECH provides several options for EOT & home switches. When ordered with a *LINTECH* 550 series table, each switch is mounted to the side of the table, while the actuating cams are mounted to the carriage assembly. The *T-slot* which runs along both sides of the 550 series, allows the switches to be located anywhere along the table. The switches are pre-wired by *LINTECH* for easy interfacing to the users Motion Controller.

End of Travel (EOT) Switches

End of travel (EOT) switches can be utilized by a motion controller to stop carriage motion, thereby preventing any damage to personnel, table carriage, or user mounted load if the extreme end of travel has been reached by the carriage. There are two EOT switches mounted to the side of the table, one on each end. The CCW switch is mounted at the motor mount end, while the CW switch is located at the opposite end of the table. *LINTECH* provides normally closed (NC) end of travel switches. This provides for a power-off fail safe system, where the position controller can detect broken wires. *It is highly recommended that any positioning table used with a position controller, should have end of travel switches installed for protection of personnel, table carriage, and user mounted load.*

Home Switch

The home switch can be utilized by a motion controller as a known fixed mechanical location on the positioning table. The switch is located between the EOT switches, near the motor mount end, and is a normally open (NO) switch.

Switch Locations

The following diagram shows the locations of the switches when ordered from *LINTECH*.

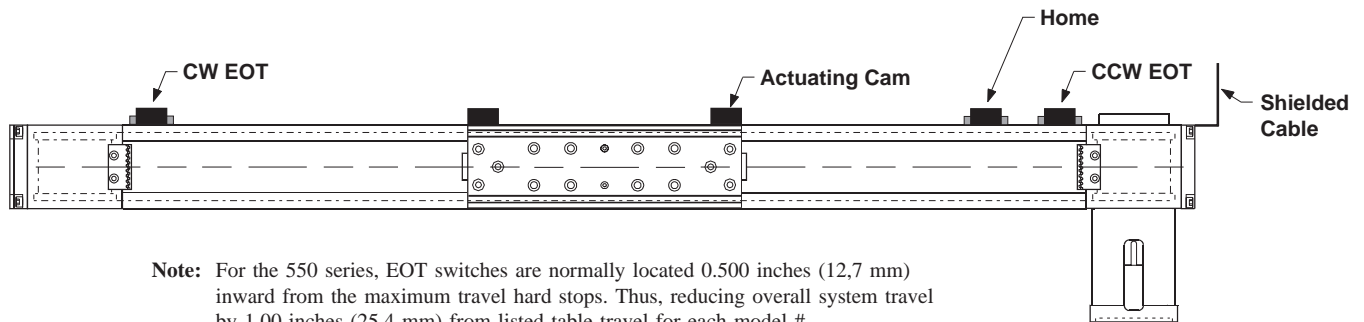

Note: For the 550 series, EOT switches are normally located 0.500 inches (12,7 mm) inward from the maximum travel hard stops. Thus, reducing overall system travel by 1.00 inches (25,4 mm) from listed table travel for each model #.

Note: Each switch can be located anywhere along the T-slots, which run on both sides of the table.

Switch Type	Cost	Repeatability inches (microns)	Actuated	Power Supply Required	Activation Area inches (mm)	Comments
reed	least expensive	+/- 0.0020 (50)	magnetic	No	0.30 (7,62)	for non-contact & low repeatable applications
hall effect	medium priced	+/- 0.0002 (5)	magnetic	Yes	0.32 (8,13)	for non-contact and wash down applications
proximity	most expensive	+/- 0.0002 (5)	non-magnetic	Yes	1.75 (44,45)	for non-contact, high speed, & wash down applications

K

Note: The repeatability of any switch is dependent upon several factors: carriage speed, accel rate, load weight, switch style, and the position controller. *LINTECH*'s ratings are based upon a carriage speed of 0.5 inches/sec (12.7 mm/sec) and a no load condition.

End of Travel (EOT) Switches & Home Switch

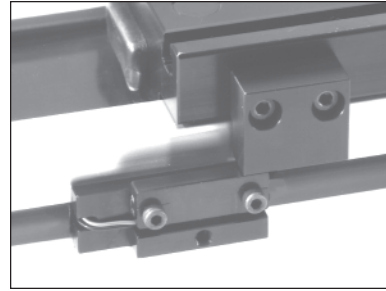
Non-Contact Reed Switches

Repeatability	: +/- 0.0020 inch (50 microns)
Electrical	: 1.0 amps @ 125 VAC 0.5 amps @ 100 VDC
Activation Style	: magnetic
Activation Area	: 0.30 inches (7,62 mm) of travel
Temperature Range	: - 10° C to + 60° C
Environment	: non wash down
Added Table Width	: 0.45 inch (11,4 mm) (EOT switches) 0.45 inch (11,4 mm) (Home switch)
Individual Switch Wiring	: 12 inch (305 mm) leads

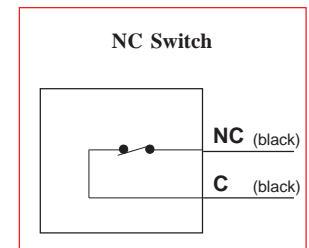
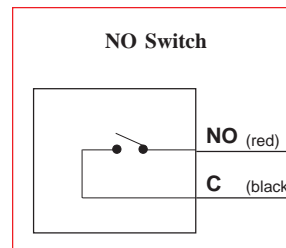

Standard *LINTECH* Wiring : from table end plate,
(provided when switch option is 10 foot (3 m) shielded cable,
ordered with any table) 6 conductor, 24 AWG,
unterminated leads

Wire Color	Description
Black	CW EOT (black) NC
Blue	CW Common (black)
Red	CCW EOT (black) NC
White	CCW Common (black)
Brown	HOME (red) NO
Green	HOME Common (black)
Silver	Shield

CW - Clockwise
CCW - Counter Clockwise
EOT - End of Travel
NC - Normally Closed
NO - Normally Open

End of Travel (EOT) Switches & Home Switch

Non-Contact Hall Effect Switches

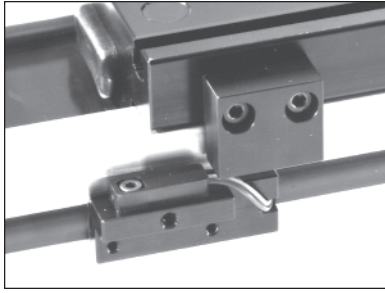

- Repeatability : +/- 0.0002 inch (5 microns)
- Electrical : 5 - 24 VDC
15 mA - power input
25 mA max - signal
- Actuation Style : magnetic
- Activation Area : 0.32 inches (8,13 mm) of travel
- Temperature Range : - 10° C to + 60° C
- Environment : wash down
- Added Table Width : 0.45 inch (11,4 mm) (EOT switches)
0.45 inch (11,4 mm) (Home switch)
- Individual Switch Wiring : 12 inch (305 mm) leads

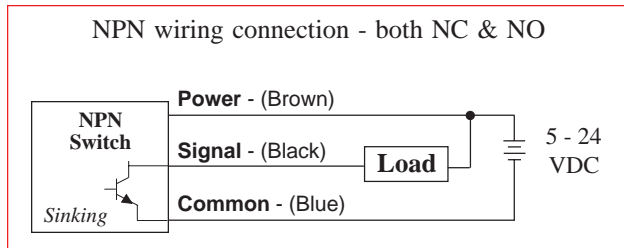

Standard *LINTECH* Wiring : from table end plate,
(provided when switch option is ordered with any table) 10 foot (3 m) shielded cable;
9 conductor, 24 AWG, unterminated leads

Wire Color	Description		
Brown	CW Power	(brown)	switch NC
Black	CW EOT	(black)	
Blue	CW Common	(blue)	
Red	CCW Power	(brown)	switch NC
White	CCW EOT	(black)	
Green	CCW Common	(blue)	
Orange	Home Power	(brown)	switch NO
Yellow	Home	(black)	
Grey	Home Common	(blue)	
Silver	Shield		

Non-Contact Proximity Switches

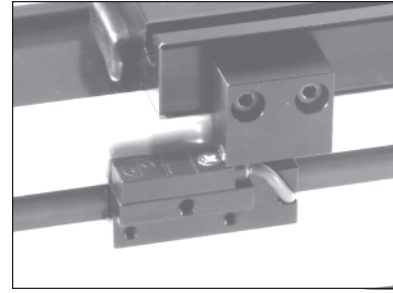

- Repeatability : +/- 0.0002 inch (5 microns)
- Electrical : 10 - 28 VDC
15 mA - power input
100 mA max - signal
- Actuation Style : non-magnetic cam
- Activation Area : 1.75 inches (44,45 mm) of travel
- Temperature Range : - 25° C to + 75° C
- Environment : IEC IP67 wash down
- Added Table Width : 0.45 inch (11,4 mm) (EOT switches)
0.45 inch (11,4 mm) (Home switch)
- Individual Switch Wiring : 6.5 foot (2 m) cable for NPN
3.3 foot (1 m) cable for PNP

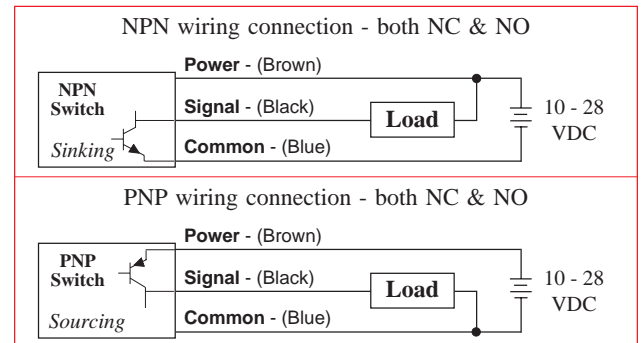

Standard *LINTECH* Wiring : from table end plate,
(provided when switch option is ordered with any table) 10 foot (3 m) shielded cable;
9 conductor, 24 AWG, unterminated leads

Wire Color	Description		
Brown	CW Power	(brown)	switch NC
Black	CW EOT	(black)	
Blue	CW Common	(blue)	
Red	CCW Power	(brown)	switch NC
White	CCW EOT	(black)	
Green	CCW Common	(blue)	
Orange	Home Power	(brown)	switch NO
Yellow	Home	(black)	
Grey	Home Common	(blue)	
Silver	Shield		

Specifications subject to change without notice

Motor Couplings

LINTECH provides three different types of couplings that can be used to mount a motor to a positioning table. These couplings compensate for misalignment between the motor shaft & belt drive shaft extension. This provides for trouble-free operation as long as certain precautions are taken. The connected motor output torque should never exceed the coupling maximum torque capacity. Larger capacity couplings may be required for applications having high accelerations, large back driving loads, high torque output motors, or servo motors.

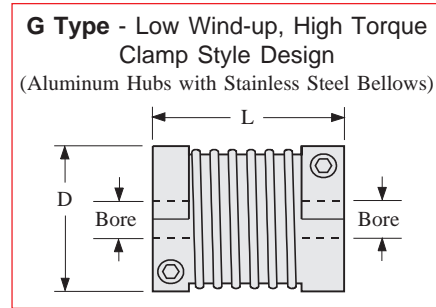
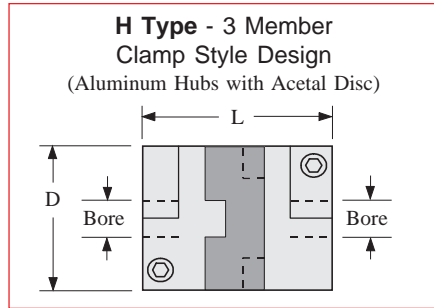

Model #	D inches (mm)	L inches (mm)	Bore Diameters				Weight ounces (grams)	Inertia oz-in ² (g-cm ²)	Wind-up arc-sec/oz-in (deg/N-m)	Max Torque oz-in (N-m)
			Table	Motor	Minimum (in) (mm)	Maximum (in) (mm)				
H197-018-aaa	1.97 (50,0)	2.35 (59,7)	018	aaa	.375 10	.750 20	7.6 (215)	3.69 (674)	1.1 (0,043)	3,600 (25,4)
H225-018-aaa	2.25 (57,2)	3.07 (78,0)	018	aaa	.500 12	1.000 24	13.1 (371)	8.29 (1516)	0.6 (0,024)	5,300 (37,4)
G177-018-aaa	1.77 (45,0)	2.48 (63,0)	018	aaa	.375 10	.750 20	7.1 (200)	2.78 (508)	0.2 (0,008)	4,250 (30,0)
G220-018-aaa	2.20 (56,0)	2.56 (65,0)	018	aaa	.500 12	1.000 24	10.6 (300)	6.41 (1172)	0.04 (0,002)	7,100 (50,0)
G260-018-aaa⁽¹⁾	2.60 (66,0)	3.07 (78,0)	018	aaa	.625 16	1.000 24	21.2 (600)	17.91 (3276)	0.03 (0,001)	9,600 (68,0)
Possible values for aaa	375 = .375 inch 500 = .500 inch 625 = .625 inch 750 = .750 inch		999 = 1.000 inch		010 = 10 mm 012 = 12 mm 014 = 14 mm 016 = 16 mm		018 = 18 mm 019 = 19 mm 020 = 20 mm 024 = 24 mm			

Footnotes:

(1) This coupling option can not be used with the optional NEMA 34 & 42 motor mounts because its diameter is too large. Custom motor mounts can be provided upon request. See page K-27 for maximum coupling diameter and length specifications for use with the optional NEMA 34 & 42 motor mounts.

Motor Couplings

Coupling	Cost	Torque Capacity	Wind-up	Suggested Motor	Comments
H Type	less expensive	medium	medium	stepper or servo	use for high accels & for starting & stopping large inertia loads
G Type	more expensive	high	the least	servo	use for very high torque requirements & very high servo accelerations

Specification	550 Series
	NEMA 34 & 42 bracket inches (mm)
Shaft extension diameter at motor mount end	0.709 (18,0)
Maximum coupling diameter	2.300 (58,42)
Maximum coupling length	3.100 (78,74)
Note: Custom brackets available upon request.	

Coupling Part Numbers

C293 H197-018-375	C359 H225-018-500	C573 G177-018-375	C639 G220-018-500	C684 G260-018-625
C294 H197-018-500	C360 H225-018-625	C574 G177-018-500	C640 G220-018-625	C685 G260-018-750
C295 H197-018-625	C361 H225-018-750	C575 G177-018-625	C641 G220-018-750	C686 G260-018-999
C296 H197-018-750	C362 H225-018-999	C576 G177-018-750	C642 G220-018-999	C687 G260-018-016
C297 H197-018-010	C363 H225-018-012	C577 G177-018-010	C643 G220-018-012	C688 G260-018-018
C298 H197-018-012	C364 H225-018-014	C578 G177-018-012	C644 G220-018-014	C689 G260-018-019
C299 H197-018-014	C365 H225-018-016	C579 G177-018-014	C645 G220-018-016	C690 G260-018-020
C300 H197-018-016	C366 H225-018-018	C580 G177-018-016	C646 G220-018-018	C691 G260-018-024
C301 H197-018-018	C367 H225-018-019	C581 G177-018-018	C647 G220-018-019	
C302 H197-018-019	C368 H225-018-020	C582 G177-018-019	C648 G220-018-020	
C303 H197-018-020	C369 H225-018-024	C583 G177-018-020	C649 G220-018-024	

Power-off Electric Brakes

For vertical table applications, or for those applications requiring the load to be locked securely in place, an electric brake may be mounted to the positioning table. The 550 series will have the brake mounted to the "Thru Drive Shaft" option. With proper wiring from a control system, this power-off friction brake can ensure that the carriage is firmly held in place, when no electric power is applied to the brake. When power is applied to the brake, the brake is opened or "released".

For proper emergency braking of the 550 series table, this electric brake needs to be interfaced to a position controller or relay network. *LINTECH* also provides 24 & 90 VDC power supplies which can be used to power the brakes.

Brakes

Model Number	Holding Force		Excitation Voltage		Current		Weight	
	in-lbs (N-m)		volts		amps		lbs (kg)	
B05	180 (20,3)		24 VDC		1.136		4.8 (2,18)	
B06	180 (20,3)		90 VDC		0.287		4.8 (2,18)	

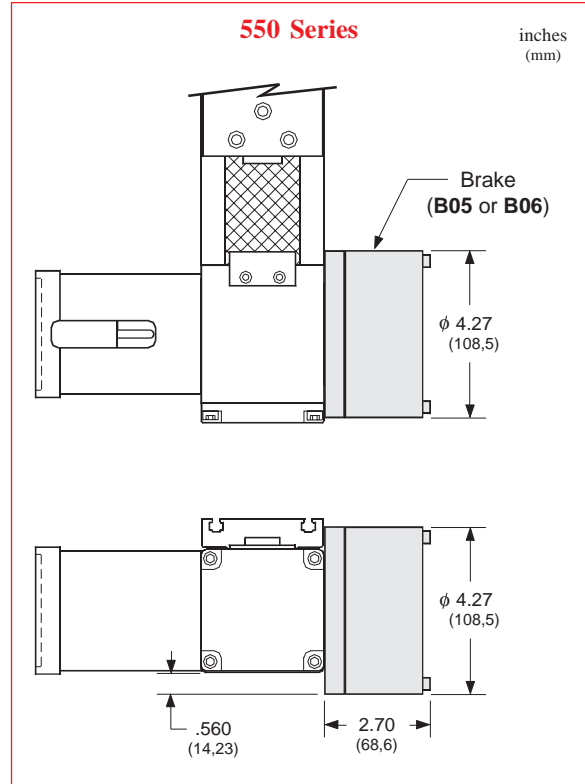

Note: This power-off electric brake **MUST NOT** be engaged when the positioning table is in motion. Moving the table with the brake applied could damage the brake and the positioning table. Also, continuous use of this brake to stop a table (load) that is in motion could damage the brake and the positioning table. Dynamic braking of a positioning table should be done by the motor and not the brake.

Power Supplies

Model Number	DC Output			AC Input		
	volts	amps	style	volts	amps	Hz
41970	5	3.0	regulated	120 / 240	0.8 / 0.4	47-63
37488	24	1.2	regulated	120 / 240	0.8 / 0.4	47-63
37489	90	0.8	unregulated	120	1.0	50/60
37490	90	0.8	unregulated	240	0.5	50/60

Rotary Incremental Encoders

Shaftless, incremental, optical rotary encoders can be mounted to the "Thru Drive Shaft" option on the 550 series positioning tables. These encoders provide positional feedback to either a motion controller, or a digital position display.

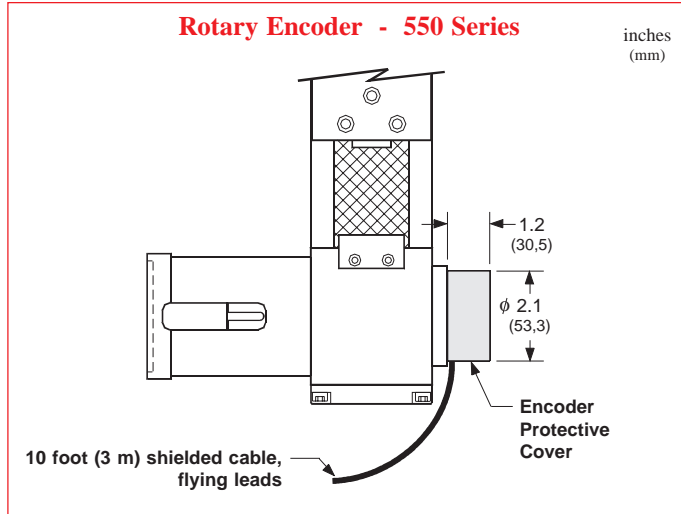

Wire Color	Description
White	Channel A+ (or A)
Blue	Channel A- (or \bar{A})
Green	Channel B+ (or B)
Orange	Channel B- (or \bar{B})
White/Black	Channel Z+ (or Z)
Red/Black	Channel Z- (or \bar{Z})
Black	Common
Red	+ 5 vdc (+/- 5%)

Specification	ROTARY ENCODERS		
	E01	E02	E03
Line Count	500 lines/rev	1000 lines/rev	1270 lines/rev
Pre Quadrature Resolution	0.002 revs/pulse	0.001 revs/pulse	0.00079 revs/pulse
Post Quadrature Resolution	0.0005 revs/pulse	0,00025 revs/pulse	0.00019 revs/pulse
Maximum Speed	50 revs/sec		
Maximum Accel	40 revs/sec ²		
Excitation Power	+ 5 VDC @ 125 ma		
Operating Temperature	32 ^o F to 140 ^o F (0 ^o C to 60 ^o C)		
Humidity	20% to 80% non condensing		
Shock	10 G's for 11 msec duration		
Weight	0.7 lbs (0,283 kg)		
Cable Length	10 ft (3 m), unterminated 26 gauge leads		
Zero Reference Output	Once per revolution		
Outputs	TTL square wave; Two channel (A+ & B+); Differential (A- & B-); Line Driver		

