

300 & 400 Series Positioning Tables

300 Series Introduction	L-2
400 Series Introduction	L-3
Specifications	L-5
300 Series Dimensions	L-6
400 Series Dimensions	L-7
300 Series Motor Couplings	L-8
300 Series NEMA 34 Option	L-9
Home Switch Options	L-10



Single Axis Rotary Table

LINTECH's 300 series positioning tables offer precision performance and design flexibility for use in a wide variety of Motion Control applications.

- *Welding*
- *Test Stands*
- *Part Insertion*
- *Laser Positioning*
- *Liquid Dispensing*
- *Semiconductor Processing*
- *Gluing*
- *Pick & Place*
- *Part Scanning*
- *Inspection Stations*
- *General Automation*

Quality Construction

These tables feature a rigid pair of quality angular contact bearings which produce smooth table top rotation. The low backlash precision worm gear drive provides exceptional accuracy and repeatability. Load capacities to 225 pounds (102 kg) are available, with table top diameters of 6, 8, 10, and 12 inches. All aluminum components have a black anodized finish and each table has a standard NEMA 23 motor mount. Threaded steel inserts in the table top provide for easy mounting of the user load, while the 0.75 inch (19 mm) diameter through hole provides easy access from below. With 3 different gear ratios for each table top, the 300 series tables perform well in either high speed or high resolution applications. Mounting a 300 series rotary table directly to any of LINTECH's linear positioning tables, produces a unique multi-axis system.

Standard Features - 300 Series

- Worm gear drive
- Standard & Precision versions
- NEMA 23 & 34 motor mounts
- 45, 90, & 180:1 gear reductions
- Load capacity to 225 lbs (102 kg)
- 30 revs/sec maximum input speed
- 6, 8, 10, & 12 inch table top diameters
- 10 arc-sec unidirectional repeatability
- 0.75 inch (19 mm) diameter through hole
- English & Metric inserts for load mounting

300 Series



Single Axis Rotary Table

LINTECH's 400 series positioning tables offer precision performance and design flexibility for use in a wide variety of Motion Control applications.

- *Welding*
- *Test Stands*
- *Part Insertion*
- *Laser Positioning*
- *Liquid Dispensing*
- *Semiconductor Processing*
- *Gluing*
- *Pick & Place*
- *Part Scanning*
- *Inspection Stations*
- *General Automation*

Quality Construction

These tables feature a rigid pair of 4 point contact radial bearings which produce smooth table top rotation. The low backlash precision worm gear drive provides years of exceptional accuracy and repeatability. This rugged construction offers load capacities to 1000 pounds (453 kg) with a 5.48 inch (139 mm) table top diameter. Threaded steel inserts in the table top provide for easy mounting of the user load, while the 4.5 inch (114 mm) diameter through hole provides easy access from below. The NEMA 34 mount can be rotated 360 degrees around either side of the table. With 5 different gear ratios, the 400 series tables perform well in either high speed or high resolution applications.

Standard Features - 400 Series

- Worm gear drive
- NEMA 34 motor mount
- Standard & Precision versions
- 9 revs/sec maximum input speed
- English inserts for load mounting
- Load capacity to 1,000 lbs (453 kg)
- 5.48 inch (139 mm) table top diameter
- 12 arc-sec unidirectional repeatability
- 4.5 inch (114 mm) diameter through hole
- 30, 90, 180, 270, & 360:1 gear reductions

400 Series

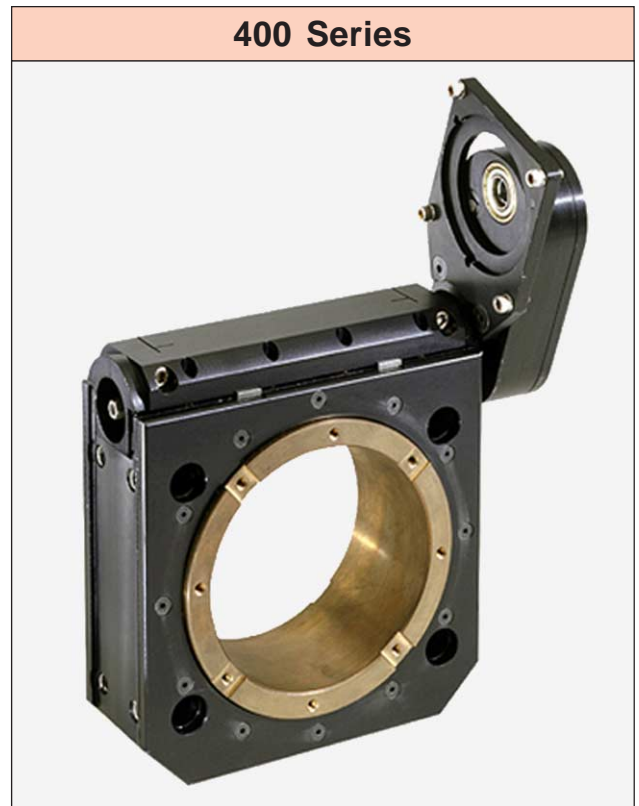

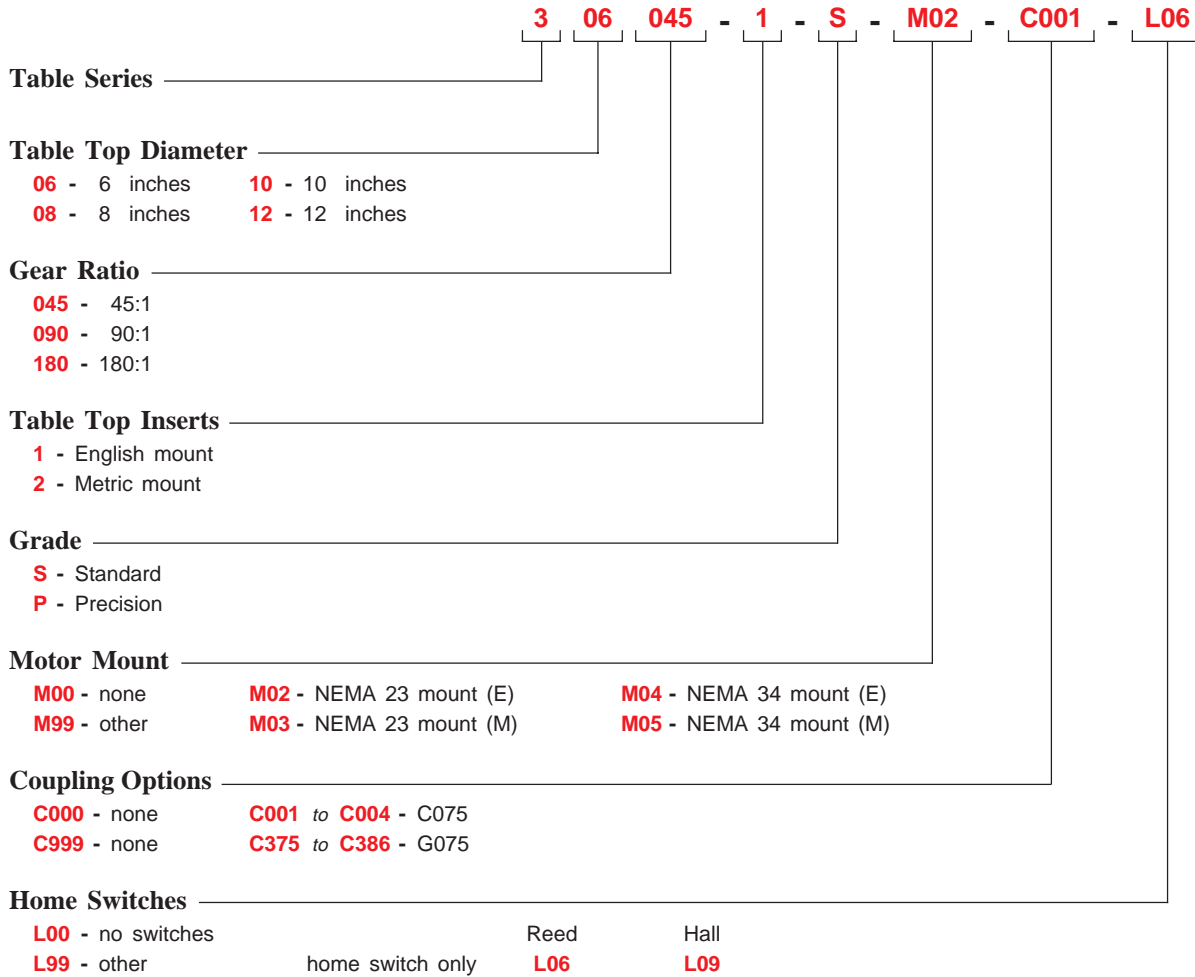

(E) - English Interface
(M) - Metric Interface

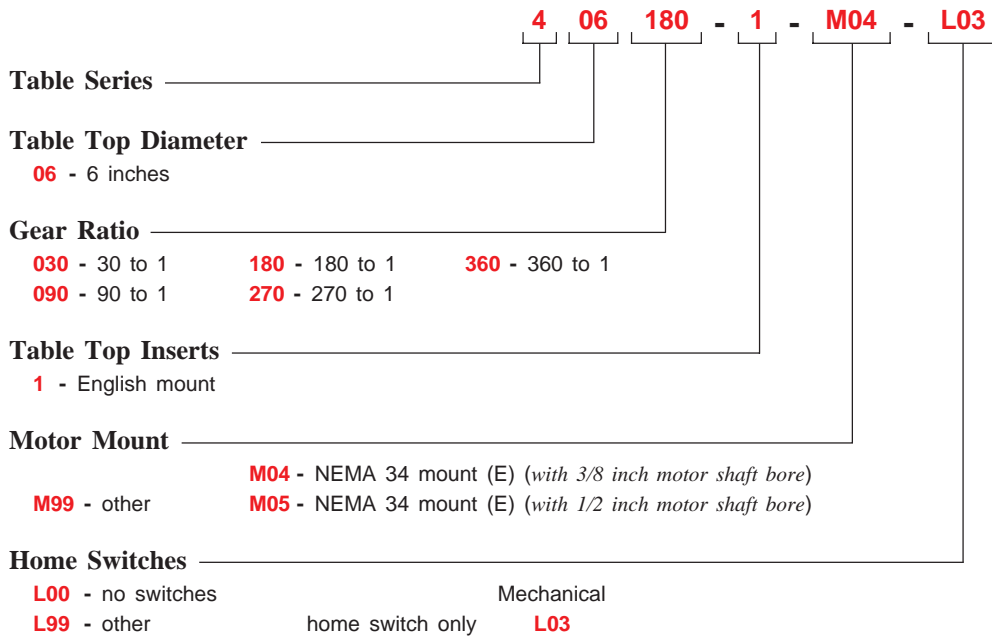

(E) - English Interface

Specifications

Made in the U.S.A.

Load Capacities	300 series ⁽¹⁾	400 series ⁽¹⁾
Dynamic Horizontal (1 million revs)	225 lbs (102 kg)	1000 lbs (453 kg)
Dynamic Inverted (1 million revs)	100 lbs (45 kg)	1000 lbs (453 kg)
Static Horizontal	250 lbs (113 kg)	1000 lbs (453 kg)
Dynamic Moment (1 million revs)	20 ft-lbs (27 N-m)	225 ft-lbs (305 N-m)
Static Moment	25 ft-lbs (34 N-m)	250 ft-lbs (339 N-m)
Maximum Input Speed	30 rev/sec	9 rev/sec
Maximum Input Acceleration	75 rev/sec ²	50 rev/sec ²

Other	300 series	400 series
Table Material	Base & Table Top - 6061 black anodized aluminum	
Worm Wheel Type	Bronze (AGMA - class 10)	
Worm Gear Type	Steel (AGMA - class 10)	
Duty Cycle	60 %	
(gear ratio)	45:1 90:1 180:1	30:1 90:1 180:1 270:1 360:1
Maximum Table Top Speed	40 rpm 20 rpm 10 rpm	18 rpm 6 rpm 3 rpm 2 rpm 1.5 rpm
Worm Gear Efficiency	50 % 60 % 70 %	50 % 60 % 60 % 60 % 60 %
Worm Gear Inertia (oz-in ²)	0.03 0.03 0.03	0.10 0.10 0.13 0.16 0.19
Accuracy	< 150 arc-sec	
Unidirectional Repeatability	< 10 arc-sec	
Bidirectional Repeatability	< 40 arc-sec	
Backlash	< 30 arc-sec	
Runout (vertical runout)	Standard < 0.003 in (0,076 mm) ⁽²⁾ Precision < 0.001 in (0,025 mm) ⁽²⁾	< 0.002 in (0,05 mm) ⁽³⁾
Concentricity (radial runout)	Standard < 0.003 in (0,076 mm) ⁽⁴⁾ Precision < 0.001 in (0,025 mm) ⁽⁴⁾	< 0.002 in (0,05 mm) ⁽⁵⁾
Wobble (axis runout)	Standard < 80 arc-sec ⁽⁶⁾ Precision < 40 arc-sec ⁽⁶⁾	< 60 arc-sec ⁽⁶⁾
Breakaway Torque	< 20 oz-in (0,141 N-m)	
	< 60 oz-in (0,424 N-m)	

Footnotes:

- (1) Dynamic load capacities & life are limited by the stresses exerted upon the worm gear assembly.
- (2) Measured at 6 inches (152,4 mm) from table top center. Total indicator runout.
- (3) Measured at 5.5 inches (139,7 mm) from table top center. Total indicator runout.
- (4) Measured at 0.75 inches (19,1 mm) from table top center. Total indicator runout.
- (5) Measured at 4.5 inches (114,3 mm) from table top center. Total indicator runout.
- (6) Based on the centerline of the table top.

Dimensions & Specifications

Made in the U.S.A.

Model Number	Table Dimensions inches (mm)				Mounting Dimensions inches (mm)					Table Top Weight	Table Weight
	A	B	C	D	E	F	G	H	I	lbs (kg)	lbs (kg)
306xxx-1-S	6.000 (152,4)	0.375 (9,5)	2.500 (63,5)	2.930 (74,4)	5.000 (127,0)	4.000 (101,6)	2.500 (63,5)	6.000 (152,4)	2.000 (50,8)	1.1 (0,5)	11.0 (5,0)
308xxx-1-S	8.000 (203,2)	0.500 (12,7)	2.500 (63,5)	3.055 (77,6)	6.000 (152,4)	4.000 (101,6)	2.500 (63,5)	6.000 (152,4)	2.000 (50,8)	2.5 (1,2)	12.0 (5,4)
310xxx-1-S	10.000 (254,0)	0.750 (19,0)	2.650 (67,3)	3.455 (87,8)	8.000 (203,2)	6.000 (152,4)	4.500 (114,3)	10.000 (254,0)	0.250 (6,3)	5.7 (2,6)	33.0 (15,0)
312xxx-1-S	12.000 (304,8)	0.750 (19,0)	2.650 (67,3)	3.455 (87,8)	10.000 (254,0)	8.000 (203,2)	4.500 (114,3)	10.000 (254,0)	0.250 (6,3)	7.2 (3,3)	36.0 (16,3)

- xxx = 045; 45 to 1 gear ratio
- xxx = 090; 90 to 1 gear ratio
- xxx = 180; 180 to 1 gear ratio

Dimensions

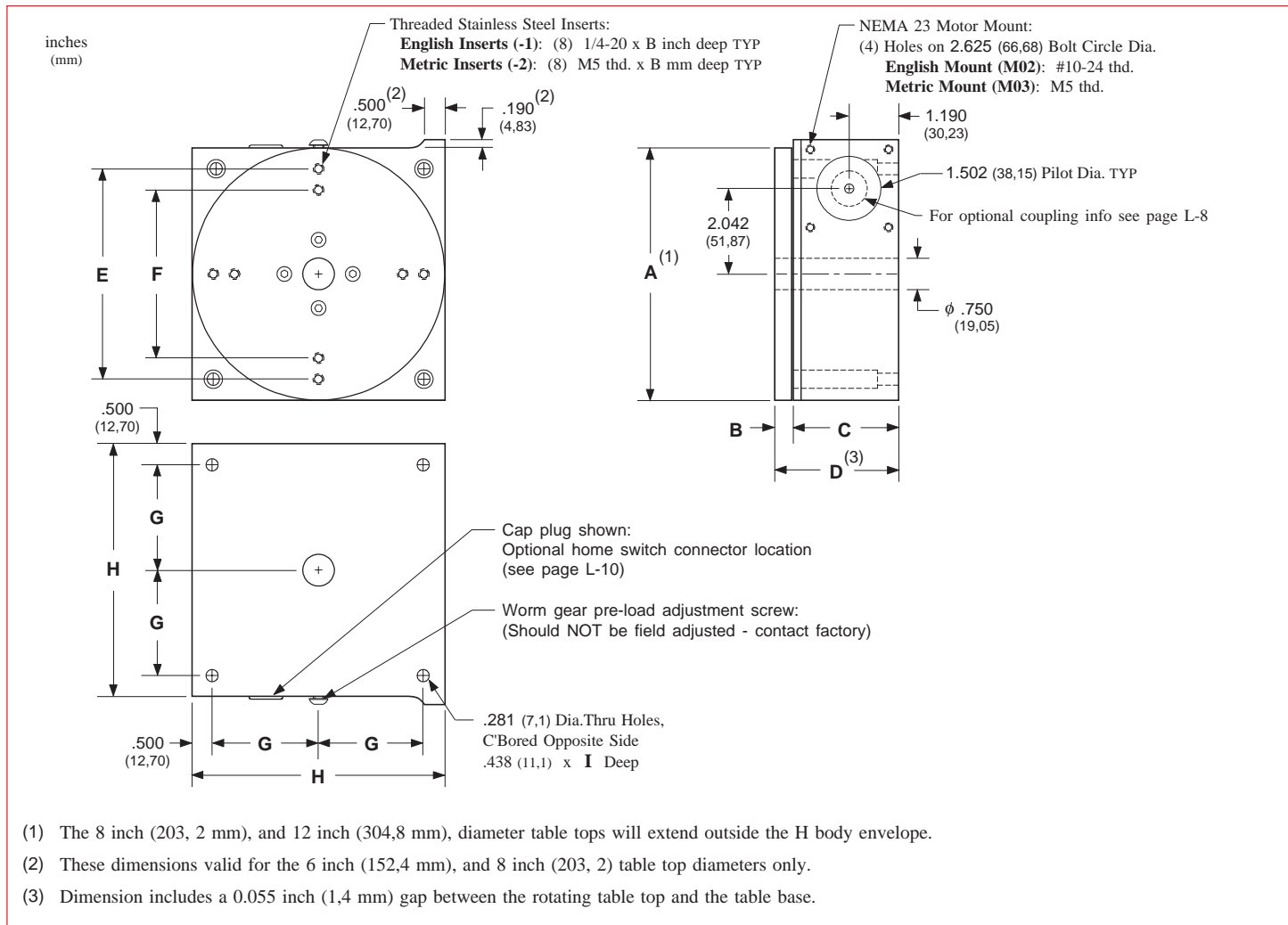

Dimensions & Specifications

Model Number	Table Top Diameter inches (mm)	Table Top Weight lbs (kg)	Table Weight lbs (kg)
406xxx-1	5.480 (139,2)	3.0 (1,4)	13.5 (6,2)

- xxx = 030; 30 to 1 gear ratio
- xxx = 090; 90 to 1 gear ratio
- xxx = 180; 180 to 1 gear ratio
- xxx = 270; 270 to 1 gear ratio
- xxx = 360; 360 to 1 gear ratio

Dimensions

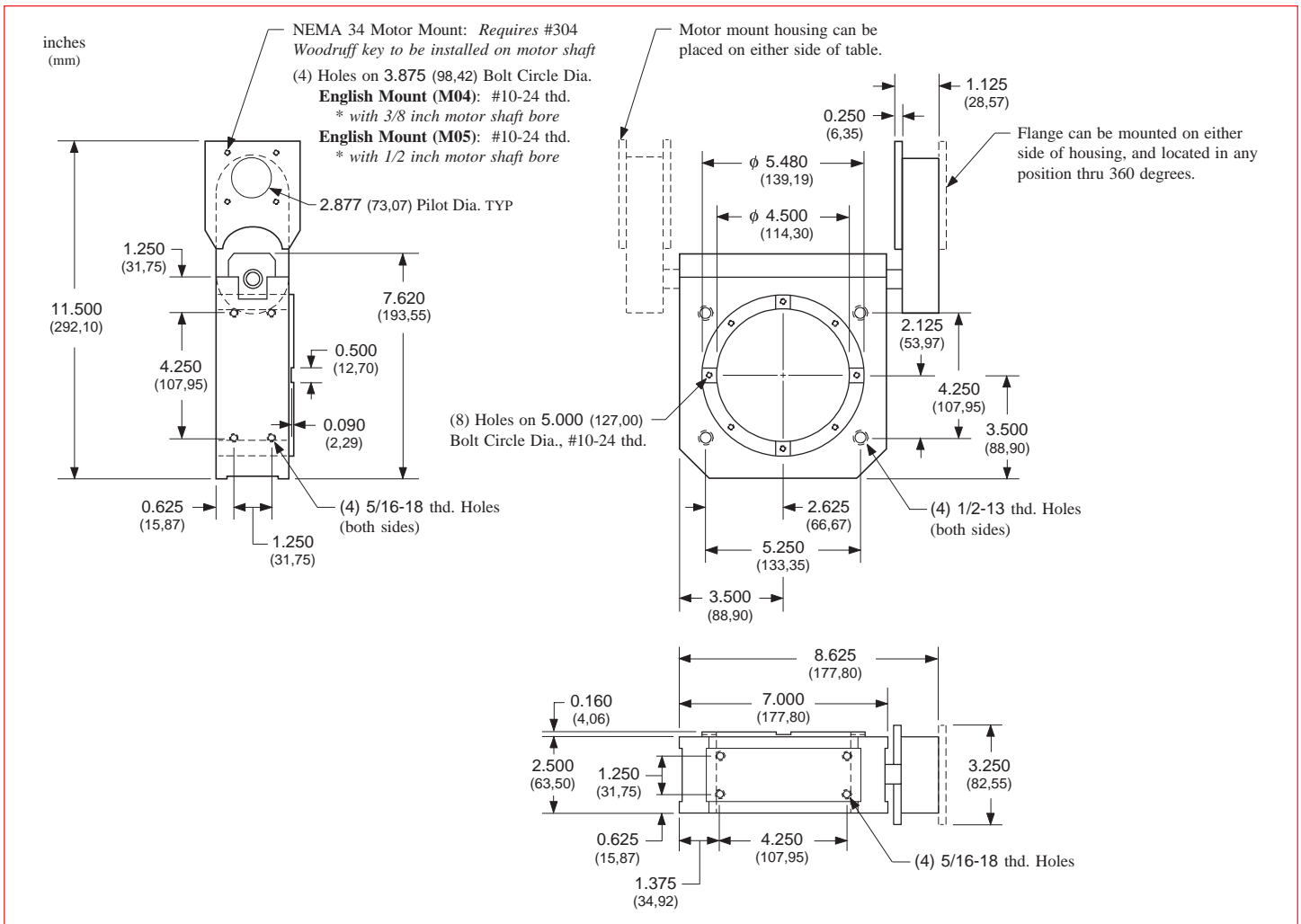

Motor Couplings

LINTECH provides two different types of couplings that can be used to mount a motor to a 300 series positioning table. These couplings compensate for misalignment between the motor shaft & worm gear drive shaft extension. This provides for trouble-free operation as long as certain precautions are taken. The connected motor output torque should never exceed the coupling maximum torque capacity. Larger capacity couplings may be required for applications having high accelerations, large back driving loads, high torque output motors, or servo motors.

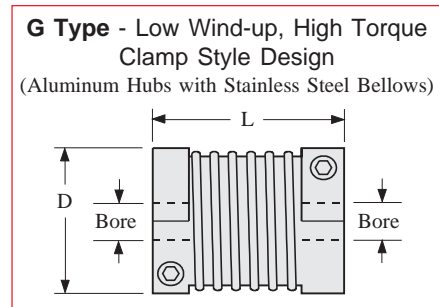
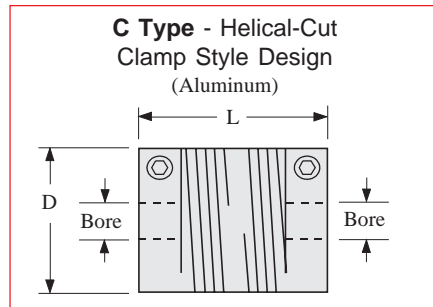

Model # ⁽¹⁾	D inches (mm)	L inches (mm)	Bore Diameters				Weight ounces (grams)	Inertia oz-in ² (g-cm ²)	Wind-up arc-sec/oz-in (deg/N-m)	Max Torque oz-in (N-m)
			Table	Motor	Minimum (in) (mm)	Maximum (in) (mm)				
C075-187-aaa	0.75 (19,1)	1.00 (25,4)	187	aaa	.187 5	.250 8	0.8 (23)	.06 (10)	45.0 (1,8)	200 (1,4)
G075-187-aaa	0.79 (20,0)	1.02 (26,0)	187	aaa	.187 5	.375 10	0.8 (23)	.06 (10)	2.0 (0,08)	300 (2,1)
G075-250-aaa ⁽²⁾	0.79 (20,0)	1.02 (26,0)	250	aaa	.187 5	.375 10	0.8 (23)	.06 (10)	2.0 (0,08)	300 (2,1)
Possible values for aaa	187 = .187 inch 250 = .250 inch 375 = .375 inch		005 = 5 mm 006 = 6 mm 008 = 8 mm 010 = 10 mm							

Footnotes:

- (1) 0.85 inch (21,6 mm) is the largest diameter coupling allowed to be used with the 300 series because of the internal motor mount clearance.
- (2) This coupling option can not be used with any NEMA 23 motor mount. Also, it can not be used with the optional NEMA 34 motor mount for the 6 and 10 inch table top models. It can only be used with the optional NEMA 34 motor mount for the 8 and 12 inch table top models.

Coupling Part Numbers

C001 C075-187-250	C375 G075-187-250
C002 C075-187-005	C376 G075-187-375
C003 C075-187-006	C377 G075-187-005
C004 C075-187-008	C378 G075-187-006
	C379 G075-187-008
	C380 G075-187-010
	C381 G075-250-250
	C382 G075-250-375
	C383 G075-250-005
	C384 G075-250-006
	C385 G075-250-008
	C386 G075-250-010

NEMA 34 Motor Mount

The 300 series NEMA 34 motor adapter bracket is an aluminum flange that mounts to the front of the NEMA 23 motor mount for the 6 & 10 inch table top diameters. For the 8 & 12 inch table top diameters, *LINTECH* provides a motor mount extension which allows for a NEMA 34 motor mount that will NOT contact the rotating table top. The bracket can be ordered in either an English, or Metric motor mount. *LINTECH* can provide adapter brackets for any step motor, or servo motor, that has other mounting requirements.

Material
Aluminum

Weight
.500 lbs
(0,227 kg)

(M04 & M05)

inches
(mm)

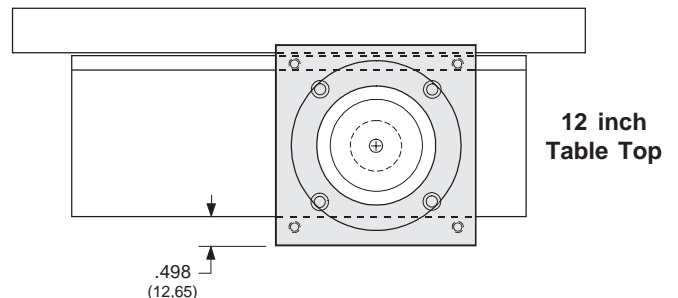
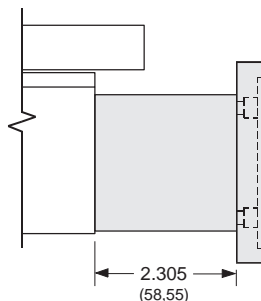
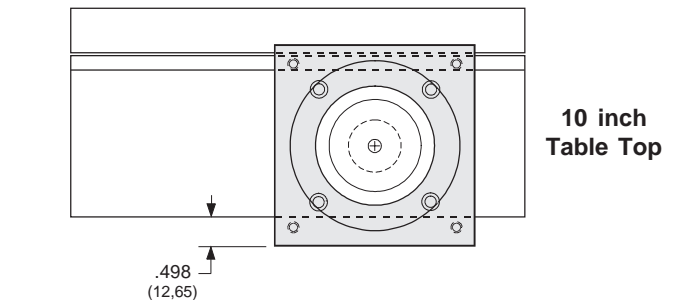
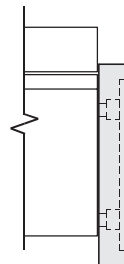
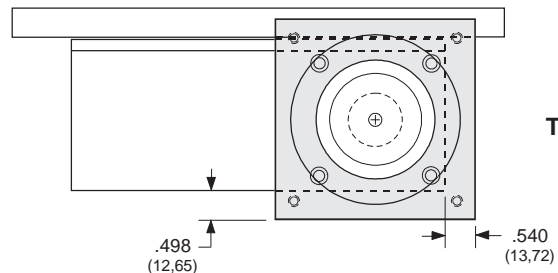
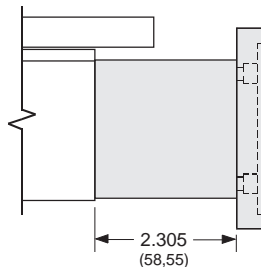
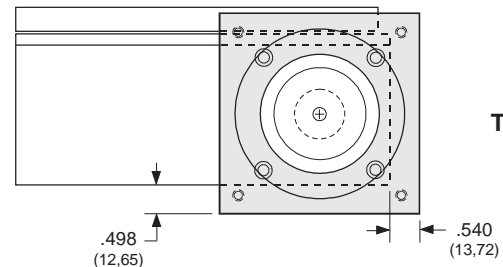
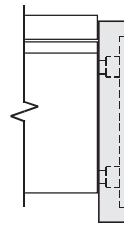
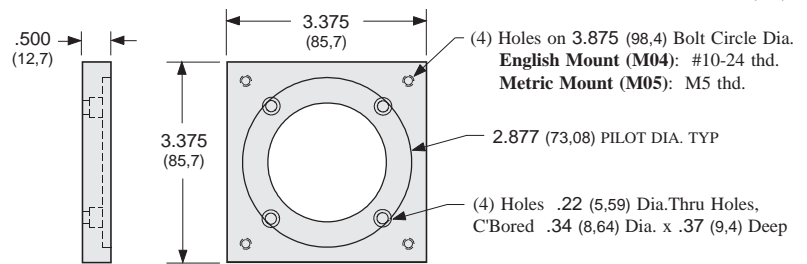

Specifications subject to change without notice

Home Switch

300 Series

The home switch option on the 300 series is mounted internally to the positioning table and is wired to a connector which is located on the side of the base. A mating connector with a 10 foot (3 m) shielded cable is provided with either the reed, or hall, home switch option.

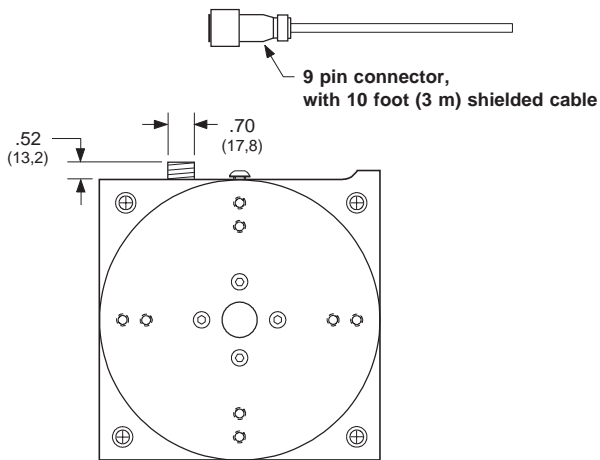

400 Series

The home switch option on the 400 series is mounted externally to the positioning table and is pre-wired with a 10 foot (3 m) shielded cable.

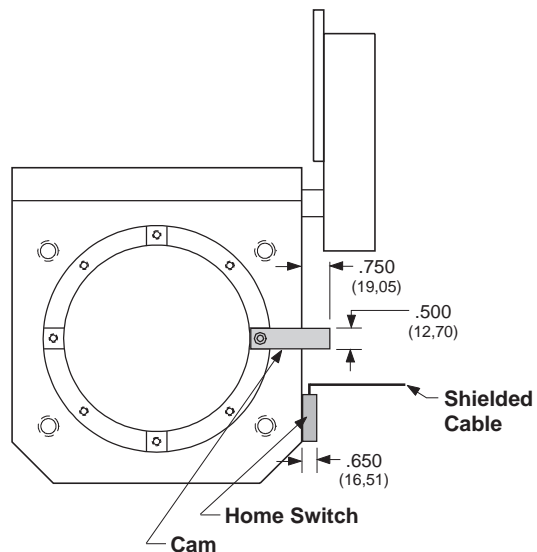

Mechanical Switches

Repeatability	: +/- 10 arc-sec
Electrical	: 5 amps @ 125 VAC 1 amp @ 85 VDC
Activation Style	: mechanical cam
Activation Area	: 0.5 inches (12,7 mm) of travel
Temperature Range	: - 25° C to + 85° C
Environment	: non wash down
Individual Switch Wiring	: none

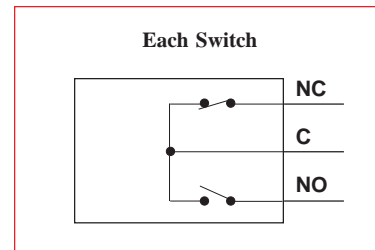

Standard *LINTECH* Wiring : from table,
(provided when switch option is ordered with any table) 10 foot (3 m) shielded cable,
6 conductor, 24 AWG, unterminated leads

400 Series

Wire Color	Description
Brown	HOME
Green	HOME Common
Silver	Shield

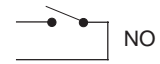

NO - Normally Open

Home Switch

Non-Contact Reed Switches

Repeatability	: +/- 100 arc-sec
Electrical	: 1.0 amps @ 125 VAC 0.5 amps @ 100 VDC
Activation Style	: magnetic
Activation Area	: 0.30 inches (7,62 mm) of travel
Temperature Range	: - 10° C to + 60° C
Environment	: non wash down
Individual Switch Wiring	: 12 inch (305 mm) leads

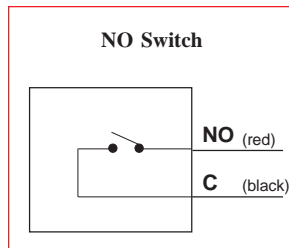

Standard *LINTECH* Wiring : from table,
(provided when switch option is ordered with any table) 10 foot (3 m) shielded cable, 6 conductor, 24 AWG, unterminated leads

300 Series

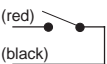
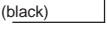
Pin #	Wire Color	Description
7	Brown	HOME 
8	Green	HOME Common 
3	Silver	Shield

Non-Contact Hall Effect Switches

Repeatability	: +/- 10 arc-sec
Electrical	: 5 - 24 VDC 15 mA - power input 25 mA max - signal
Actuation Style	: magnetic
Activation Area	: 0.32 inches (8,13 mm) of travel
Temperature Range	: - 10° C to + 60° C
Environment	: wash down
Individual Switch Wiring	: 12 inch (305 mm) leads

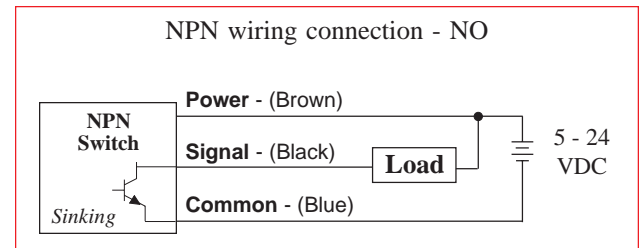

Standard *LINTECH* Wiring : from table,
(provided when switch option is ordered with any table) 10 foot (3 m) shielded cable; 9 conductor, 24 AWG, unterminated leads

300 Series

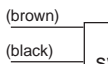
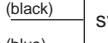
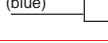
Pin #	Wire Color	Description
5	Orange	Home Power 
7	Yellow	Home 
8	Grey	Home Common 
3	Silver	Shield

NO - Normally Open