

150 Series Positioning Tables



G

Introduction	G-2
Ordering Guide	G-4
Specifications	G-5
Dimensions	G-6
Linear Bearing Load Capacity	G-10
Screw Travel Life	G-11
Thrust Capacity (axial load)	G-12
Table Deflection	G-13
Multiple Axis Configurations	G-14
EOT & Home Switches	G-15
Screw Options	G-18
Motor Couplings	G-24
Motor Mount Options	G-26
Power-off Electric Brakes	G-28
Linear & Rotary Encoders	G-29

Single or Multiple Axis

LINTECH's 150 series positioning tables offer precision performance and design flexibility for use in a wide variety of Motion Control applications.

- ❑ *Welding*
- ❑ *Test Stands*
- ❑ *Part Insertion*
- ❑ *Laser Positioning*
- ❑ *Liquid Dispensing*
- ❑ *Semiconductor Processing*
- ❑ *Gluing*
- ❑ *Pick & Place*
- ❑ *Part Scanning*
- ❑ *Inspection Stations*
- ❑ *General Automation*

Quality Construction

LINTECH's 150 series tables are designed with a low friction, preloaded, recirculating linear ball bearing system, which rides on a precision ground linear rails. The linear rails are mounted to a precision machined aluminum base, which offers a rigid support over the entire travel of the table's carriage. The load is mounted to a precision machined aluminum carriage, which has threaded stainless steel inserts for high strength and wear life. There are 40 different acme & ball screw options, that offer high efficiencies and long life at an economical price. These tables are designed to allow for numerous options. They include EOT & Home switches, linear & rotary encoders, power-off electric brakes, motor wrap packages and versatile mounting brackets for multiple axis applications.



Available Options

Acme Screws & Ball Screws

An assortment of acme screws and ball screws can be installed in the 150 series tables, providing solutions to load back driving, high duty cycle, high speed, extreme smoothness, and sensitive positioning applications.

Vertical Angle Brackets

Optional vertical angle brackets can be mounted directly to the top of various *LINTECH* positioning tables, thus providing for easy multiple axis configurations.

Waycovers

For operator protection, these tables can be fitted with a protective bellows. The entire length of the lead screw and linear bearing system will be covered.

End of Travel and Home Switches

The 150 series tables can be provided with end of travel (EOT) and home switches mounted and wired for each axis. Most position controllers can utilize the EOT switches to stop carriage motion when the extreme table travel has been reached in either direction. The home switch provides a known mechanical location on the table.

Linear and Rotary Encoders

Incremental encoders can be mounted to the table in order to provide positional data back to either a motion controller, or a digital display.

Motor Adapter Brackets

NEMA 23, NEMA 34, or any metric mount motor can be mounted to a 150 series positioning table with the use of adapter brackets.

Turcite Nut With Rolled Ball Screw

This solid polymer nut has no rolling elements in it, and performs very similar to an acme nut. It can provide smoother motion & less audible noise than most ball nuts, and is ideal for corrosive & vertical applications.

Other

The 150 series tables can accommodate **chrome plated linear bearings, rails, & screws** for corrosive environment applications, **power-off electric brakes** for load locking applications, **motor wrap packages** for space limited applications, and a **hand crank** for manually operated applications.

Standard Features - 150 Series

- ❑ Compact 6.750 inches (171 mm) wide by 2.625 inches (67 mm) tall
- ❑ Travel lengths from 6 inches (150 mm) to 62 inches (1570 mm)
- ❑ Threaded stainless steel inserts in carriage for load mounting
- ❑ 0° F to +185° F (-18° C to +85° C) operating temperature
- ❑ 2 rail, 2 & 4 bearing, 4 & 8 inch long carriages
- ❑ Recirculating linear ball bearing system
- ❑ Precision ground square rail design

150-WC0 Series



150-WC1 Series



Options - 150 Series

- ❑ Chrome plated linear bearings, rails and screws
- ❑ End of travel (EOT) and home switches wired
- ❑ AUTOCAD® drawings available upon request
- ❑ Adapter brackets for non-NEMA motors
- ❑ Linear and rotary incremental encoders
- ❑ NEMA 23 & 34 motor wrap packages
- ❑ NEMA 34 adapter bracket
- ❑ Power-off electric brakes
- ❑ Vertical angle bracket
- ❑ Turcite nut option
- ❑ Motor couplings
- ❑ Hand crank
- ❑ Ball screws:

Rolled - Non-preloaded & Preloaded Nuts:

- 0.625 inch diameter, 0.200 inch lead
- 0.625 inch diameter, 1.000 inch lead
- 0.750 inch diameter, 0.200 inch lead
- 0.750 inch diameter, 0.500 inch lead

Precision - Non-preloaded & Preloaded Nuts:

- 0.625 inch diameter, 0.200 inch lead
- 16 mm diameter, 5 mm lead
- 16 mm diameter, 10 mm lead
- 16 mm diameter, 16 mm lead
- 0.750 inch diameter, 0.200 inch lead
- 20 mm diameter, 5 mm lead
- 20 mm diameter, 20 mm lead

Ground - Preloaded Nuts Only:

- 0.625 inch diameter, 0.200 inch lead
- 16 mm diameter, 5 mm lead
- 16 mm diameter, 16 mm lead
- 0.750 inch diameter, 0.200 inch lead
- 0.750 inch diameter, 0.500 inch lead

- ❑ Acme screws:

Rolled - Non-preloaded & Preloaded Nuts:

- 0.625 inch diameter, 0.100 inch lead
- 0.625 inch diameter, 0.200 inch lead

15 **08** **06** - **WC1** - **1** - **S114** - **M02** - **C155** - **L01** - **E00** - **B00**

Table Series

Carriage Length

04 - 4 inches **08** - 8 inches

Travel Length (see pages G-6 & G-8)

06 - 6 to 62 inches

Waycovers

WC0 - with no waycovers **WC1** - with waycovers

Carriage Inserts (see pages G-7 & G-9)

1 - English mount **2** - Metric mount

Screw Options (see pages G-18 to G-23)

Rolled ball screws

- S005** - .625 x .200 NPL
- S006** - .625 x .200 PL
- S007** - .625 x .200 NPL(T)
- S008** - .625 x .200 PL(T)
- S009** - .625 x 1.000 NPL
- S010** - .625 x 1.000 PL
- S011** - .625 x 1.000 NPL(T)
- S012** - .625 x 1.000 PL(T)
- S013** - .750 x .200 NPL
- S014** - .750 x .200 PL
- S015** - .750 x .200 NPL(T)
- S016** - .750 x .200 PL(T)
- S017** - .750 x .500 NPL
- S018** - .750 x .500 PL
- S019** - .750 x .500 NPL(T)
- S020** - .750 x .500 PL(T)

Precision ball screws

- S114** - .625 x .200 NPL
- S115** - .625 x .200 PL
- S116** - 16 x 5 NPL
- S117** - 16 x 5 PL
- S118** - 16 x 10 NPL
- S119** - 16 x 10 PL
- S120** - 16 x 16 NPL
- S121** - 16 x 16 PL
- S122** - .750 x .200 NPL
- S123** - .750 x .200 PL
- S124** - 20 x 5 NPL
- S125** - 20 x 5 PL
- S128** - 20 x 20 NPL
- S129** - 20 x 20 PL

Ground ball screws

- S212** - .625 x .200 PL
- S213** - .625 x .500 PL
- S214** - 16 x 5 PL
- S215** - 16 x 16 PL
- S216** - .750 x .200 PL
- S217** - .750 x .500 PL

Rolled acme screws

- S300** - .625 x .100 NPL
- S301** - .625 x .100 PL
- S302** - .625 x .200 NPL
- S303** - .625 x .200 PL
- S999** - other

Motor Mount (see pages G-7 & G-9, G-26 to G-27)

- M00** - none
- M01** - hand crank
- M99** - other
- M02** - NEMA 23 mount (E)
- M03** - NEMA 23 mount (M)
- M04** - NEMA 34 mount (E)
- M05** - NEMA 34 mount (M)
- M06** - NEMA 23 (RH) wrap
- M07** - NEMA 23 (LH) wrap
- M08** - NEMA 34 (RH) wrap
- M09** - NEMA 34 (LH) wrap

Coupling Options (see pages G-24 to G-25)

- C000** - none
- C999** - other
- C025 to C029** - C100
- C048 to C055** - C125
- C130 to C134** - H100
- C155 to C164** - H131
- C407 to C413** - G100
- C435 to C444** - G126

Limit & Home Switches (see pages G-15 to G-17)

- | | | | | | | |
|--------------------------|---------------------|------------|------------|------------|------------|------------|
| L00 - no switches | | Mechanical | Reed | Hall | Prox (NPN) | Prox (PNP) |
| L99 - other | EOT & home switches | L01 | L04 | L07 | L10 | L13 |
| | EOT switches only | L02 | L05 | L08 | L11 | L14 |
| | home switch only | L03 | L06 | L09 | L12 | L15 |

Encoder Options (see page G-29)

- E00** - none
- E01** - rotary (500 lines/rev)
- E02** - rotary (1000 lines/rev)
- E03** - rotary (1270 lines/rev)
- E10** - linear (2500 lines/inch)
- E11** - linear (250 lines/mm)
- E99** - other

Power-off Brakes (see page G-28)

- B00** - none
- B01** - 24 VDC
- B02** - 90 VDC
- B99** - other

(E) - English Interface (NPL) - Non Preloaded
 (LH) - Left Hand (PL) - Preloaded
 (M) - Metric Interface (RH) - Right Hand
 (T) - Turcite Nut

Specifications subject to change without notice

Specifications

Made in the U.S.A.

Load Capacities		4 inch (2 bearing) Carriage	8 inch (4 bearing) Carriage
Dynamic Horizontal	2 million inches (50 km) of travel	1,900 lbs (862 kg)	3,800 lbs (1724 kg)
Dynamic Horizontal	50 million inches (1270 km) of travel	645 lbs (293 kg)	1,290 lbs (585 kg)
Static Horizontal		3,400 lbs (1542 kg)	6,800 lbs (3084 kg)
Dynamic Roll Moment	2 million inches (50 km) of travel	285 ft-lbs (386 N-m)	575 ft-lbs (780 N-m)
Dynamic Roll Moment	50 million inches (1270 km) of travel	98 ft-lbs (133 N-m)	196 ft-lbs (266 N-m)
Static Roll Moment		515 ft-lbs (698 N-m)	1,030 ft-lbs (1396 N-m)
Dyn. Pitch & Yaw Moment	2 million inches (50 km) of travel	56 ft-lbs (76 N-m)	700 ft-lbs (949 N-m)
Dyn. Pitch & Yaw Moment	50 million inches (1270 km) of travel	19 ft-lbs (26 N-m)	239 ft-lbs (324 N-m)
Static Pitch & Yaw Moment		100 ft-lbs (136 N-m)	1,255 ft-lbs (1702 N-m)
Each Bearing Dyn. Capacity	2 million inches (50 km) of travel	950 lbs (431 kg)	950 lbs (431 kg)
Each Bearing Dyn. Capacity	50 million inches (1270 km) of travel	323 lbs (147 kg)	323 lbs (147 kg)
Each Bearing Static Load Capacity		1,700 lbs (771 kg)	1,700 lbs (771 kg)
Thrust Force Capacity	10 million screw revolutions	895 lbs (406 kg)	895 lbs (406 kg)
Thrust Force Capacity	500 million screw revolutions	240 lbs (109 kg)	240 lbs (109 kg)
Maximum Acceleration		386 in/sec ² (9,8 m/sec ²)	772 in/sec ² (19,6 m/sec ²)
d₁	Center to center distance (spread) between the two rails	4.300 in (109,2 mm)	4.300 in (109,2 mm)
d₂	Center to center distance (spacing) of the bearings on a single rail	-	4.900 in (124,5 mm)
d_r	Center distance of the bearing to top of carriage plate surface	1.250 in (31,8 mm)	1.250 in (31,8 mm)

Other	For 4 inch (2 bearing) & 8 inch (4 bearing) Carriages
Table Material	Base, Carriage, End Plates, & Cover Plate option - 6061 anodized aluminum
Linear Rail Material	Case Hardened Steel
Screw Material (see pages G-18 to G-23)	Acme Screw - Stainless Steel
Screw Material (see pages G-18 to G-23)	Rolled Ball, Precision Ball, & Ground Ball - Case Hardened Steel
Straightness	< 0.00004 in/in (< 1,02 microns/25mm)
Flatness	< 0.00004 in/in (< 1,02 microns/25mm)
Orthogonality (multi-axis systems)	< 15 arc-seconds
Friction Coefficient	< 0.01
Motor Mount	NEMA 23 & 34 Mounts, Metric Mounts, Motor Wraps, and Hand Crank Option
Coupling	Three (3) different styles available
Waycover Material	Hypilon Polyester Bellows firmly mounted to carriage & end plates

G

Dimensions & Specifications

- Without Waycovers -

Made in the U.S.A.

Model Number	Travel Length inches (mm)	Table Dimensions inches (mm)		Mounting Dimensions inches (mm)			Screw Length inches (mm)	Table ⁽¹⁾ Weight lbs (kg)
		A	B	C	D	M		
150408-WC0	8 (200)	13.62 (345,9)	16.12 (409,4)	1.190 (30,2)	3	8	15.28 (388)	21.9 (9,9)
150416-WC0	16 (400)	21.25 (539,7)	23.75 (603,2)	1.250 (31,7)	5	12	22.91 (582)	28.4 (12,9)
150423-WC0	23 (580)	28.75 (730,2)	31.25 (793,7)	1.250 (31,7)	7	16	30.41 (772)	33.9 (15,4)
150431-WC0	31 (785)	36.50 (927,1)	39.00 (990,6)	1.380 (35,1)	9	20	38.16 (969)	40.3 (18,3)
150439-WC0	39 (990)	44.25 (1123,9)	46.25 (1174,7)	1.500 (38,1)	11	24	45.91 (1166)	46.8 (21,2)
150446-WC0	46 (1165)	51.75 (1314,4)	54.25 (1377,9)	1.500 (38,1)	13	28	53.41 (1357)	53.3 (24,2)
150462-WC0	62 (1570)	67.25 (1708,1)	69.75 (1771,6)	1.750 (44,4)	17	36	68.91 (1750)	66.2 (30,0)
150808-WC0	8 (200)	17.62 (447,5)	20.12 (511,0)	3.190 (81,0)	3	8	19.28 (490)	24.9 (11,3)
150816-WC0	16 (400)	25.25 (641,3)	27.75 (704,8)	3.250 (82,5)	5	12	26.91 (684)	31.4 (15,0)
150823-WC0	23 (580)	32.75 (831,8)	35.25 (895,3)	3.250 (82,5)	7	16	34.41 (874)	37.9 (17,2)
150831-WC0	31 (785)	40.50 (1028,7)	43.00 (1092,2)	3.380 (85,8)	9	20	42.16 (1071)	44.3 (20,1)
150839-WC0	39 (990)	48.25 (1225,5)	50.75 (1289,0)	3.500 (88,9)	11	24	49.91 (1268)	50.8 (23,1)
150846-WC0	46 (1165)	55.75 (1416,0)	58.25 (1479,5)	1.625 (41,1)	14	30	57.41 (1458)	57.3 (26,0)
150862-WC0	62 (1570)	71.25 (1809,7)	73.75 (1873,2)	1.250 (31,7)	18	38	72.91 (1852)	70.2 (31,8)

- 04 = 4 inch (101,6 mm) carriage length; 2 bearings; carriage weight = 4.0 lbs. (1,81 kg)
- 08 = 8 inch (203,2 mm) carriage length; 4 bearings; carriage weight = 7.0 lbs. (3,17 kg)

Footnotes:

(1) Weight shown is with a 0.625 inch (16 mm) diameter screw, a NEMA 23 motor mount [0.34 lbs (0,16 kg)], and a C100 style [0.09 lbs (0,04 kg)] coupling. When using a 0.750 inch (20 mm) diameter screw add 0.042 lbs per inch (0,00075 kg per mm) of screw length for a given model number.

Dimensions

- Without Waycovers -

Made in the U.S.A.

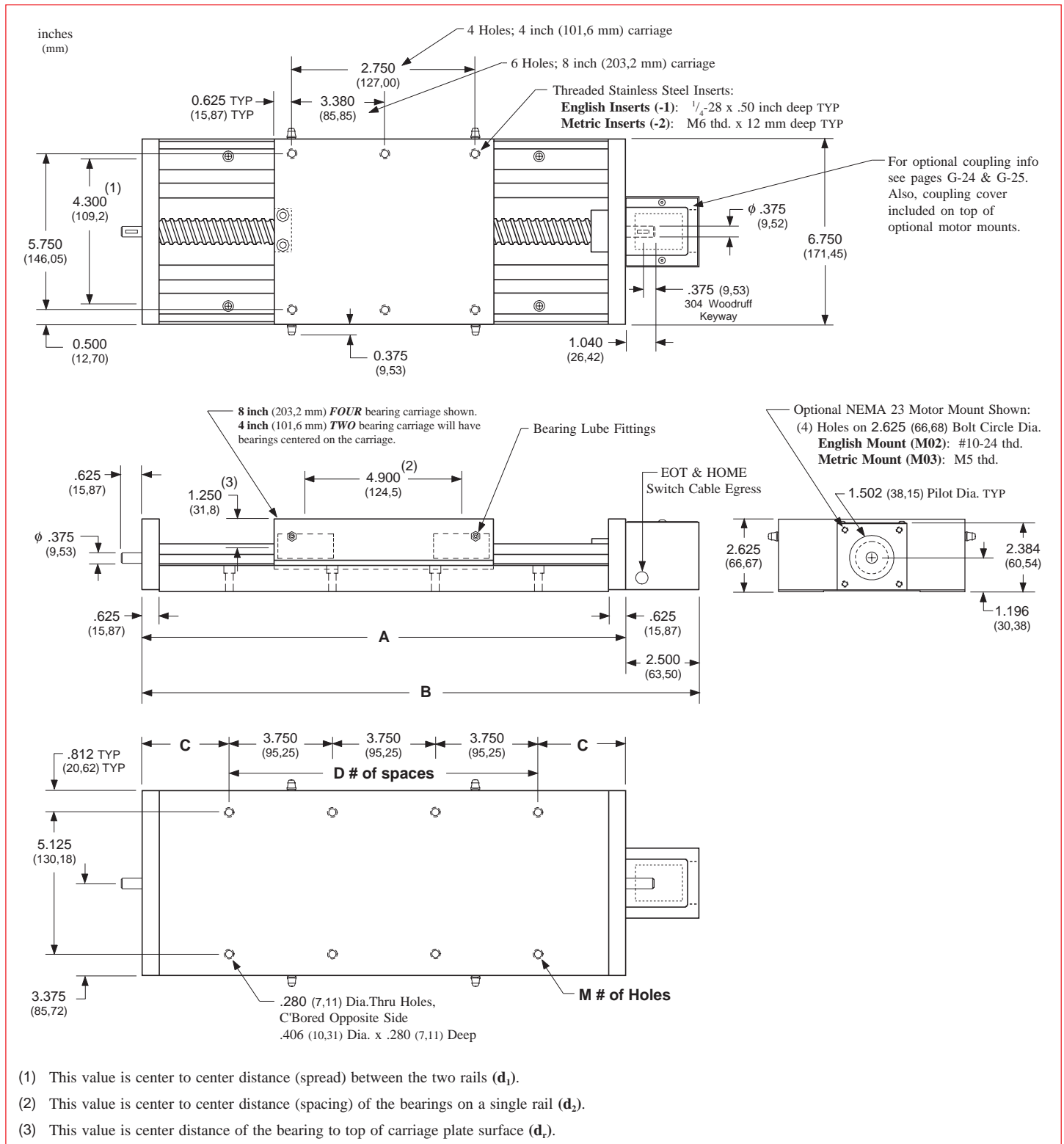

Note: Any 150 series table can be mounted on top of any second 150 series, in order to create X-Y multiple axis configurations. The carriage's threaded stainless steel insert hole pattern DOES NOT exactly match the base mounting hole pattern on each table, therefore machining of the bottom axis carriage plate is required. Contact *LINTECH*.

Dimensions & Specifications

- With Waycovers -

Made in the U.S.A.

Model Number	Travel Length inches (mm)	Table Dimensions inches (mm)		Mounting Dimensions inches (mm)			Screw Length inches (mm)	Table ⁽¹⁾ Weight lbs (kg)
		A	B	C	D	M		
150406-WC1	6 (150)	13.62 (345,9)	16.12 (409,4)	1.190 (30,2)	3	8	15.28 (388)	23.0 (10,4)
150412-WC1	12 (300)	21.25 (539,7)	23.75 (603,2)	1.250 (31,7)	5	12	22.91 (582)	30.0 (13,6)
150418-WC1	18 (455)	28.75 (730,2)	31.25 (793,7)	1.250 (31,7)	7	16	30.41 (772)	36.0 (16,3)
150424-WC1	24 (600)	36.50 (927,1)	39.00 (990,6)	1.380 (35,1)	9	20	38.16 (969)	43.0 (19,5)
150430-WC1	30 (760)	44.25 (1123,9)	46.25 (1174,7)	1.500 (38,1)	11	24	45.91 (1166)	50.0 (22,7)
150436-WC1	36 (910)	51.75 (1314,4)	54.25 (1377,9)	1.500 (38,1)	13	28	53.41 (1357)	57.0 (25,8)
150448-WC1	48 (1215)	67.25 (1708,1)	69.75 (1771,6)	1.750 (44,4)	17	36	68.91 (1750)	71.0 (32,2)
150806-WC1	6 (150)	17.62 (447,5)	20.12 (511,0)	3.190 (81,0)	3	8	19.28 (490)	26.0 (11,8)
150812-WC1	12 (300)	25.25 (641,3)	27.75 (704,8)	3.250 (82,5)	5	12	26.91 (684)	33.0 (15,0)
150818-WC1	18 (455)	32.75 (831,8)	35.25 (895,3)	3.250 (82,5)	7	16	34.41 (874)	40.0 (18,1)
150824-WC1	24 (600)	40.50 (1028,7)	43.00 (1092,2)	3.380 (85,8)	9	20	42.16 (1071)	47.0 (21,3)
150830-WC1	30 (760)	48.25 (1225,5)	50.75 (1289,0)	3.500 (88,9)	11	24	49.91 (1268)	54.0 (24,5)
150836-WC1	36 (910)	55.75 (1416,0)	58.25 (1479,5)	1.625 (41,1)	14	30	57.41 (1458)	61.0 (27,7)
150848-WC1	48 (1215)	71.25 (1809,7)	73.75 (1873,2)	1.250 (31,7)	18	38	72.91 (1852)	75.0 (34,0)

- 04 = 4 inch (101,6 mm) carriage length; 2 bearings; carriage weight = 4.0 lbs. (1,81 kg)
- 08 = 8 inch (203,2 mm) carriage length; 4 bearings; carriage weight = 7.0 lbs. (3,17 kg)

Footnotes:

(1) Weight shown is with a 0.625 inch (16 mm) diameter screw, a NEMA 23 motor mount [0.34 lbs (0,16 kg)], and a C100 style [0.09 lbs (0,04 kg)] coupling. When using a 0.750 inch (20 mm) diameter screw add 0.042 lbs per inch (0,00075 kg per mm) of screw length for a given model number.

Dimensions

- With Waycovers -

Made in the U.S.A.

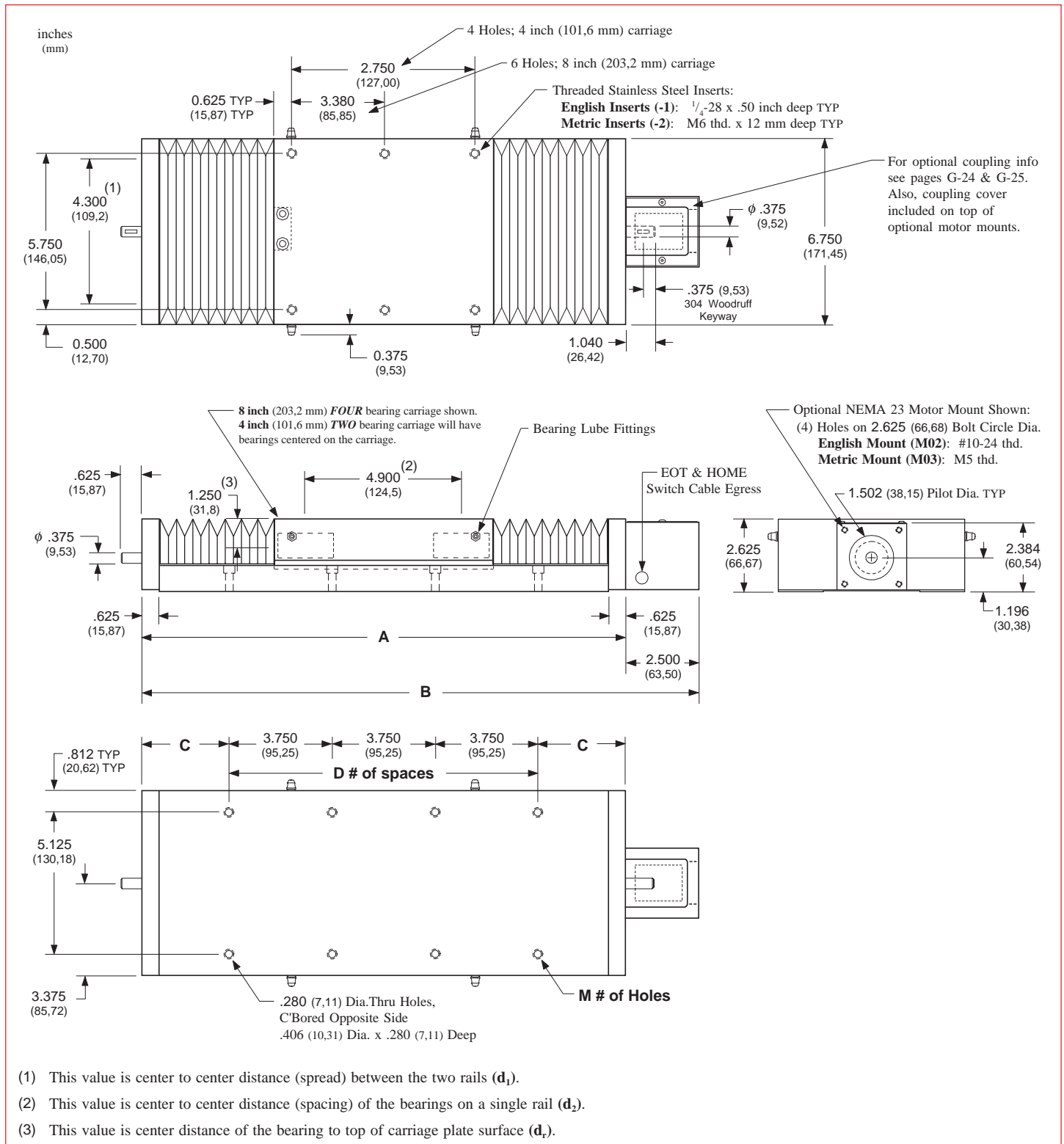

Note: Any 150 series table can be mounted on top of any second 150 series, in order to create X-Y multiple axis configurations. The carriage's threaded stainless steel insert hole pattern DOES NOT exactly match the base mounting hole pattern on each table, therefore machining of the bottom axis carriage plate is required. Contact *LINTECH*.

Linear Bearing Load Capacities

The following equation, and graphs, can be used to help determine the linear bearing life, and load capacity, of a 150 series positioning table.

$$L = \left[\frac{R}{F \times S} \right]^3 \times B$$

- L** = calculated travel life (millions of inches or Km)
- R** = rated dynamic load capacity of carriage (or each bearing) at 2 million inches of travel or 50 Km
- F** = user applied load
- S** = safety factor (1 to 8)
- B** = either 2 (for millions of inches) or 50 (for Km)

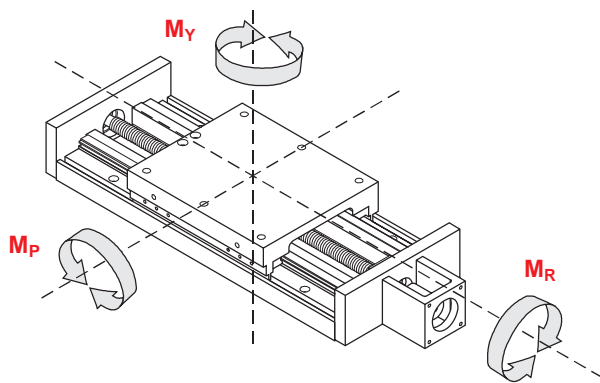

Dynamic Horizontal Load Capacity

Load Centered on Carriage

travel life		2 Bearing		4 Bearing	
millions of inches	(Km)	lbs	(kg)	lbs	(kg)
2	(50)	1,900	(862)	3,800	(1724)
50	(1270)	645	(293)	1,290	(585)
100	(2540)	510	(231)	1,020	(463)

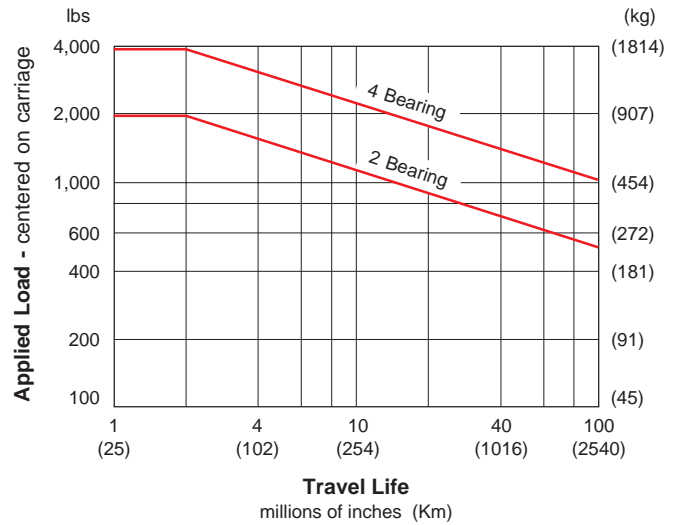

Dynamic Moment Load (M_R) Capacity

Load applied away from Carriage Center

travel life		2 Bearing		4 Bearing	
millions of inches	(Km)	ft-lbs	(N-m)	ft-lbs	(N-m)
2	(50)	285	(386)	575	(780)
50	(1270)	98	(133)	196	(266)
100	(2540)	77	(104)	155	(210)

Ratings are based on d₃ = 12 inches (305 mm) & d₄ = 0

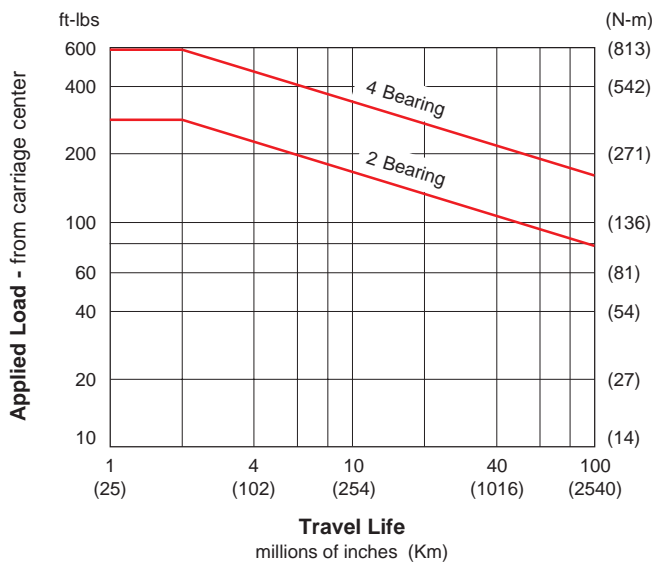

Dynamic Moment Load (M_P & M_Y) Capacity

Load applied away from Carriage Center

travel life		2 Bearing		4 Bearing	
millions of inches	(Km)	ft-lbs	(N-m)	ft-lbs	(N-m)
2	(50)	56	(76)	700	(949)
50	(1270)	19	(26)	239	(324)
100	(2540)	15	(20)	190	(258)

Ratings are based on d₃ = 0 & d₄ = 12 inches (305 mm)

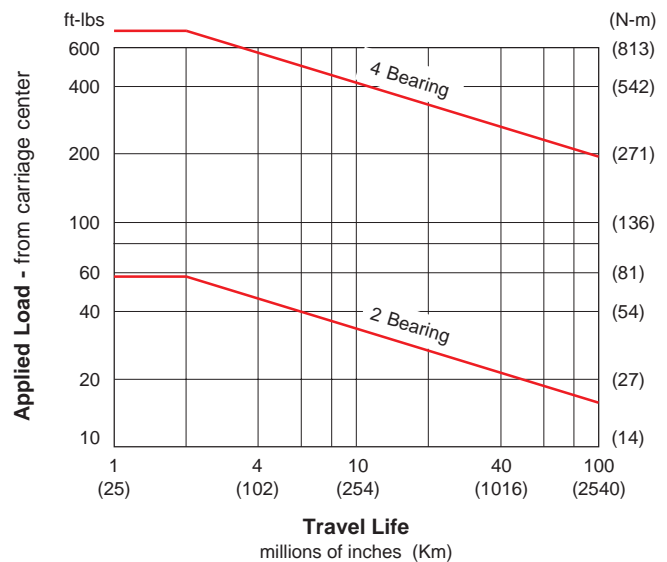

Specifications subject to change without notice

Screw Travel Life

The life of an acme or ball screw can be estimated by evaluating the load applied to the nut. The applied load "as seen by the screw nut" depends upon the table orientation. Typically, the extra force acting upon the screw nut during the acceleration interval is offset by a reduction in force during the deceleration interval. Therefore, evaluating the life of the screw nut at a constant speed is adequate. The life of the screw nut may not be the limiting element for a given application. See page G-12 for load/life capacity of the screw end support bearings.

Horizontal Application

$$F = (W \times \mu) + E$$

Vertical Application

$$F = W + E$$

$$L = \left[\frac{R}{F \times S} \right]^3 \times B$$

- B** = either 1 (for millions of inches) or 25 (for Km)
- E** = externally applied extra forces
- F** = applied axial load (as seen by screw nut)
- L** = calculated travel life (millions of inches or Km)
- R** = rated dynamic load capacity of screw nut at 1 million inches of travel or 25 Km (see pages G-21 to G-23)
- S** = safety factor (1 to 8)
- W** = user mounted load weight to carriage
- μ** = coefficient of friction for linear bearing system (0.01)

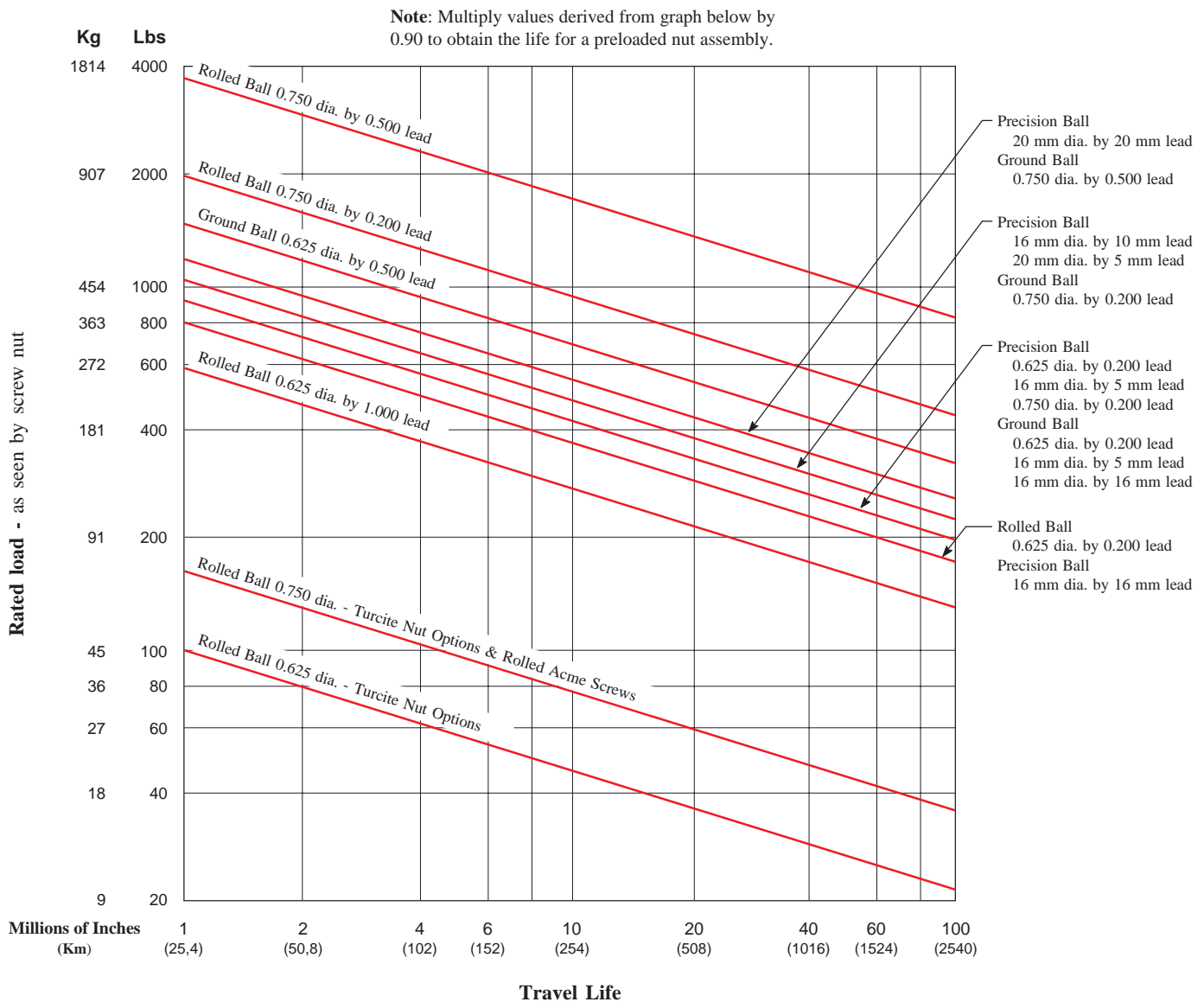

Specifications subject to change without notice

Thrust Capacity (axial load)

The life of the screw end support bearings can be estimated by evaluating the applied axial (thrust) load. The applied load "as seen by the bearings" depends upon the table orientation. Typically, the extra force acting upon the bearings during the acceleration interval is offset by a reduction in force during the deceleration interval. Therefore, evaluating the life of the bearings at a constant speed is adequate. The life of the screw end support bearings may not be the limiting element for a given application. See page G-11 for load/life capacity of acme and ball screw nuts.

$$L = \left[\frac{R}{F \times S} \right]^3 \times B$$

- B** = 2 (for millions of revolutions)
- E** = externally applied extra forces
- F** = applied axial load (*as seen by the bearings*)
- L** = calculated life (millions of revolutions)
- R** = dynamic load capacity of bearings at 2 million screw revolutions (see below)
- S** = safety factor (1 to 8)
- W** = user mounted load weight to carriage
- μ** = coefficient of friction for linear bearing system (0.01)

Horizontal Application

$$F = (W \times \mu) + E$$

Vertical Application

$$F = W + E$$

Screw End Supports		Number of Screw Revolutions millions of screw revolutions						
		Static	1	2	10	50	100	500
Thrust Capacity	lbs (kg)	1,725 (782)	1,725 (782)	1,530 (694)	895 (406)	525 (238)	415 (188)	240 (109)

Note: Multiply screw revolutions by the screw lead in order to convert to inches (or mm) traveled by the nut.

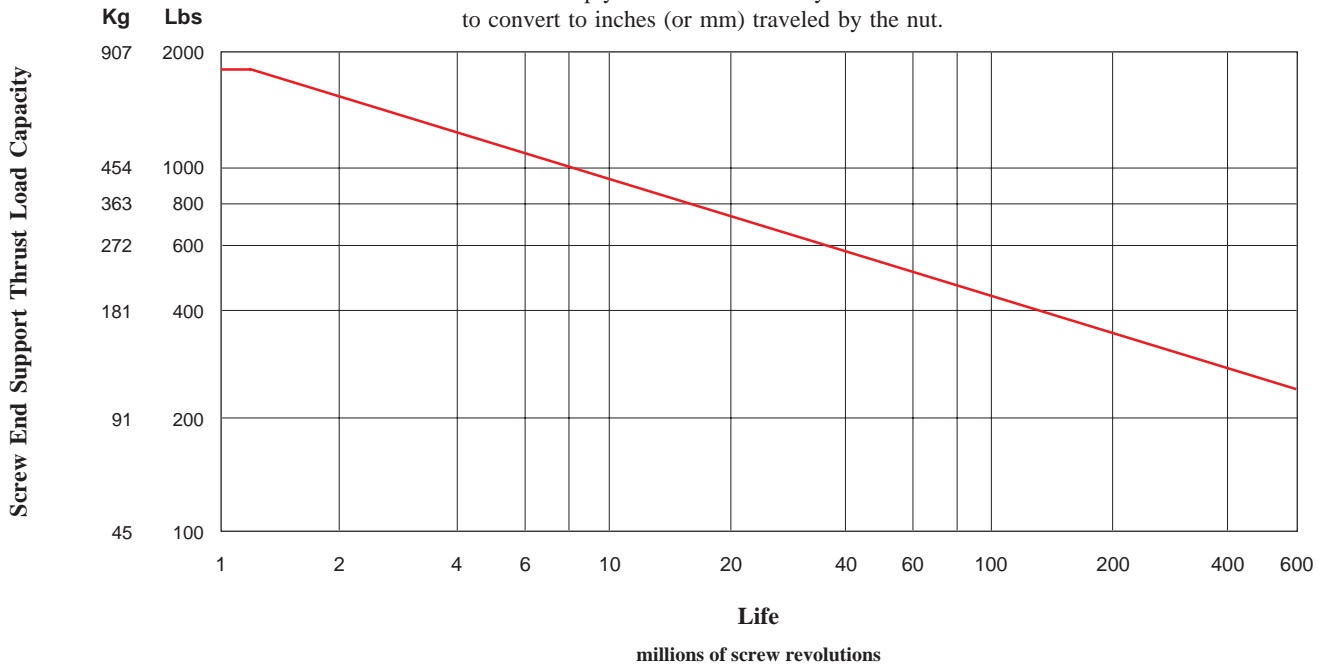

Moment of Inertia Values

The "moment of inertia" of an object is a gauge of the strength of that object to resist deflecting when used in an application or orientation where deflection might occur. The higher an I value relates to a lower amount of deflection.

$I = 0.63 \text{ in}^4 \text{ (} 2.62 \times 10^5 \text{ mm}^4\text{)}$

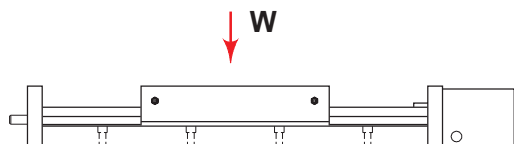

$I = 23.5 \text{ in}^4 \text{ (} 97.8 \times 10^5 \text{ mm}^4\text{)}$

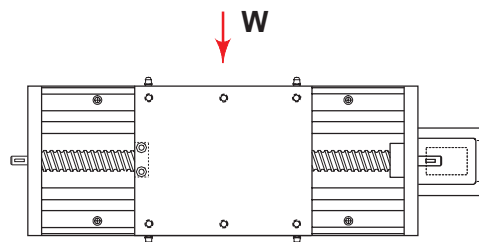

Multi-Axis Configurations

LINTECH can provide various adapter plates, and vertical adapter brackets, to facilitate the construction of X-Y, X-Z, and X-Y-Z multiple axis configurations. There are literally hundreds of different possible configurations available. See below for some of the more common systems. *LINTECH* has a great deal of experience in dealing with multiple axis configurations. Sometimes different standard table series can be mounted together to form a custom system. Other times, a complete custom assembly is created, due to the application details. Contact *LINTECH* for more information.

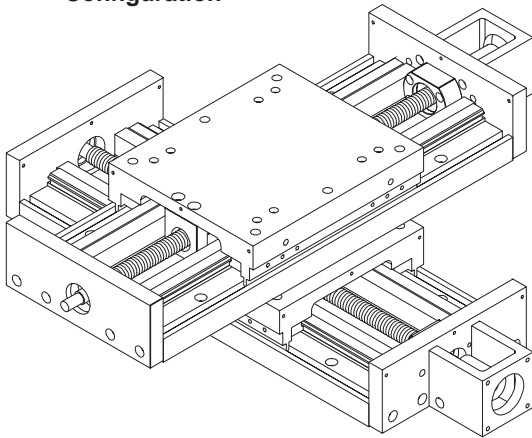
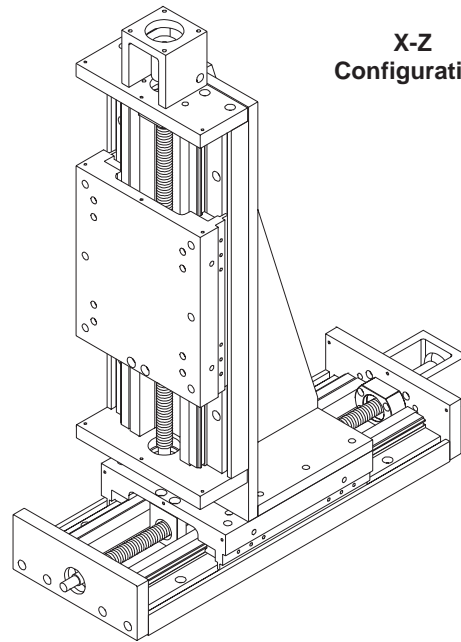
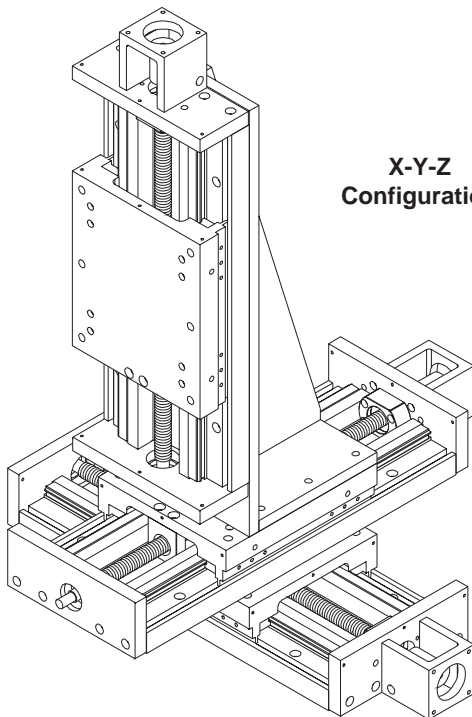
**X-Y
Configuration****X-Z
Configuration****X-Y-Z
Configuration**

End of Travel (EOT) Switches & Home Switch

LINTECH provides several options for EOT & home switches. One style uses mechanically actuated switches, while other styles use "non-contact" versions. When ordered with a *LINTECH* 150 series table, each switch is mounted to the base of the table, while the actuating cams are mounted to the carriage assembly. Each switch is mounted to a plate that allows for a 0.625 inch (16 mm) adjustment range. The switches are pre-wired by *LINTECH* for easy interfacing to the users Motion Controller.

End of Travel (EOT) Switches

End of travel (EOT) switches can be utilized by a motion controller to stop carriage motion, thereby preventing any damage to personnel, table carriage, or user mounted load if the extreme end of travel has been reached by the carriage. There are two EOT switches mounted to the side of the table, one on each end. The CCW switch is mounted at the motor mount end, while the CW switch is located at the opposite end of the table. *LINTECH* provides normally closed (NC) end of travel switches. This provides for a power-off fail safe system, where the position controller can detect broken wires. *It is highly recommended that any positioning table used with a position controller, should have end of travel switches installed for protection of personnel, table carriage, and user mounted load.*

Home Switch

The home switch can be utilized by a motion controller as a known fixed mechanical location on the positioning table. The switch is located on the opposite side of the EOT switches, at the motor mount end, and is a normally open (NO) switch.

Switch Locations

The following diagram shows the locations of the switches when ordered from *LINTECH*.

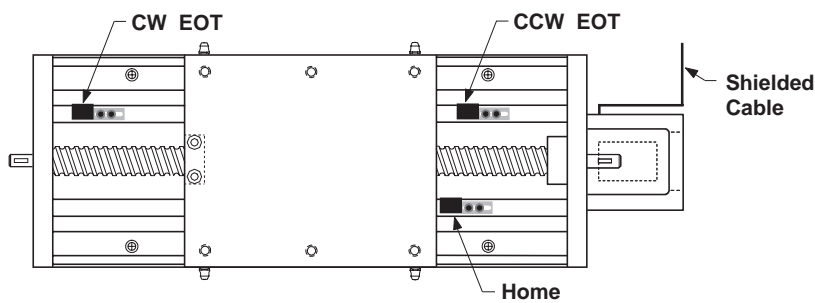

Note: For the 150-WC0 series, EOT switches are normally located 0.125 inches (3 mm) inward from the maximum travel hard stops. Thus, reducing overall system travel by 0.25 inches (6 mm) from listed table travel for each model #. For the 150-WC1 series there is NO reduction of listed travel length when using EOT switches.

Note: Each switch bracket has a 0.625 inch (16 mm) adjustment range

Switch Type	Cost	Repeatability inches (microns)	Actuated	Power Supply Required	Activation Area inches (mm)	Comments
mechanical	least expensive	+/- 0.0002 (5)	mechanical	No	1.75 (44,45)	for most applications
reed	slightly more	+/- 0.0020 (50)	magnetic	No	0.30 (7,62)	for non-contact & low repeatable applications
hall effect	medium priced	+/- 0.0002 (5)	magnetic	Yes	0.32 (8,13)	for non-contact and wash down applications
proximity	most expensive	+/- 0.0002 (5)	non-magnetic	Yes	1.75 (44,45)	for non-contact, high speed, & wash down applications

Note: The repeatability of any switch is dependent upon several factors: carriage speed, accel rate, load weight, switch style, and the position controller. *LINTECH*'s ratings are based upon a carriage speed of 0.5 inches/sec (12.7 mm/sec) and a no load condition.

End of Travel (EOT) Switches & Home Switch

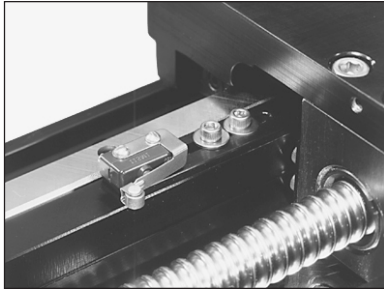
Mechanical Switches

Repeatability	: +/- 0.0002 inch (5 microns)
Electrical	: 5 amps @ 125 VAC 1 amp @ 85 VDC
Activation Style	: mechanical cam
Activation Area	: 1.75 inches (44,45 mm) of travel
Temperature Range	: - 25° C to + 85° C
Environment	: non wash down
Added Table Width	: none
Individual Switch Wiring	: none

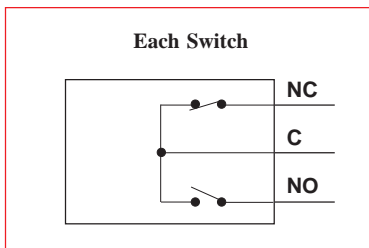

Standard *LINTECH* Wiring : from table end plate,
(provided when switch option is 10 foot (3 m) shielded cable,
ordered with any table) 6 conductor, 24 AWG,
underterminated leads

Wire Color	Description	
Black	CW EOT	NC
Blue	CW Common	
Red	CCW EOT	NC
White	CCW Common	
Brown	HOME	NO
Green	HOME Common	
Silver	Shield	

Note: Hermetically sealed mechanical switches can be ordered as an option. This may be desired for "wash down" applications. Contact *LINTECH*.

Specifications subject to change without notice

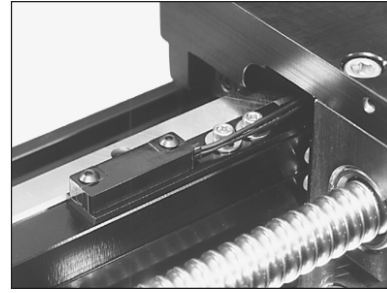
Non-Contact Reed Switches

Repeatability	: +/- 0.0020 inch (50 microns)
Electrical	: 1.0 amps @ 125 VAC 0.5 amps @ 100 VDC
Activation Style	: magnetic
Activation Area	: 0.30 inches (7,62 mm) of travel
Temperature Range	: - 10° C to + 60° C
Environment	: non wash down
Added Table Width	: none
Individual Switch Wiring	: 12 inch (305 mm) leads

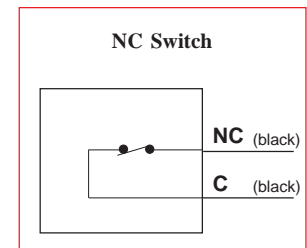
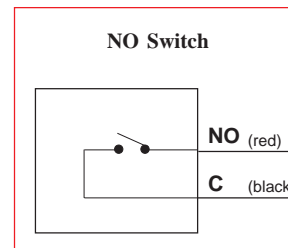

Standard *LINTECH* Wiring : from table end plate,
(provided when switch option is 10 foot (3 m) shielded cable,
ordered with any table) 6 conductor, 24 AWG,
underterminated leads

Wire Color	Description	
Black	CW EOT	NC
Blue	CW Common	
Red	CCW EOT	NC
White	CCW Common	
Brown	HOME	NO
Green	HOME Common	
Silver	Shield	

CW - Clockwise
CCW - Counter Clockwise
EOT - End of Travel
NC - Normally Closed
NO - Normally Open

End of Travel (EOT) Switches & Home Switch

Non-Contact Hall Effect Switches

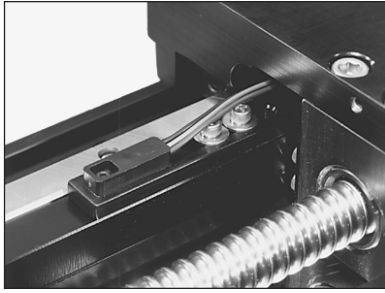

Repeatability	: +/- 0.0002 inch (5 microns)
Electrical	: 5 - 24 VDC 15 mA - power input 25 mA max - signal
Actuation Style	: magnetic
Activation Area	: 0.32 inches (8,13 mm) of travel
Temperature Range	: - 10° C to + 60° C
Environment	: wash down
Added Table Width	: none
Individual Switch Wiring	: 12 inch (305 mm) leads

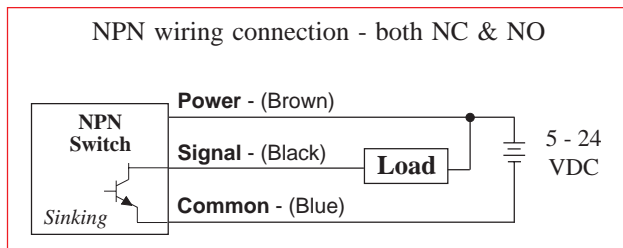

Standard *LINTECH* Wiring : from table end plate,
(provided when switch option is ordered with any table) 10 foot (3 m) shielded cable;
9 conductor, 24 AWG, unterminated leads

Wire Color	Description		
Brown	CW Power	(brown)	switch NC
Black	CW EOT	(black)	
Blue	CW Common	(blue)	
Red	CCW Power	(brown)	switch NC
White	CCW EOT	(black)	
Green	CCW Common	(blue)	
Orange	Home Power	(brown)	switch NO
Yellow	Home	(black)	
Grey	Home Common	(blue)	
Silver	Shield		

Non-Contact Proximity Switches

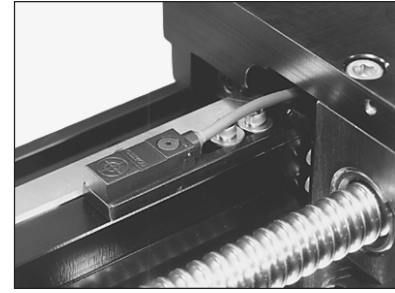

Repeatability	: +/- 0.0002 inch (5 microns)
Electrical	: 10 - 28 VDC 15 mA - power input 100 mA max - signal
Actuation Style	: non-magnetic cam
Activation Area	: 1.75 inches (44,45 mm) of travel
Temperature Range	: - 25° C to + 75° C
Environment	: IEC IP67 wash down
Added Table Width	: none
Individual Switch Wiring	: 6.5 foot (2 m) cable for NPN 3.3 foot (1 m) cable for PNP

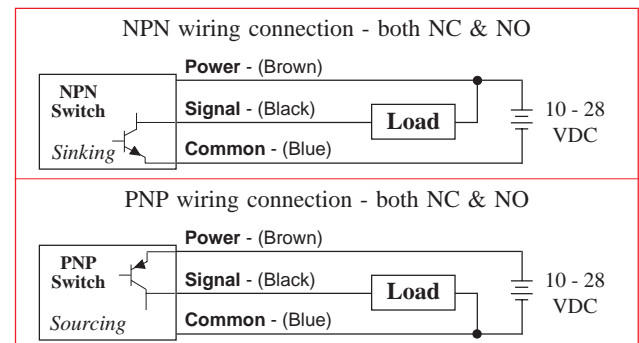

Standard *LINTECH* Wiring : from table end plate,
(provided when switch option is ordered with any table) 10 foot (3 m) shielded cable;
9 conductor, 24 AWG, unterminated leads

Wire Color	Description		
Brown	CW Power	(brown)	switch NC
Black	CW EOT	(black)	
Blue	CW Common	(blue)	
Red	CCW Power	(brown)	switch NC
White	CCW EOT	(black)	
Green	CCW Common	(blue)	
Orange	Home Power	(brown)	switch NO
Yellow	Home	(black)	
Grey	Home Common	(blue)	
Silver	Shield		

Specifications subject to change without notice

Screws - Acme & Ball

Acme screws use a turcite (polymer), or bronze nut. The nut threads ride in the matching acme screw threads, much like the ordinary nut and bolt system. This produces a higher friction (lower efficiency) system than a ball screw assembly, since there are no rolling elements between the nut and the acme screw threads. For applications requiring low speeds, noise and duty cycles, an acme screw works fine. Also, an acme screw is a good choice for most vertical applications, as it typically prevents back driving of the attached load.

Ball screws are the screw of choice for high duty cycle, high speed, and long life applications. The 150 series tables can be fitted with an assortment of ball screws. The ball screw nut uses one or more circuits of recirculating steel balls which roll between the nut and ball screw grooves, providing an efficient low friction system. Using a higher

lead ball screw (for example a 0.500 inch lead instead of a 0.200 inch lead) will offer greater carriage speed for applications requiring rapid traverse, or fast, short incremental moves. Low wear and long life are key features of a ball screw system.

LINTECH provides three different ball screw configurations. The rolled ball screw system utilizes a tapped nut with a standard accuracy grade rolled screw. The precision ball screw system utilizes a ground nut with a higher accuracy grade rolled screw. The ground ball screw system utilizes a ground nut with a high accuracy precision ground screw.

Some screws are available with preloaded nuts. The preloaded nut assembly offers high *bidirectional* repeatability by eliminating backlash.

Consideration	Acme Screw	Ball Screws			Comments
		Rolled	Precision	Ground	
Audible noise	least audible noise	most audible noise	less audible noise than rolled screw	less audible noise than precision screw	Acme: no rolling elements provide for quiet operation. Ball: recirculating balls in nut assembly transmit audible noise during motion; due to more accurate machining procedures - precision & ground ball screws are quieter than rolled ball screws.
Back Driving Loads	may prevent back driving	can easily back drive a load	can easily back drive a load	can easily back drive a load	Acme: good for light loads & vertical applications. Ball: recirculating balls in nut assembly produce a low friction system; vertical applications may require a brake to hold the load when no power is applied to the motor.
Backlash non-preloaded nut	will increase with wear	constant	constant	constant	Acme: preloaded nut assembly eliminates backlash. Ball: preloaded nut assembly eliminates backlash.
Duty Cycle	low to medium (< 50 %)	high (100 %)	high (100 %)	high (100 %)	Acme: low duty cycle due to high sliding friction. Ball: high duty cycle due to recirculating balls in nut assembly - high efficiency & low friction system.
Life	shorter due to higher friction	long	long	long	Acme: mechanical wear related to duty cycle, load & speed. Ball: minimal wear if operated in proper environment, within load specifications, and periodically lubricated.
Relative - Cost	slightly more than rolled ball	least expensive	slightly more than rolled ball	most expensive	Acme: a little more expensive than the rolled ball screw. Ball: due to more accurate manufacturing procedures precision rolled & ground ball screws are more expensive.
Screw Efficiency	low 40 % -Acme 60 % -Turcite	high (90 %)	high (90 %)	high (90 %)	Acme: low efficiency due to high sliding friction. Ball: high efficiency due to recirculating balls in nut assembly - low friction system.
Smoothness	can be smooth	least smooth	medium smoothness	smoothest	Acme: due to friction can start/stop at very low speeds. Ball: smoothness is constant through a wide speed range; due to more accurate manufacturing procedures precision rolled & ground ball screws are smoother than rolled ball screws.
Speeds	low	high	high	high	Acme: high friction can causes excess heat & wear at high speeds. Ball: recirculating balls in nut provide for a high speed system due to low friction & high efficiency.

Screws - Acme & Ball

150-WC0 series		150-WC1 series		Maximum Safe Table Operating Speed ⁽¹⁾ in/sec (mm/sec)						
Model Number	Travel Length inches (mm)	Model Number	Travel Length inches (mm)	Screw						
				0.625 dia. 0.100 lead	0.625 dia. 0.200 lead	0.625 dia. 0.500 lead	0.625 dia. 1.000 lead	16 mm dia. 5 mm lead	16 mm dia. 10 mm lead	16 mm dia. 16 mm lead
150408	8 (200)	150406	6 (150)	5.0 (127)	10.0 (254)	25.0 (635)	50.0 (1270)	9.8 (249)	19.7 (500)	31.5 (800)
150416	16 (400)	150412	12 (300)	5.0 (127)	10.0 (254)	25.0 (635)	50.0 (1270)	9.8 (249)	19.7 (500)	31.5 (800)
150423	23 (580)	150418	18 (455)	4.5 (114)	9.0 (229)	22.4 (569)	44.9 (1140)	8.8 (224)	17.5 (444)	28.0 (711)
150431	31 (785)	150424	24 (600)	2.8 (71)	5.6 (142)	13.9 (353)	27.9 (709)	5.4 (137)	10.8 (274)	17.4 (442)
150439	39 (990)	150430	30 (760)	1.9 (48)	3.8 (97)	9.5 (241)	19.0 (483)	3.7 (94)	7.4 (188)	11.8 (300)
150446	46 (1165)	150436	36 (910)	1.4 (35)	2.8 (71)	6.9 (175)	13.9 (353)	2.7 (69)	5.4 (137)	8.6 (218)
150462	62 (1570)	150448	48 (1215)	0.8 (20)	1.6 (40)	4.1 (104)	8.2 (208)	1.6 (41)	3.2 (81)	5.1 (130)
150808	8 (200)	150806	6 (150)	5.0 (127)	10.0 (254)	25.0 (635)	50.0 (1270)	9.8 (188)	19.7 (500)	31.5 (800)
150816	16 (400)	150812	12 (300)	5.0 (127)	10.0 (254)	25.0 (635)	50.0 (1270)	9.8 (249)	19.7 (500)	31.5 (800)
150823	23 (580)	150818	18 (455)	3.5 (89)	6.9 (175)	17.3 (439)	34.6 (879)	6.7 (170)	13.5 (343)	21.6 (549)
150831	31 (785)	150824	24 (600)	2.3 (58)	4.5 (114)	11.3 (287)	22.6 (574)	4.4 (112)	8.8 (224)	14.1 (358)
150839	39 (990)	150830	30 (760)	1.6 (41)	3.2 (81)	8.0 (203)	15.9 (404)	3.1 (79)	6.2 (157)	9.9 (251)
150846	46 (1165)	150836	36 (910)	1.2 (30)	2.4 (61)	6.0 (152)	11.9 (302)	2.3 (58)	4.7 (119)	7.4 (188)
150862	62 (1570)	150848	48 (1215)	0.7 (17)	1.5 (38)	3.6 (91)	7.3 (185)	1.4 (35)	2.8 (71)	4.6 (117)

Footnotes:

- (1) These listed speeds are a mechanical limitation. The maximum speed of a positioning table depends on the screw diameter, screw lead, screw length, and the screw end bearing support configuration. *LINTECH* uses a fixed-simple screw end bearing support configuration in its positioning tables. The correct motor & drive system needs to be selected in order to obtain the above maximum table speeds.

Screws - Acme & Ball

150-WC0 series Model Number	Travel Length inches (mm)	150-WC1 series Model Number	Travel Length inches (mm)	Maximum Safe Table Operating Speed ⁽¹⁾ in/sec (mm/sec)			
				Screw			
				0.750 dia. 0.200 lead	0.750 dia. 0.500 lead	20 mm dia. 5 mm lead	20 mm dia. 20 mm lead
150408	8 (200)	150406	6 (150)	10.0 (254)	25.0 (635)	9.8 (249)	39.3 (998)
150416	16 (400)	150412	12 (300)	10.0 (254)	25.0 (635)	9.8 (249)	39.3 (998)
150423	23 (580)	150418	18 (455)	10.0 (254)	25.0 (635)	9.8 (249)	39.3 (998)
150431	31 (785)	150424	24 (600)	6.7 (170)	16.7 (424)	6.6 (168)	26.3 (668)
150439	39 (990)	150430	30 (760)	4.5 (114)	11.3 (287)	4.5 (114)	17.9 (455)
150446	46 (1165)	150436	36 (910)	3.3 (84)	8.3 (211)	3.3 (84)	13.1 (333)
150462	62 (1570)	150448	48 (1215)	2.0 (51)	4.9 (124)	1.9 (48)	7.8 (198)
150808	8 (200)	150806	6 (150)	10.0 (254)	25.0 (635)	9.8 (249)	39.3 (998)
150816	16 (400)	150812	12 (300)	10.0 (254)	25.0 (635)	9.8 (249)	39.3 (998)
150823	23 (580)	150818	18 (455)	8.3 (211)	20.7 (526)	8.2 (208)	32.7 (831)
150831	31 (785)	150824	24 (600)	5.4 (137)	13.5 (343)	5.3 (135)	21.4 (544)
150839	39 (990)	150830	30 (760)	3.8 (97)	9.5 (241)	3.8 (97)	15.1 (384)
150846	46 (1165)	150836	36 (910)	2.8 (71)	7.1 (180)	2.8 (71)	11.3 (287)
150462	62 (1570)	150848	48 (1215)	1.7 (43)	4.4 (112)	1.7 (43)	6.9 (175)

Footnotes:

- (1) These listed speeds are a mechanical limitation. The maximum speed of a positioning table depends on the screw diameter, screw lead, screw length, and the screw end bearing support configuration. *LINTECH* uses a fixed-simple screw end bearing support configuration in its positioning tables. The correct motor & drive system needs to be selected in order to obtain the above maximum table speeds.

Screws - Acme & Ball

SCREW	ROLLED BALL SCREWS								
	Dyn. ⁽¹⁾ Capacity	Static Capacity	Screw Efficiency	Breakaway Torque	Position Accuracy	Backlash	Unidirectional Repeatability	Bidirectional Repeatability	
	lbs (kg)	lbs (kg)	%	oz-in (N-m)	inch/ft (microns/300 mm)	inches (microns)	inches (microns)	inches (microns)	
0.625 inch dia. 0.200 inch lead	<i>Non-preloaded</i> (S005)	800 (363)	6,150 (2790)	90	10 (0,07)	< 0.003 (75)	+/- 0.0002 (5)	+ 0.0002 to - 0.0082 (5) (208)	
	<i>Preloaded</i> (S006)	720 (326)	6,070 (2753)		20 (0,14)			0	+ 0.0002 to - 0.0002 (5) (5)
	<i>Non-preloaded</i> Turcite Nut (S007)	100 (45)	800 (363)	60	15 (0,11)			< 0.008 (203)	+ 0.0002 to - 0.0082 (5) (208)
	<i>Preloaded</i> Turcite Nut (S008)	90 (41)	800 (363)		30 (0,21)			0	+ 0.0002 to - 0.0002 (5) (5)
0.625 inch dia. 1.000 inch lead	<i>Non-preloaded</i> (S009)	590 (267)	2,425 (1100)	90	25 (0,18)	< 0.004 (100)	+/- 0.0002 (5)	+ 0.0002 to - 0.0082 (5) (208)	
	<i>Preloaded</i> (S010)	530 (240)	2,390 (1084)		40 (0,28)			0	+ 0.0002 to - 0.0002 (5) (5)
	<i>Non-preloaded</i> Turcite Nut (S011)	100 (45)	800 (363)	60	35 (0,25)			< 0.008 (203)	+ 0.0002 to - 0.0082 (5) (208)
	<i>Preloaded</i> Turcite Nut (S012)	90 (41)	800 (363)		60 (0,42)			0	+ 0.0002 to - 0.0002 (5) (5)
0.750 inch dia. 0.200 inch lead	<i>Non-preloaded</i> (S013)	1,900 (862)	18,800 (8527)	90	20 (0,14)	< 0.003 (75)	+/- 0.0002 (5)	+ 0.0002 to - 0.0082 (5) (208)	
	⁽²⁾ <i>Preloaded</i> (S014)	1,710 (776)	18,610 (8441)		30 (0,21)			0	+ 0.0002 to - 0.0002 (5) (5)
	<i>Non-preloaded</i> Turcite Nut (S015)	195 (88)	1,500 (680)	60	25 (0,18)			< 0.008 (203)	+ 0.0002 to - 0.0082 (5) (208)
	<i>Preloaded</i> Turcite Nut (S016)	175 (79)	1,500 (680)		40 (0,28)			0	+ 0.0002 to - 0.0002 (5) (5)
0.750 inch dia. 0.5000 inch lead	<i>Non-preloaded</i> (S017)	3,450 (1565)	24,200 (10977)	90	25 (0,18)	< 0.003 (75)	+/- 0.0002 (5)	+ 0.0002 to - 0.0082 (5) (208)	
	⁽²⁾ <i>Preloaded</i> (S018)	3,150 (1429)	23,855 (10820)		40 (0,28)			0	+ 0.0002 to - 0.0002 (5) (5)
	<i>Non-preloaded</i> Turcite Nut (S019)	195 (88)	1,500 (680)	60	35 (0,25)			< 0.008 (203)	+ 0.0002 to - 0.0082 (5) (208)
	<i>Preloaded</i> Turcite Nut (S020)	175 (79)	1,500 (680)		60 (0,42)			0	+ 0.0002 to - 0.0002 (5) (5)

Footnotes:

- (1) Dynamic load capacity of screw based on 1 million inches of travel (25Km).
- (2) There is a 2.8 inch (71,1 mm) reduction of carriage travel (from the listed travel) when using a preloaded nut with this screw option for all the 150-WC0 (4 inch carriage) model versions. For the 150-WC1 (4 inch carriage) series, 6 inch (150 mm) listed travel, there is a 0.8 inch (20,3 mm) reduction of travel. All other 150-WC1 and all 8 inch carriage models do not have a reduction of travel.

Specifications subject to change without notice

Screws - Acme & Ball

SCREW		PRECISION BALL SCREWS							Bidirectional Repeatability inches (microns)	
		Dyn. ⁽¹⁾ Capacity lbs (kg)	Static Capacity lbs (kg)	Screw Efficiency %	Breakaway Torque oz-in (N-m)	Position Accuracy inch/ft (microns/300 mm)	Backlash inches (microns)	Unidirectional Repeatability inches (microns)		
0.625 inch dia. 0.200 inch lead	<i>Non-preloaded</i> (S114)	876 (397)	2,700 (1224)	90	10 (0,07)	< 0.002 (50)	< 0.003 (76)	+/- 0.0002 (5)	+ 0.0002 to - 0.0032 (5)	- 0.0032 (81)
	<i>Preloaded</i> (S115)	788 (357)	2,430 (1102)		20 (0,14)		0		+ 0.0002 to - 0.0002 (5)	
16 mm dia. 5 mm lead	<i>Non-preloaded</i> (S116)	876 (397)	2,700 (1224)	90	10 (0,07)	< 0.002 (50)	< 0.003 (76)	+/- 0.0002 (5)	+ 0.0002 to - 0.0032 (5)	- 0.0032 (81)
	<i>Preloaded</i> (S117)	788 (357)	2,430 (1102)		20 (0,14)		0		+ 0.0002 to - 0.0002 (5)	
16 mm dia. 10 mm lead	<i>Non-preloaded</i> (S118)	1,080 (489)	2,630 (1192)	90	15 (0,11)	< 0.002 (50)	< 0.003 (76)	+/- 0.0002 (5)	+ 0.0002 to - 0.0032 (5)	- 0.0032 (81)
	⁽²⁾ <i>Preloaded</i> (S119)	972 (440)	2,365 (1072)		25 (0,18)		0		+ 0.0002 to - 0.0002 (5)	
16 mm dia. 16 mm lead	<i>Non-preloaded</i> (S120)	819 (371)	1,620 (734)	90	20 (0,14)	< 0.002 (50)	< 0.003 (76)	+/- 0.0002 (5)	+ 0.0002 to - 0.0032 (5)	- 0.0032 (81)
	⁽³⁾ <i>Preloaded</i> (S121)	737 (334)	1,455 (659)		35 (0,24)		0		+ 0.0002 to - 0.0002 (5)	
0.750 inch dia. 0.200 inch lead	<i>Non-preloaded</i> (S122)	964 (437)	3,360 (1524)	90	15 (0,11)	< 0.002 (50)	< 0.003 (76)	+/- 0.0002 (5)	+ 0.0002 to - 0.0032 (5)	- 0.0032 (81)
	⁽⁴⁾ <i>Preloaded</i> (S123)	867 (393)	3,025 (1372)		25 (0,18)		0		+ 0.0002 to - 0.0002 (5)	
20 mm dia. 5 mm lead	<i>Non-preloaded</i> (S124)	1,070 (485)	3,990 (1809)	90	15 (0,11)	< 0.002 (50)	< 0.003 (76)	+/- 0.0002 (5)	+ 0.0002 to - 0.0032 (5)	- 0.0032 (81)
	⁽⁴⁾ <i>Preloaded</i> (S125)	960 (435)	3,590 (1628)		25 (0,18)		0		+ 0.0002 to - 0.0002 (5)	
20 mm dia. 20 mm lead	<i>Non-preloaded</i> (S128)	1,293 (586)	3,505 (1589)	90	25 (0,18)	< 0.002 (50)	< 0.003 (76)	+/- 0.0002 (5)	+ 0.0002 to - 0.0032 (5)	- 0.0032 (81)
	⁽⁵⁾ <i>Preloaded</i> (S129)	1,160 (526)	3,150 (1428)		40 (0,28)		0		+ 0.0002 to - 0.0002 (5)	

Footnotes:

- (1) Dynamic load capacity of screw based on 1 million inches of travel (25Km).
- (2) There is a 0.9 inch (22,9 mm) reduction of carriage travel (from the listed travel) when using a preloaded nut with this screw option for all the 150-WC0 (4 inch carriage) model versions. All 150-WC0 (8 inch carriages) and all 150-WC1 models do not have a reduction of travel.
- (3) There is a 1.1 inch (27,9 mm) reduction of carriage travel (from the listed travel) when using a preloaded nut with this screw option for all the 150-WC0 (4 inch carriage) model versions. All 150-WC0 (8 inch carriages) and all 150-WC1 models do not have a reduction of travel.
- (4) There is a 0.5 inch (12,7 mm) reduction of carriage travel (from the listed travel) when using a preloaded nut with this screw option for all the 150-WC0 (4 inch carriage) model versions. All 150-WC0 (8 inch carriages) and all 150-WC1 models do not have a reduction of travel.
- (5) There is a 1.7 inch (43,2 mm) reduction of carriage travel (from the listed travel) when using a preloaded nut with this screw option for all the 150-WC0 (4 inch carriage) model versions. All 150-WC0 (8 inch carriages) and all 150-WC1 models do not have a reduction of travel.

Specifications subject to change without notice

Screws - Acme & Ball

SCREW	GROUND BALL SCREWS							
	Dyn. ⁽¹⁾ Capacity	Static Capacity	Screw Efficiency	Breakaway Torque	Position Accuracy	Backlash	Unidirectional Repeatability	Bidirectional Repeatability
	lbs (kg)	lbs (kg)	%	oz-in (N-m)	inch/ft (microns/300 mm)	inches (microns)	inches (microns)	inches (microns)
0.625 dia., 0.200 lead (2) <i>Preloaded</i> (S212)	987 (447)	3,080 (1397)	90	20 (0,14)	< 0.0006 (15)	0	+/- 0.0001 (2,5)	+ 0.0001 to - 0.0001 (2,5)
0.625 dia., 0.500 lead (2) <i>Preloaded</i> (S213)	1430 (649)	4,191 (1901)	90	30 (0,21)	< 0.0006 (15)	0	+/- 0.0001 (2,5)	+ 0.0001 to - 0.0001 (2,5)
16 mm dia., 5 mm lead (2) <i>Preloaded</i> (S214)	987 (447)	3,080 (1397)	90	20 (0,14)	< 0.0006 (15)	0	+/- 0.0001 (2,5)	+ 0.0001 to - 0.0001 (2,5)
16 mm dia., 16 mm lead (2) <i>Preloaded</i> (S215)	910 (412)	1,800 (816)	90	35 (0,24)	< 0.0006 (15)	0	+/- 0.0001 (2,5)	+ 0.0001 to - 0.0001 (2,5)
0.750 dia., 0.200 lead (3) <i>Preloaded</i> (S216)	1,070 (485)	3,990 (1809)	90	25 (0,18)	< 0.0006 (15)	0	+/- 0.0001 (2,5)	+ 0.0001 to - 0.0001 (2,5)
0.750 dia., 0.500 lead (3) <i>Preloaded</i> (S217)	1,200 (544)	4,200 (1905)	90	35 (0,24)	< 0.0006 (15)	0	+/- 0.0001 (2,5)	+ 0.0001 to - 0.0001 (2,5)

SCREW	ROLLED ACME SCREWS							
	Dyn. ⁽¹⁾ Capacity	Static Capacity	Screw Efficiency	Breakaway Torque	Position Accuracy	Backlash	Unidirectional Repeatability	Bidirectional Repeatability
	lbs (kg)	lbs (kg)	%	oz-in (N-m)	inch/ft (microns/300 mm)	inches (microns)	inches (microns)	inches (microns)
0.625 inch dia. 0.100 inch lead	<i>Non-preloaded</i> (S300)	160 (73)	800 (363)	40	10 (0,07)	< 0.008 (203)	+/- 0.0002 (5)	+ 0.0002 to - 0.0082 (5)
	<i>Preloaded</i> (S301)	140 (64)	720 (327)		20 (0,14)	< 0.003 (75)		0
0.625 inch dia. 0.200 inch lead	<i>Non-preloaded</i> (S302)	160 (73)	800 (363)	40	15 (0,11)	< 0.008 (203)	+/- 0.0002 (5)	+ 0.0002 to - 0.0082 (5)
	<i>Preloaded</i> (S303)	140 (64)	720 (327)		30 (0,21)	< 0.003 (75)		0

Footnotes:

- (1) Dynamic load capacity of screw based on 1 million inches of travel (25Km).
(2) The 0.625 inch & 16 mm diameter Ground Ball Screw options are only available in travel lengths where the screw length is less than 47 inches (1194 mm).
(3) The 0.750 inch diameter Ground Ball Screw options are only available in travel lengths where the screw length is less than 47 inches (1194 mm).

Motor Couplings

LINTECH provides three different types of couplings that can be used to mount a motor to a positioning table. These couplings compensate for misalignment between the motor shaft & screw shaft extension. This provides for trouble-free operation as long as certain precautions are taken. The connected motor output torque should never exceed the coupling maximum torque capacity. Larger capacity couplings may be required for applications having high accelerations, large back driving loads, high torque output motors, or servo motors.

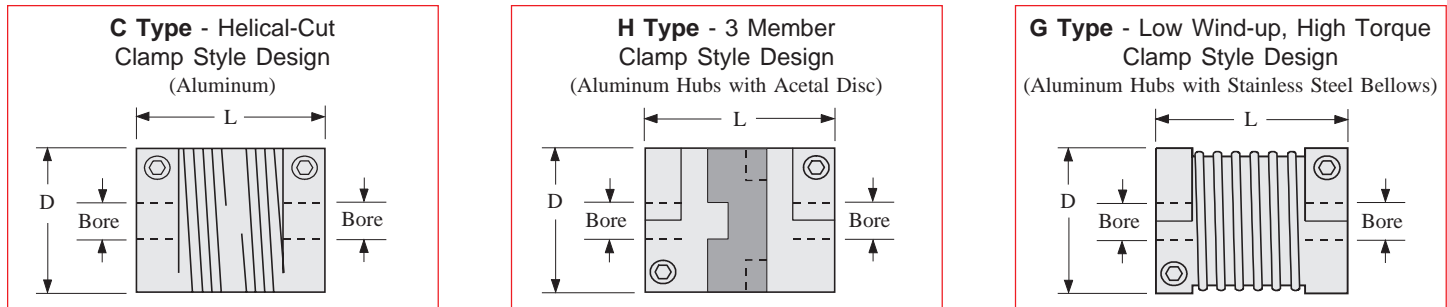

Model # ⁽¹⁾	D inches (mm)	L inches (mm)	Bore Diameters				Weight ounces (grams)	Inertia oz-in ² (g-cm ²)	Wind-up arc-sec/oz-in (deg/N-m)	Max Torque oz-in (N-m)
			Table	Motor	Minimum (in) (mm)	Maximum (in) (mm)				
C100-375-aaa	1.00 (25,4)	1.50 (38,1)	375	aaa	.250 6	.375 10	1.5 (43)	.19 (35)	23.0 (0,9)	400 (2,8)
C125-375-aaa	1.25 (31,8)	2.00 (50,8)	375	aaa	.250 6	.500 14	3.5 (99)	.68 (124)	15.0 (0,59)	700 (4,9)
H100-375-aaa	1.00 (25,4)	1.28 (32,5)	375	aaa	.250 6	.375 10	1.2 (34)	.15 (27)	7.2 (0,28)	450 (2,8)
H131-375-aaa	1.31 (33,3)	1.89 (48,0)	375	aaa	.250 6	.625 16	2.9 (82)	.62 (114)	2.5 (0,098)	1,000 (7,1)
G100-375-aaa	0.99 (25,2)	1.26 (32,0)	375	aaa	.250 6	.500 12	1.3 (36)	.16 (29)	1.0 (0,39)	500 (3,5)
G126-375-aaa	1.26 (32,1)	1.62 (41,0)	375	aaa	.250 6	.625 16	2.7 (74)	.54 (99)	0.3 (0,012)	1,100 (7,7)
Possible values for aaa	250 = .250 inch 375 = .375 inch 500 = .500 inch 625 = .625 inch			005 = 5 mm 006 = 6 mm 008 = 8 mm 010 = 10 mm		012 = 12 mm 014 = 14 mm 016 = 16 mm				

Footnotes:

- (1) See page G-25 for maximum coupling diameter and length specifications for use with the optional NEMA 23 & 34 motor mounts. Custom motor mounts can be provided upon request.

Motor Couplings

Coupling	Cost	Torque Capacity	Wind-up	Suggested Motor	Comments
C Type	least expensive	light	the most	stepper	ideal for most step motor applications
H Type	medium priced	medium	medium	stepper or servo	use for high accels & for starting & stopping large inertia loads
G Type	most expensive	high	the least	servo	use for very high torque requirements & very high servo accelerations

Specification	150 Series	150 Series
	NEMA 23 bracket	NEMA 34 bracket
	inches (mm)	inches (mm)
Shaft extension diameter at motor mount end	0.375 (9,53)	0.375 (9,53)
Maximum coupling diameter	1.500 (38,10)	1.500 (38,10)
Maximum coupling length	2.100 (53,34)	2.600 (66,04)
Note: Custom brackets available upon request.		

Coupling Part Numbers

C025 C100-375-250	C130 H100-375-250	C407 G100-375-250
C026 C100-375-375	C131 H100-375-375	C408 G100-375-375
C027 C100-375-006	C132 H100-375-006	C409 G100-375-500
C028 C100-375-008	C133 H100-375-008	C410 G100-375-006
C029 C100-375-010	C134 H100-375-010	C411 G100-375-008
		C412 G100-375-010
		C413 G100-375-012
C048 C125-375-250	C155 H131-375-250	C435 G126-375-250
C049 C125-375-375	C156 H131-375-375	C436 G126-375-375
C050 C125-375-500	C157 H131-375-500	C437 G126-375-500
C051 C125-375-006	C158 H131-375-625	C438 G126-375-625
C052 C125-375-008	C159 H131-375-006	C439 G126-375-006
C053 C125-375-010	C160 H131-375-008	C440 G126-375-008
C054 C125-375-012	C161 H131-375-010	C441 G126-375-010
C055 C125-375-014	C162 H131-375-012	C442 G126-375-012
	C163 H131-375-014	C443 G126-375-014
	C164 H131-375-016	C444 G126-375-016

NEMA 34 Motor Mount

The NEMA 34 motor adapter bracket is an aluminum flange that mounts to the front of the NEMA 23 motor mount. The bracket can be ordered in either an English, or Metric motor mount. *LINTECH* can provide adapter brackets for any step motor, or servo motor, that has other mounting requirements.

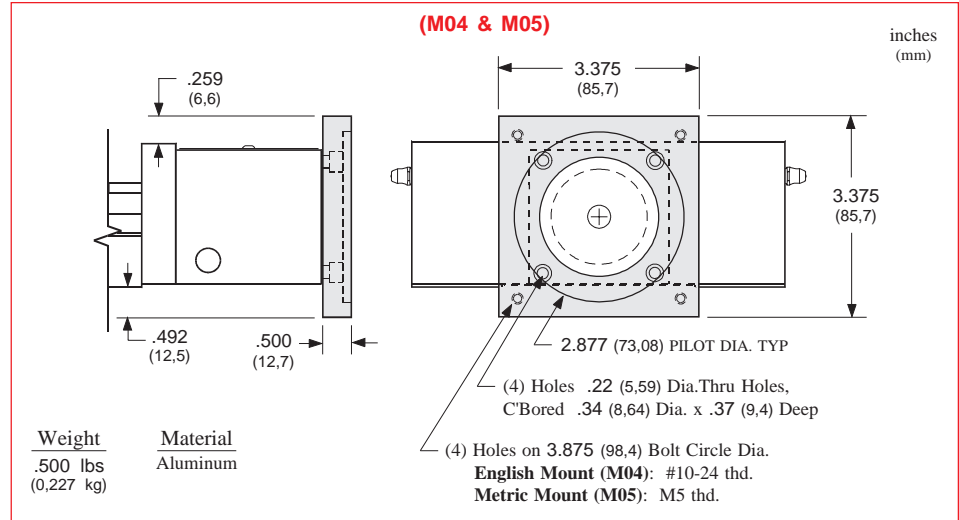

Hand Crank

For manually operated applications, *LINTECH* provides a hand crank option for the 150 table series. The hand crank replaces the motor mount and coupling on the table.

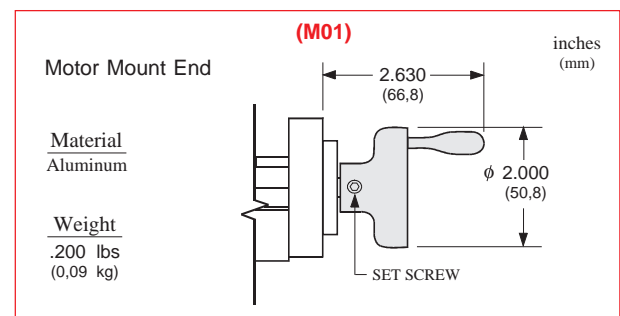

Chrome Plated Linear Bearings, Rails, and Screws

For applications in high moisture, high humidity, clean room, or highly corrosive environments, chrome plating of the linear bearings, linear rails, and screw will offer superior resistance to corrosion than stainless steel components, resulting in longer table life. The process uniformly deposits dense, hard, high chromium alloy on the rails or screw, and has a Rockwell C hardness value of 67-72. This process also conforms to MIL Spec: (MIL-C-23422). The chrome plating bonds to the parent material and will not crack or peel off under the high point loading of balls on the rail, or screw. This chrome plating process differs from a normal hard chrome plate which just lays on the surface of the part plated.

Motor Wrap Packages

For space limited 150 series applications, a belt and pulley system can couple the screw shaft extension to the motor shaft. This wraps the motor parallel to the table in order to decrease the overall positioning system length. Pulley weights and diameters are given in order to assist in calculating motor torque requirements.

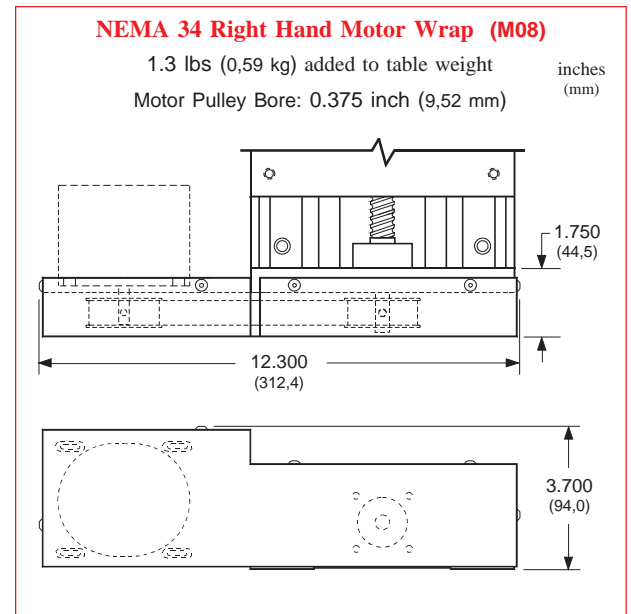
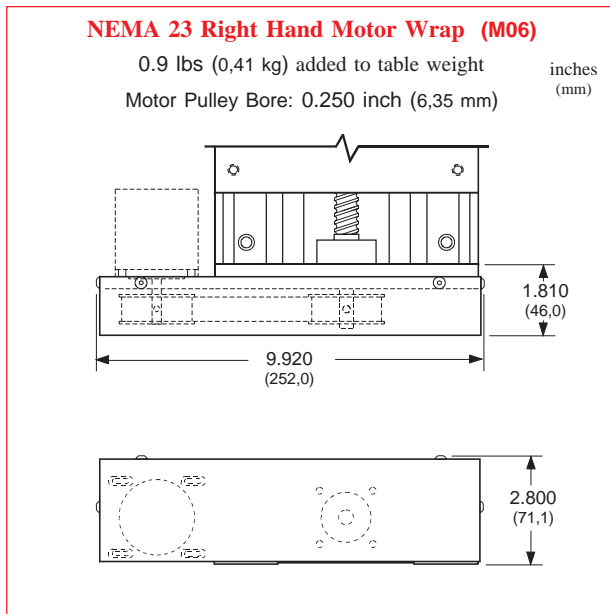

Motor Wrap Frame Size	Motor Pulley Dia. inches (mm)	Motor Pulley Wt. ounces (kg)	Screw Pulley Dia. inches (mm)	Screw Pulley Wt. ounces (kg)	Belt Weight ounces (kg)
NEMA 23	1.65 (41,9)	7.5 (0,21)	1.65 (41,9)	7.5 (0,21)	1.0 (0,028)
NEMA 34	1.65 (41,9)	8.0 (0,23)	1.65 (41,9)	8.0 (0,23)	1.2 (0,034)

Note: Right hand motor wraps shown. The left hand wrap packages orient the motor to the opposite side of the table. Motor pulley & belt shipped "loose". No motor mount nuts & bolts are provided. Custom motor wrap packages are available upon request. Other motor pulley bores **MUST** be specified for non-NEMA motors.

Power-off Electric Brakes

For vertical table applications, or for those applications requiring the load to be locked securely in place, an electric brake may be mounted to the positioning table. The 150 series will have the brake mounted to the screw shaft extension located on the table end, opposite the motor mount bracket. With proper wiring from a control system, this power-off friction brake can ensure that the carriage is firmly held in place, when no electric power is applied to the brake. When power is applied to the brake, the brake is opened or "released".

For proper emergency braking of the positioning table, this electric brake needs to be interfaced to a position controller or relay network. *LINTECH* also provides 24 & 90 VDC power supplies which can be used to power the brakes.

Brakes

Model Number	Holding Force		Excitation Voltage	Current	Weight
	in-lbs (N-m)	volts			
B01	18 (2,0)	24 VDC	0.733	1.4 (0,62)	
B02	18 (2,0)	90 VDC	0.178	1.4 (0,62)	

Note: This power-off electric brake MUST NOT be engaged when the positioning table is in motion. Moving the table with the brake applied could damage the brake and the positioning table. Also, continuous use of this brake to stop a table (load) that is in motion could damage the brake and the positioning table. Dynamic braking of a positioning table should be done by the motor and not the brake.

Power Supplies

Model Number	DC Output			AC Input		
	volts	amps	style	volts	amps	Hz
41970	5	3.0	regulated	120 / 240	0.8 / 0.4	47-63
37488	24	1.2	regulated	120 / 240	0.8 / 0.4	47-63
37489	90	0.8	unregulated	120	1.0	50/60
37490	90	0.8	unregulated	240	0.5	50/60

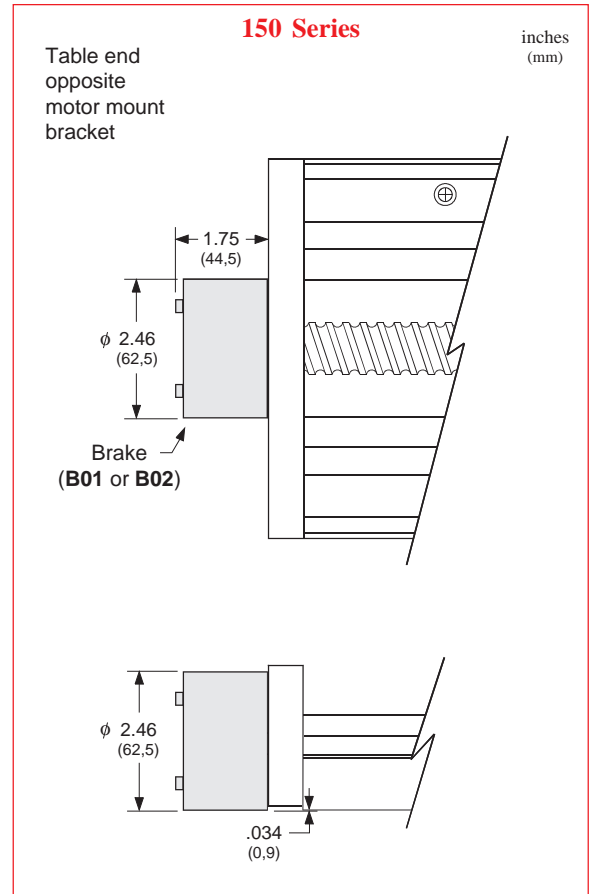

Linear & Rotary Incremental Encoders

Fully enclosed, incremental, optical linear encoders can be mounted along side any *LINTECH* 150 series table. Shaftless, incremental, optical rotary encoders can be mounted to the screw shaft extension opposite the motor mount end on the 150 series positioning tables. These encoders provide positional feedback to either a motion controller, or a digital position display.

LINEAR		ROTARY	Description
Din Pin #	Wire Color	Wire Color	
C	Green	White	Channel A+ (or A)
D	Yellow	Blue	Channel A- (or \bar{A})
E	Pink	Green	Channel B+ (or B)
L	Red	Orange	Channel B- (or \bar{B})
G	Brown	White/Black	Channel Z+ (or Z)
H	Grey	Red/Black	Channel Z- (or \bar{Z})
A	Shield		Case ground
B	White	Black	Common
K	Black	Red	+ 5 vdc (+/- 5%)

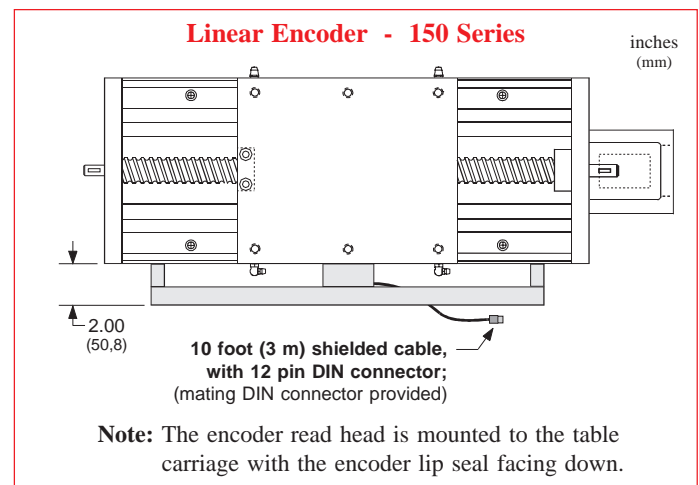
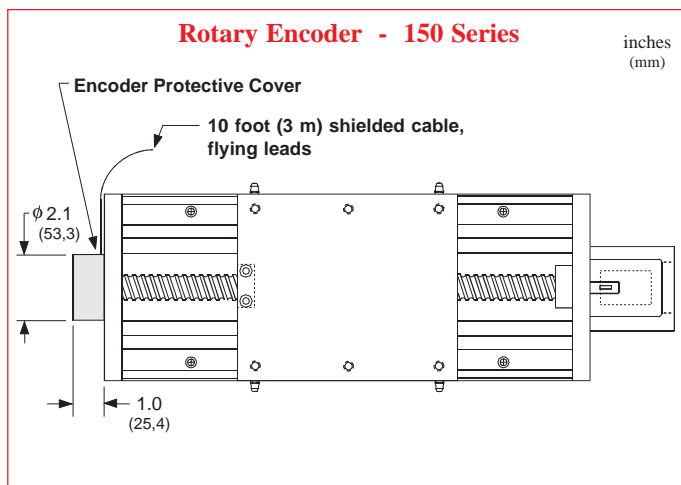

Specification	ROTARY ENCODERS			LINEAR ENCODERS	
	E01	E02	E03	E10	E11
Line Count	500 lines/rev	1000 lines/rev	1270 lines/rev	2500 lines/inch	125 lines/mm
Pre Quadrature Resolution	0.002 revs/pulse	0.001 revs/pulse	0.00079 revs/pulse	0.0004 inch/pulse	8 microns/pulse
Post Quadrature Resolution	0.0005 revs/pulse	0,00025 revs/pulse	0.00019 revs/pulse	0.0001 inch/pulse	2 micron/pulse
Accuracy				+/- 0.0002 in/40"	+/- 5 microns/m
Maximum Speed	50 revs/sec			79 inches/sec	2 m/sec
Maximum Accel	40 revs/sec ²			130 ft/sec ²	40 m/sec ²
Excitation Power	+ 5 VDC @ 125 ma			+ 5 VDC @ 150 ma	
Operating Temperature	32° F to 140° F (0° C to 60° C)			32° F to 120° F (0° C to 50° C)	
Humidity	20% to 80% non condensing			20% to 80% non condensing	
Shock	10 G's for 11 msec duration			15 G's for 8 msec duration	
Weight	0.7 lbs (0,283 kg)			0.7 oz/inch (0,00078 kg/mm) length of scale + 0.5 lbs (0,23 kg) read head and brackets	
Cable Length	10 ft (3 m), unterminated 26 gauge leads			10 ft (3 m) with DIN connector	
Zero Reference Output	Once per revolution			At center of encoder length	
Outputs	TTL square wave; Two channel (A+ & B+); Differential (A- & B-); Line Driver				

Specifications subject to change without notice

