

# 100, 110, & 120 Series Positioning Tables

100 Series Specifications _____	<b>C-5</b>
110 Series Specifications _____	<b>C-13</b>
Thrust Capacity (axial load) _____	<b>C-16</b>
Screw Travel Life _____	<b>C-17</b>
Screw Options _____	<b>C-18</b>
120 Series Specifications _____	<b>C-27</b>
Maximum Acceleration - 120 _____	<b>C-32</b>
Master/Slave - 120 _____	<b>C-33</b>
Gearheads _____	<b>C-34</b>
Table Deflection _____	<b>C-36</b>
Linear Bearing Load Capacity _____	<b>C-38</b>
EOT & Home Switches _____	<b>C-39</b>
Motor Couplings _____	<b>C-42</b>
Angle Brackets _____	<b>C-44</b>
Carriage Adapter Plates _____	<b>C-46</b>
Motor Mount Options _____	<b>C-48</b>
Power-off Electric Brakes _____	<b>C-50</b>
Linear & Rotary Encoders _____	<b>C-51</b>

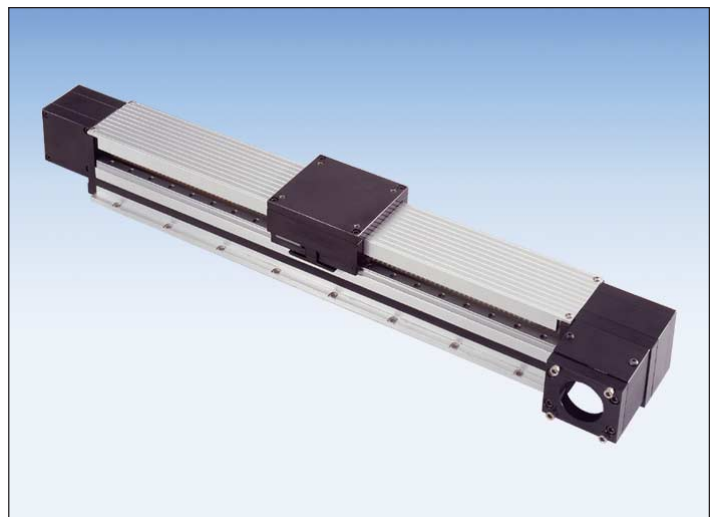
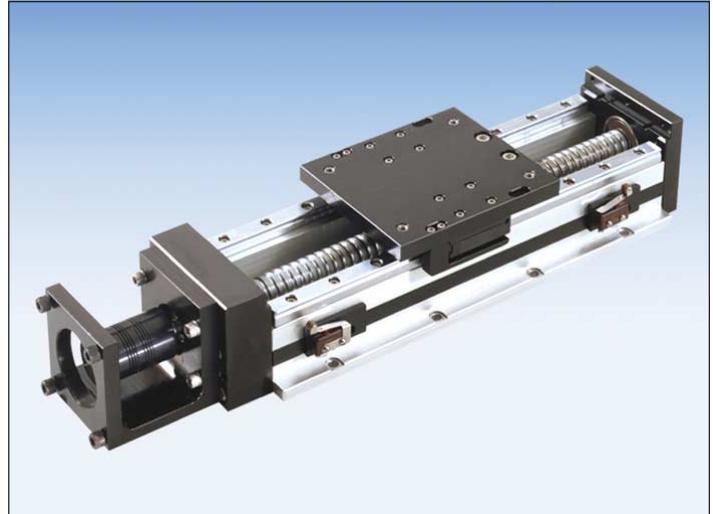

## Single or Multiple Axis

LINTECH's 100 & 110 series positioning tables offer precision performance and design flexibility for use in a wide variety of Motion Control applications.

- ❑ Welding
- ❑ Test Stands
- ❑ Part Insertion
- ❑ Laser Positioning
- ❑ Liquid Dispensing
- ❑ Semiconductor Processing
- ❑ Gluing
- ❑ Pick & Place
- ❑ Part Scanning
- ❑ Inspection Stations
- ❑ General Automation

## Quality Construction

LINTECH's 100 & 110 series tables are designed to maximize performance while minimizing physical size and cost. These tables use a low friction, preloaded, recirculating linear ball bearing system, which rides on precision ground linear rails. The linear rails are mounted to a precision machined aluminum base, which offers a rigid support over the entire travel of the table's carriage. The load is mounted to a precision machined aluminum carriage, which has threaded stainless steel inserts for high strength and wear life. There are 30 different acme & ball screw options, that offer high efficiencies and long life at an economical price. These tables are designed to allow for numerous options. They include EOT & Home switches, linear & rotary encoders, power-off electric brakes, motor wrap packages and versatile mounting brackets for multiple axis applications.

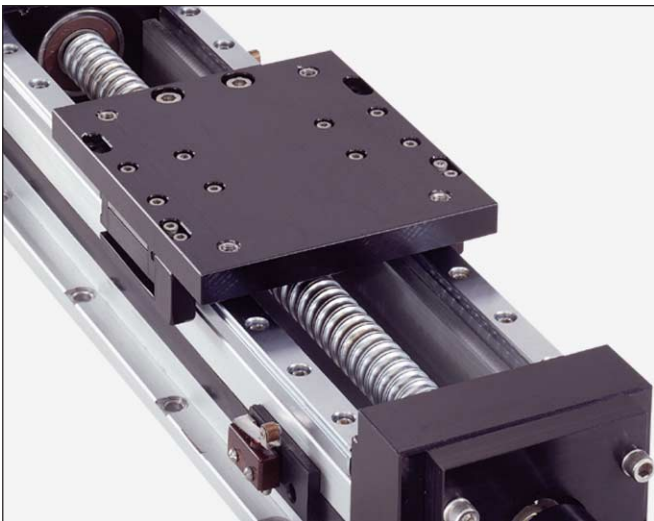

## Available Options

### Acme Screws & Ball Screws

An assortment of acme screws and ball screws can be installed in the 100 & 110 series tables, providing solutions to load back driving, high duty cycle, high speed, extreme smoothness, and sensitive positioning applications.

### Carriage Adapter Plates & Vertical Angle Brackets

Optional carriage adapter plates and vertical angle brackets can be mounted directly to the top of various LINTECH positioning tables, thus providing for easy multiple axis configurations.

### Cover Plates and Waycovers

For harsh environmental conditions, or for operator protection, these tables can be fitted with either aluminum cover plates, or a waycover. The entire length of the lead screw and linear bearing system will be covered.

### End of Travel and Home Switches

The 100 & 110 series tables can be provided with end of travel (EOT) and home switches mounted and wired for each axis. Most position controllers can utilize the EOT switches to stop carriage motion when the extreme table travel has been reached in either direction. The home switch provides a known mechanical location on the table.

### Linear and Rotary Encoders

Incremental encoders can be mounted to the table in order to provide positional data back to either a motion controller, or a digital display.

### Motor Adapter Brackets

NEMA 23, NEMA 34, or any metric mount motor can be mounted to a 100 & 110 series positioning table with the use of adapter brackets.

### Turcite Nut With Rolled Ball Screw

This solid polymer nut has no rolling elements in it, and performs very similar to an acme nut. It can provide smoother motion & less audible noise than most ball nuts, and is ideal for corrosive & vertical applications.

### Other

The 100 & 110 series tables can accommodate **chrome plated linear bearings, rails, & screws** for corrosive environment applications, **power-off electric brakes** for load locking applications, **motor wrap packages** for space limited applications, and a **hand crank** for manually operated applications.

### Standard Features - 100 & 110 Series

- Compact 3.50 inches (89 mm) wide by 2.375 inches (60 mm) tall - 100 series
- Compact 5.25 inches (133 mm) wide by 2.375 inches (60 mm) tall - 110 series
- Travel lengths from 2 inches (50 mm) to 60 inches (1520 mm)
- Threaded stainless steel inserts in carriage for load mounting
- 0° F to +185° F (-18° C to +85° C) operating temperature
- Recirculating linear ball bearing system
- Precision ground square rail design
- 2 rails, 2 or 4 bearing carriages

#### 100-CP0 Series

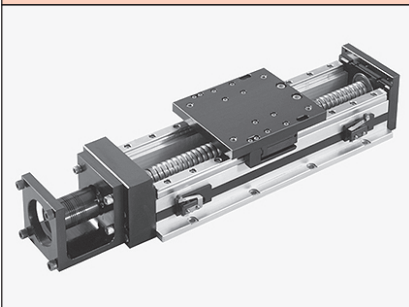

#### 100-CP1 Series



#### 100-CP2 Series



#### 110-WC1 Series

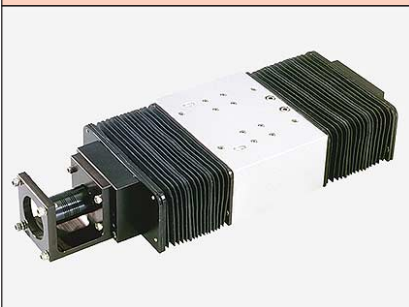

#### Options - 100 & 110 Series

- Chrome plated linear bearings, rails and screws
- End of travel (EOT) and home switches wired
- AUTOCAD® drawings available upon request
- Adapter brackets for non-NEMA motors
- Linear and rotary incremental encoders
- NEMA 23 & 34 motor wrap packages
- NEMA 34 adapter bracket
- Power-off electric brakes
- Carriage adapter plates
- Vertical angle bracket
- Turcite nut option
- Motor couplings
- Cover plates
- Waycovers
- Hand crank

- Ball screws:

##### Rolled - Non-preloaded & Preloaded Nuts:

- 0.625 inch diameter, 0.200 inch lead
- \* 0.500 inch diameter, 0.500 inch lead
- 0.625 inch diameter, 1.000 inch lead

##### Precision - Non-preloaded & Preloaded Nuts:

- 0.625 inch diameter, 0.200 inch lead
- 16 mm diameter, 5 mm lead
- \* 16 mm diameter, 10 mm lead
- \* 16 mm diameter, 16 mm lead

##### Ground - Preloaded Nuts Only:

- 0.625 inch diameter, 0.200 inch lead
- 16 mm diameter, 5 mm lead
- 16 mm diameter, 16 mm lead

\* (Reduction of travel with preloaded nut)

- Acme screws:

##### Rolled - Non-preloaded & Preloaded Nuts:

- 0.625 inch diameter, 0.100 inch lead
- 0.625 inch diameter, 0.200 inch lead
- 16 mm diameter, 4 mm lead

**10** - **4** - **4** - **02** - **CP0** - **1** - **S114** - **M02** - **C145** - **L01** - **E00** - **B00**

**Table Series**

**Number of Bearings**

- 2 - 2 bearing per carriage
- 4 - 4 bearings per carriage

**Carriage Length**

- 4 - 4 inches

**Travel Length** (see pages C-6, C-8 & C-10)

- 02 - 2 to 60 inches

**Cover Plate**

- CP0** - no cover plates
- CP1** - top cover plate only
- CP2** - top & side cover plates

**Carriage Inserts** (see pages C-7, C-9 & C-11)

- 1 - English mount
- 2 - Metric mount

**Screw Options** (see pages C-18 to C-23)

Rolled ball screws

- S001** - .500 x .500 NPL
- S002** - .500 x .500 PL
- S003** - .500 x .500 NPL(T)
- S004** - .500 x .500 PL(T)
- S005** - .625 x .200 NPL
- S006** - .625 x .200 PL
- S007** - .625 x .200 NPL(T)
- S008** - .625 x .200 PL(T)
- S009** - .625 x 1.000 NPL
- S010** - .625 x 1.000 PL
- S011** - .625 x 1.000 NPL(T)
- S012** - .625 x 1.000 PL(T)

Precision ball screws

- S114** - .625 x .200 NPL
- S115** - .625 x .200 PL
- S116** - 16 x 5 NPL
- S117** - 16 x 5 PL
- S118** - 16 x 10 NPL
- S119** - 16 x 10 PL
- S120** - 16 x 16 NPL
- S121** - 16 x 16 PL
- S999** - other

Ground ball screws

- S212** - .625 x .200 PL
- S213** - .625 x .500 PL
- S214** - 16 x 5 PL
- S215** - 16 x 16 PL

Rolled acme screws

- S300** - .625 x .100 NPL
- S301** - .625 x .100 PL
- S302** - .625 x .200 NPL
- S303** - .625 x .200 PL
- S304** - 16 x 4 NPL
- S305** - 16 x 4 PL

**Motor Mount** (see pages C-7, C-9, C-11, C-48 & C-49)

- M00** - none
- M01** - hand crank
- M99** - other
- M02** - NEMA 23 mount (E)
- M03** - NEMA 23 mount (M)
- M04** - NEMA 34 mount (E)
- M05** - NEMA 34 mount (M)
- M06** - NEMA 23 (RH) wrap
- M07** - NEMA 23 (LH) wrap
- M08** - NEMA 34 (RH) wrap
- M09** - NEMA 34 (LH) wrap

**Coupling Options** (see pages C-42 to C-43)

- C000** - none
- C999** - other
- C020 to C024** - C100
- C040 to C047** - C125
- C125 to C129** - H100
- C145 to C154** - H131
- C400 to C406** - G100
- C425 to C434** - G126

**Limit & Home Switches** (see pages C-39 to C-41)

- L00** - no switches
- L99** - other
- EOT & home switches
- EOT switches only
- home switch only
- Mechanical**
- Reed**
- Hall**
- Prox (NPN)**
- Prox (PNP)**
- L01**
- L02**
- L03**
- L04**
- L05**
- L06**
- L07**
- L08**
- L09**
- L10**
- L11**
- L12**
- L13**
- L14**
- L15**

**Encoder Options** (see page C-51)

- E00** - none
- E01** - rotary (500 lines/rev)
- E02** - rotary (1000 lines/rev)
- E03** - rotary (1270 lines/rev)
- E10** - linear (2500 lines/inch)
- E11** - linear (250 lines/mm)
- E99** - other

**Power-off Brakes** (see page C-50)

- B00** - none
- B01** - 24 VDC
- B02** - 90 VDC
- B99** - other

- (E) - English Interface
- (LH) - Left Hand
- (M) - Metric Interface
- (NPL) - Non Preloaded
- (PL) - Preloaded
- (RH) - Right Hand
- (T) - Turcite Nut

Specifications subject to change without notice

## Specifications

Made in the U.S.A.

Load Capacities		Two (2) Bearing Carriage		Four (4) Bearing Carriage	
<b>Dynamic Horizontal</b>	2 million inches (50 km) of travel	1,550 lbs	( 703 kg)	3,100 lbs	( 1406 kg)
<b>Dynamic Horizontal</b>	50 million inches (1270 km) of travel	525 lbs	( 238 kg)	1,060 lbs	( 480 kg)
<b>Static Horizontal</b>		2,360 lbs	( 1070 kg)	4,720 lbs	( 2140 kg)
<b>Dynamic Roll Moment</b>	2 million inches (50 km) of travel	140 ft-lbs	( 190 N-m)	280 ft-lbs	( 379 N-m)
<b>Dynamic Roll Moment</b>	50 million inches (1270 km) of travel	47 ft-lbs	( 64 N-m)	95 ft-lbs	( 129 N-m)
<b>Static Roll Moment</b>		210 ft-lbs	( 285 N-m)	425 ft-lbs	( 576 N-m)
<b>Dyn. Pitch &amp; Yaw Moment</b>	2 million inches (50 km) of travel	18 ft-lbs	( 24 N-m)	240 ft-lbs	( 325 N-m)
<b>Dyn. Pitch &amp; Yaw Moment</b>	50 million inches (1270 km) of travel	6 ft-lbs	( 8 N-m)	82 ft-lbs	( 111 N-m)
<b>Static Pitch &amp; Yaw Moment</b>		30 ft-lbs	( 41 N-m)	365 ft-lbs	( 495 N-m)
<b>Each Bearing Dyn. Capacity</b>	2 million inches (50 km) of travel	775 lbs	( 351 kg)	775 lbs	( 351 kg)
<b>Each Bearing Dyn. Capacity</b>	50 million inches (1270 km) of travel	263 lbs	( 119 kg)	263 lbs	( 119 kg)
<b>Each Bearing Static Load Capacity</b>		1,180 lbs	( 535 kg)	1,180 lbs	( 535 kg)
<b>Thrust Force Capacity</b>	10 million screw revolutions	665 lbs	( 302 kg)	665 lbs	( 302 kg)
<b>Thrust Force Capacity</b>	500 million screw revolutions	180 lbs	( 82 kg)	180 lbs	( 82 kg)
<b>Maximum Acceleration</b>		386 in/sec <sup>2</sup>	( 9,8 m/sec <sup>2</sup> )	772 in/sec <sup>2</sup>	( 19,6 m/sec <sup>2</sup> )
<b>d<sub>1</sub></b>	Center to center distance (spread) between the two rails	2.375 in	( 60,3 mm)	2.375 in	( 60,3 mm)
<b>d<sub>2</sub></b>	Center to center distance (spacing) of the bearings on a single rail	-		2.088 in	( 53,0 mm)
<b>d<sub>r</sub> CP0 version</b>	Center distance of the bearing to top of carriage plate surface	.750 in	( 19,1 mm)	.750 in	( 19,1 mm)
<b>d<sub>r</sub> CP1 version</b>	Center distance of the bearing to top of carriage plate surface	1.375 in	( 34,9 mm)	1.375 in	( 34,9 mm)

Other	For Two (2) & Four (4) Bearing Carriages
<b>Table Material</b>	Base, Carriage, End Plates, & Cover Plate option - 6061 anodized aluminum
<b>Linear Rail Material</b>	Case Hardened Steel
<b>Screw Material</b> (see pages C-18 to C-23)	Acme Screw - Stainless Steel
<b>Screw Material</b> (see pages C-18 to C-23)	Rolled Ball, Precision Ball, & Ground Ball - Case Hardened Steel
<b>Straightness</b>	< 0.00013 in/in (< 3,30 microns/25mm)
<b>Flatness</b>	< 0.00013 in/in (< 3,30 microns/25mm)
<b>Orthogonality</b> (multi-axis systems)	< 30 arc-seconds
<b>Friction Coefficient</b>	< 0.01
<b>Motor Mount</b>	NEMA 23 & 34 Mounts, Metric Mounts, Motor Wraps, and Hand Crank Option
<b>Coupling</b>	Three (3) different styles available

Specifications subject to change without notice

## Dimensions & Specifications

- Without Cover Plates -

Made in the U.S.A.

Model Number	Travel Length inches (mm)	Table Dimensions inches (mm)		Mounting Dimensions inches (mm)				Screw Length inches (mm)	Table <sup>(1)</sup> Weight lbs (kg)
		A	B	C	D	E	M		
<b>10x402-CP0</b>	2 (50)	6.0 (152,4)	9.875 (250,8)	0.500 (12,7)	1.250 (31,7)	1	8	9.25 (235)	5.1 (2,3)
<b>10x404-CP0</b>	4 (100)	8.0 (203,2)	11.875 (301,6)	0.250 (6,3)	2.500 (63,5)	1	8	11.25 (286)	5.9 (2,7)
<b>10x406-CP0</b>	6 (150)	10.0 (254,0)	13.875 (352,4)	1.250 (31,7)	2.500 (63,5)	1	8	13.25 (337)	6.7 (3,0)
<b>10x408-CP0</b>	8 (200)	12.0 (304,8)	15.875 (403,2)	0.250 (6,3)	2.000 (50,8)	3	12	15.25 (387)	7.5 (3,4)
<b>10x412-CP0</b>	12 (300)	16.0 (406,4)	19.875 (504,8)	0.250 (6,3)	1.500 (38,1)	5	16	19.25 (489)	9.1 (4,1)
<b>10x416-CP0</b>	16 (400)	20.0 (508,0)	23.875 (606,4)	1.250 (31,7)	2.500 (63,5)	5	16	23.25 (591)	10.7 (4,8)
<b>10x420-CP0</b>	20 (500)	24.0 (609,6)	27.875 (708,0)	0.750 (19,0)	2.500 (63,5)	7	20	27.25 (692)	12.3 (5,6)
<b>10x424-CP0</b>	24 (600)	28.0 (711,2)	31.875 (809,6)	0.250 (6,3)	2.500 (63,5)	9	24	31.25 (794)	13.9 (6,3)
<b>10x430-CP0</b>	30 (760)	34.0 (863,6)	37.875 (962,0)	0.750 (19,0)	2.500 (63,5)	11	28	37.25 (946)	16.3 (7,4)
<b>10x436-CP0</b>	36 (910)	40.0 (1016,0)	43.875 (1114,4)	1.250 (31,7)	2.500 (63,5)	13	32	43.25 (1099)	18.7 (8,5)
<b>10x442-CP0</b>	42 (1060)	46.0 (1168,4)	49.875 (1266,8)	1.750 (44,4)	2.500 (63,5)	15	36	49.25 (1251)	21.1 (9,6)
<b>10x448-CP0</b>	48 (1210)	52.0 (1320,8)	55.875 (1419,2)	2.250 (57,1)	2.500 (63,5)	17	40	55.25 (1403)	23.5 (10,6)
<b>10x454-CP0</b>	54 (1370)	58.0 (1473,2)	61.875 (1571,6)	0.250 (6,3)	2.500 (63,5)	21	48	61.25 (1556)	25.9 (11,4)
<b>10x460-CP0</b>	60 (1520)	64.0 (1625,6)	67.875 (1724,0)	0.75 (19,0)	2.500 (63,5)	23	52	67.25 (1708)	28.3 (12,8)

- x = 2; Carriage has 2 bearings; Carriage weight = 1.2 lbs. (0,54 kg)
- x = 4; Carriage has 4 bearings; Carriage weight = 1.4 lbs. (0,63 kg)

### Footnotes:

(1) Weight shown is with a 0.625 inch (16 mm) diameter screw, a 2 bearing carriage [1.2 lbs (0,54 kg)], a NEMA 23 motor mount [0.34 lbs (0,16 kg)], and a C100 style [0.09 lbs (0,04 kg)] coupling. When using a 0.500 inch diameter screw subtract 0.022 lbs per inch (0,00039 kg per mm) of screw length for a given model number. When using a 4 bearing carriage add 0.2 lbs (0,09 kg) to each value.

## Dimensions

### - Without Cover Plates -

Made in the U.S.A.

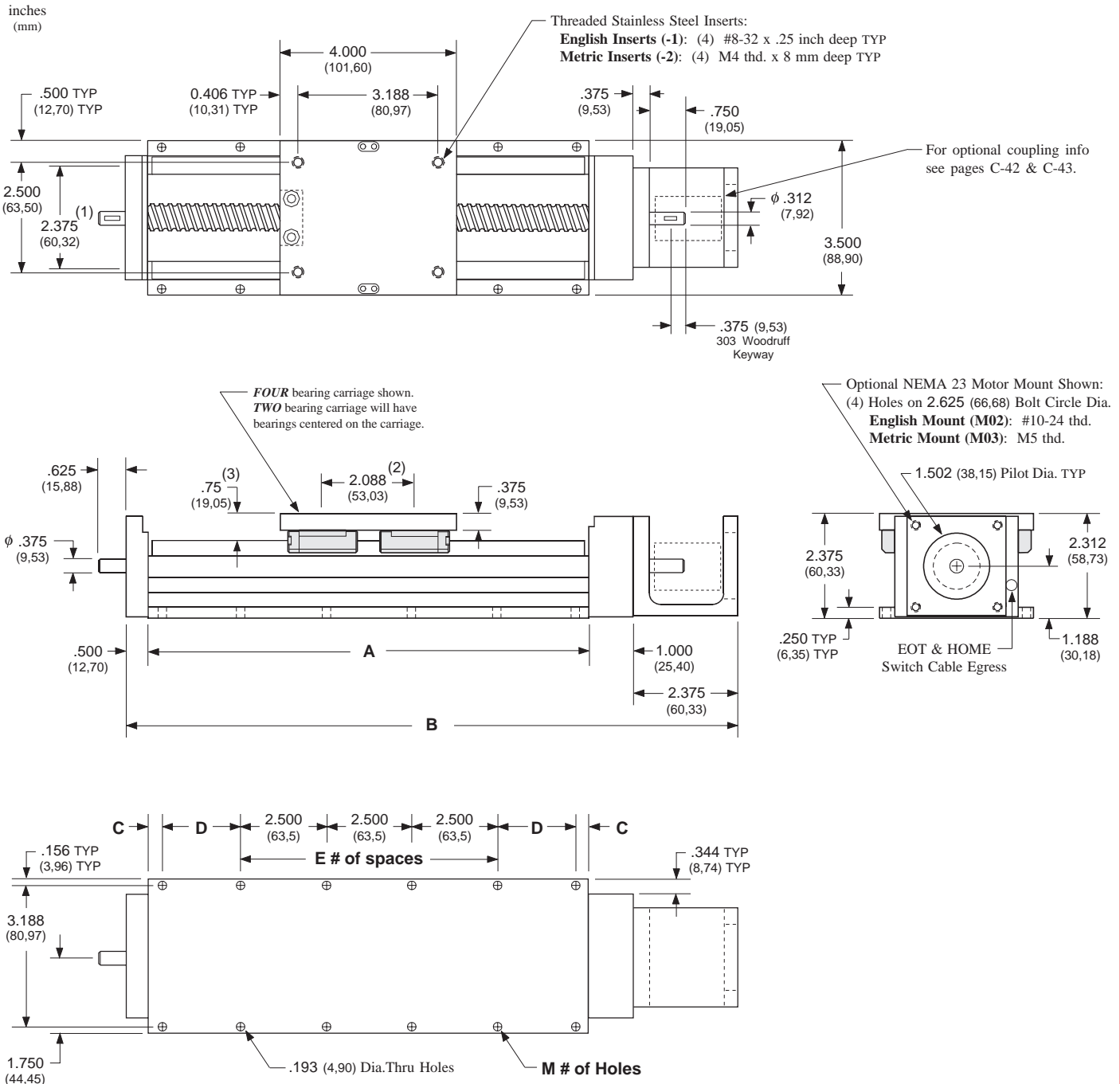

- (1) This value is center to center distance (spread) between the two rails ( $d_1$ ).
- (2) This value is center to center distance (spacing) of the bearings on a single rail ( $d_2$ ).
- (3) This value is center distance of the bearing to top of carriage plate surface ( $d_r$ ).

**Note:** Any 100, 110, 120 or 130 series table can be mounted on top of any second 100, 110, 120 series table by the user, in order to create X-Y multiple axis configurations. The 100-CP1, 100-CP2, or 120 series tables require one of the *Carriage Adapter Plate* options. The carriage's threaded stainless steel insert hole pattern exactly matches the base mounting hole pattern on each table, therefore no extra adapter bracket or machining is required. However a precision square tool, or micrometer depth gauge, is required in order to obtain an orthogonality between the two tables of < 30 arc-seconds. The table base, carriage top & carriage sides are all precision machined. *LINTECH's* 100 series, 4 bearing carriage, should be used for the bottom axis in a multiple axes application for better system rigidity, performance, and life.

## Dimensions & Specifications

- With Top Cover Plate Only -

Made in the U.S.A.

Model Number	Travel Length inches (mm)	Table Dimensions inches (mm)		Mounting Dimensions inches (mm)				Screw Length inches (mm)	Table <sup>(1)</sup> Weight lbs (kg)
		A	B	C	D	E	M		
<b>10x402-CP1</b>	2 (50)	6.0 (152,4)	9.875 (250,8)	0.500 (12,7)	1.250 (31,7)	1	8	9.25 (235)	6.1 (2,8)
<b>10x404-CP1</b>	4 (100)	8.0 (203,2)	11.875 (301,6)	0.250 (6,3)	2.500 (63,5)	1	8	11.25 (286)	7.0 (3,2)
<b>10x406-CP1</b>	6 (150)	10.0 (254,0)	13.875 (352,4)	1.250 (31,7)	2.500 (63,5)	1	8	13.25 (337)	7.9 (3,6)
<b>10x408-CP1</b>	8 (200)	12.0 (304,8)	15.875 (403,2)	0.250 (6,3)	2.000 (50,8)	3	12	15.25 (387)	8.8 (4,0)
<b>10x412-CP1</b>	12 (300)	16.0 (406,4)	19.875 (504,8)	0.250 (6,3)	1.500 (38,1)	5	16	19.25 (489)	10.6 (4,8)
<b>10x416-CP1</b>	16 (400)	20.0 (508,0)	23.875 (606,4)	1.250 (31,7)	2.500 (63,5)	5	16	23.25 (591)	12.3 (5,6)
<b>10x420-CP1</b>	20 (500)	24.0 (609,6)	27.875 (708,0)	0.750 (19,0)	2.500 (63,5)	7	20	27.25 (692)	14.0 (6,3)
<b>10x424-CP1</b>	24 (600)	28.0 (711,2)	31.875 (809,6)	0.250 (6,3)	2.500 (63,5)	9	24	31.25 (794)	15.9 (7,2)
<b>10x430-CP1</b>	30 (760)	34.0 (863,6)	37.875 (962,0)	0.750 (19,0)	2.500 (63,5)	11	28	37.25 (946)	18.6 (8,4)
<b>10x436-CP1</b>	36 (910)	40.0 (1016,0)	43.875 (1114,4)	1.250 (31,7)	2.500 (63,5)	13	32	43.25 (1099)	21.3 (9,7)
<b>10x442-CP1</b>	42 (1060)	46.0 (1168,4)	49.875 (1266,8)	1.750 (44,4)	2.500 (63,5)	15	36	49.25 (1251)	24.0 (10,9)
<b>10x448-CP1</b>	48 (1210)	52.0 (1320,8)	55.875 (1419,2)	2.250 (57,1)	2.500 (63,5)	17	40	55.25 (1403)	26.7 (12,1)
<b>10x454-CP1</b>	54 (1370)	58.0 (1473,2)	61.875 (1571,6)	0.250 (6,3)	2.500 (63,5)	21	48	61.25 (1556)	29.4 (13,3)
<b>10x460-CP1</b>	60 (1520)	64.0 (1625,6)	67.875 (1724,0)	0.75 (19,0)	2.500 (63,5)	23	52	67.25 (1708)	32.1 (14,6)

- x = 2; Carriage has 2 bearings; Carriage weight = 1.5 lbs. (0,68 kg)
- x = 4; Carriage has 4 bearings; Carriage weight = 1.7 lbs. (0,77 kg)

### Footnotes:

(1) Weight shown is with a 0.625 inch (16 mm) diameter screw, a 2 bearing carriage [1.5 lbs (0,68 kg)], a NEMA 23 motor mount [0.34 lbs (0,16 kg)], and a C100 style [0.09 lbs (0,04 kg)] coupling. When using a 0.500 inch diameter screw subtract 0.022 lbs per inch (0,00039 kg per mm) of screw length for a given model number. When using a 4 bearing carriage add 0.2 lbs (0,09 kg) to each value.

## Dimensions

### - With Top Cover Plate Only -

Made in the U.S.A.

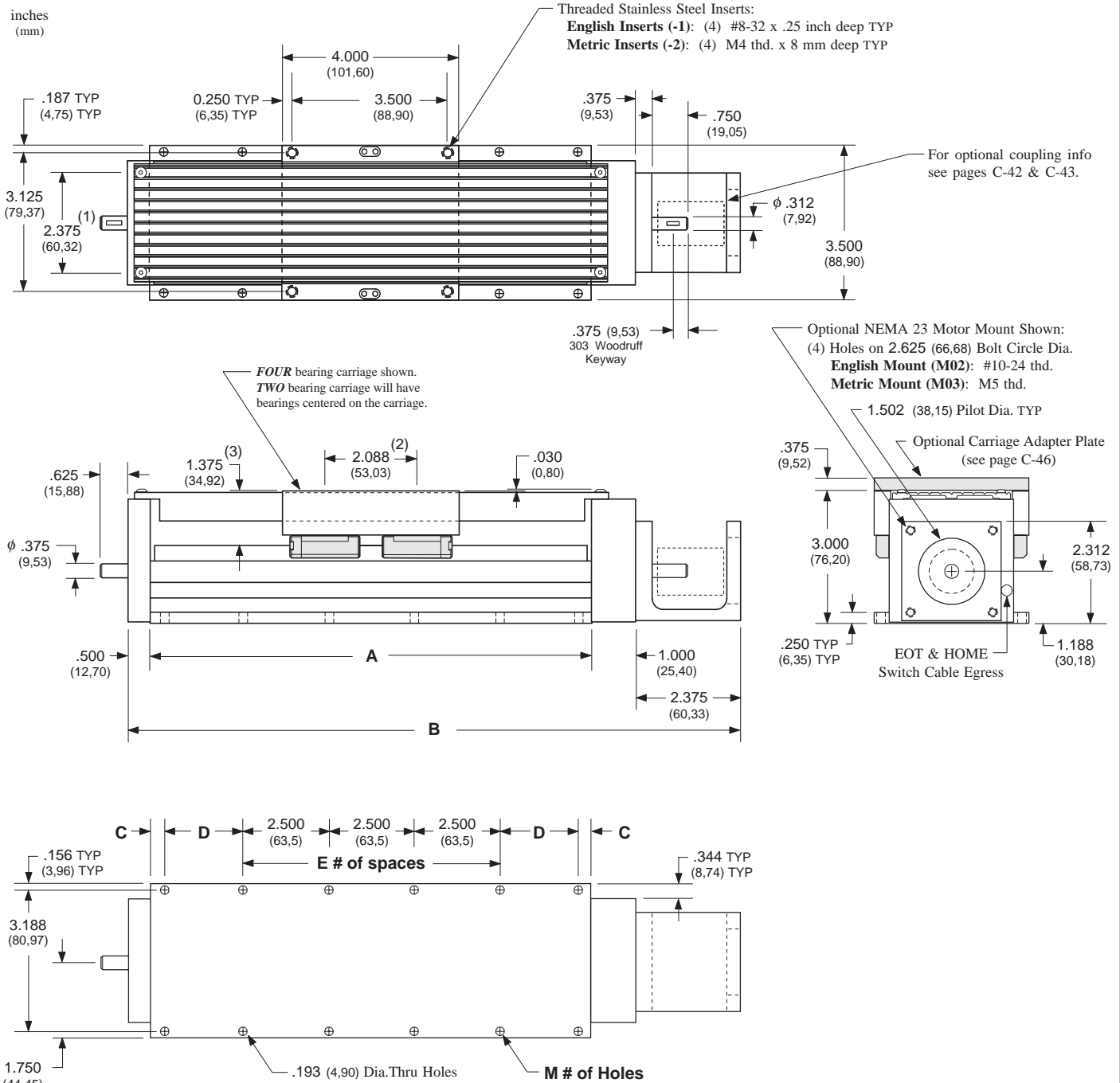

C

- (1) This value is center to center distance (spread) between the two rails ( $d_1$ ).
- (2) This value is center to center distance (spacing) of the bearings on a single rail ( $d_2$ ).
- (3) This value is center distance of the bearing to top of carriage plate surface ( $d_3$ ).

**Note:** Any 100, 110, 120, or 130 series table can be mounted on top of any second 100, 110, 120 series table by the user, in order to create X-Y multiple axis configurations. The 100-CP1, 100-CP2, or 120 series tables require one of the *Carriage Adapter Plate* options. The carriage's threaded stainless steel insert hole pattern exactly matches the base mounting hole pattern on each table, therefore no extra adapter bracket or machining is required. However a precision square tool, or micrometer depth gauge, is required in order to obtain an orthogonality between the two tables of < 30 arc-seconds. The table base, carriage top & carriage sides are all precision machined. *LINTECH's* 100 series, 4 bearing carriage, should be used for the bottom axis in a multiple axes application for better system rigidity, performance, and life.

## Dimensions & Specifications

- With Top & Side Cover Plates -

Made in the U.S.A.

Model Number	Travel Length inches (mm)	Table Dimensions inches (mm)		Mounting Dimensions inches (mm)				Screw Length inches (mm)	Table <sup>(1)</sup> Weight lbs (kg)
		A	B	C	D	E	M		
<b>10x402-CP2</b>	2 (50)	6.0 (152,4)	9.875 (250,8)	0.500 (12,7)	1.250 (31,7)	1	8	9.25 (235)	6.4 (2,9)
<b>10x404-CP2</b>	4 (100)	8.0 (203,2)	11.875 (301,6)	0.250 (6,3)	2.500 (63,5)	1	8	11.25 (286)	7.3 (3,3)
<b>10x406-CP2</b>	6 (150)	10.0 (254,0)	13.875 (352,4)	1.250 (31,7)	2.500 (63,5)	1	8	13.25 (337)	8.3 (3,8)
<b>10x408-CP2</b>	8 (200)	12.0 (304,8)	15.875 (403,2)	0.250 (6,3)	2.000 (50,8)	3	12	15.25 (387)	9.2 (4,2)
<b>10x412-CP2</b>	12 (300)	16.0 (406,4)	19.875 (504,8)	0.250 (6,3)	1.500 (38,1)	5	16	19.25 (489)	11.1 (5,0)
<b>10x416-CP2</b>	16 (400)	20.0 (508,0)	23.875 (606,4)	1.250 (31,7)	2.500 (63,5)	5	16	23.25 (591)	13.0 (5,9)
<b>10x420-CP2</b>	20 (500)	24.0 (609,6)	27.875 (708,0)	0.750 (19,0)	2.500 (63,5)	7	20	27.25 (692)	14.8 (6,7)
<b>10x424-CP2</b>	24 (600)	28.0 (711,2)	31.875 (809,6)	0.250 (6,3)	2.500 (63,5)	9	24	31.25 (794)	16.8 (7,6)
<b>10x430-CP2</b>	30 (760)	34.0 (863,6)	37.875 (962,0)	0.750 (19,0)	2.500 (63,5)	11	28	37.25 (946)	19.6 (8,9)
<b>10x436-CP2</b>	36 (910)	40.0 (1016,0)	43.875 (1114,4)	1.250 (31,7)	2.500 (63,5)	13	32	43.25 (1099)	22.5 (10,2)
<b>10x442-CP2</b>	42 (1060)	46.0 (1168,4)	49.875 (1266,8)	1.750 (44,4)	2.500 (63,5)	15	36	49.25 (1251)	25.4 (11,5)
<b>10x448-CP2</b>	48 (1210)	52.0 (1320,8)	55.875 (1419,2)	2.250 (57,1)	2.500 (63,5)	17	40	55.25 (1403)	28.2 (12,8)
<b>10x454-CP2</b>	54 (1370)	58.0 (1473,2)	61.875 (1571,6)	0.250 (6,3)	2.500 (63,5)	21	48	61.25 (1556)	31.1 (14,1)
<b>10x460-CP2</b>	60 (1520)	64.0 (1625,6)	67.875 (1724,0)	0.75 (19,0)	2.500 (63,5)	23	52	67.25 (1708)	34.0 (15,4)

- x = 2; Carriage has 2 bearings; Carriage weight = 1.5 lbs. (0,68 kg)
- x = 4; Carriage has 4 bearings; Carriage weight = 1.7 lbs. (0,77 kg)

### Footnotes:

(1) Weight shown is with a 0.625 inch (16 mm) diameter screw, a 2 bearing carriage [1.5 lbs (0,68 kg)], a NEMA 23 motor mount [0.34 lbs (0,16 kg)], and a C100 style [0.09 lbs (0,04 kg)] coupling. When using a 0.500 inch diameter screw subtract 0.022 lbs per inch (0,00039 kg per mm) of screw length for a given model number. When using a 4 bearing carriage add 0.2 lbs (0,09 kg) to each value.

## Dimensions

### - With Top & Side Cover Plates -

Made in the U.S.A.

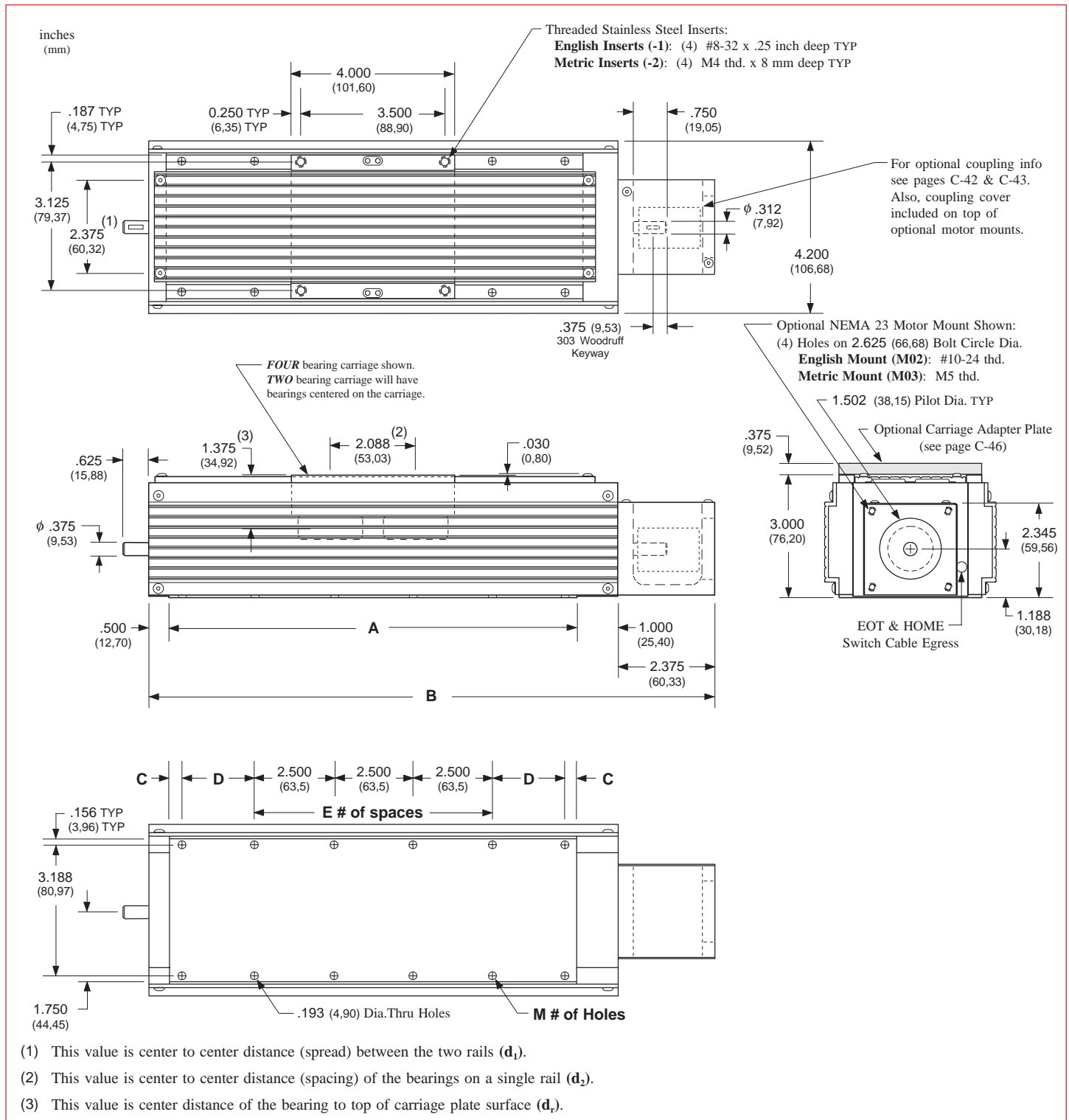

C

**Note:** Any 100, 110, 120, or 130 series table can be mounted on top of any second 100, 110, 120 series table by the user, in order to create X-Y multiple axis configurations. The 100-CP1, 100-CP2, or 120 series tables require one of the *Carriage Adapter Plate* options. The carriage's threaded stainless steel insert hole pattern exactly matches the base mounting hole pattern on each table, therefore no extra adapter bracket or machining is required. However a precision square tool, or micrometer depth gauge, is required in order to obtain an orthogonality between the two tables of < 30 arc-seconds. The table base, carriage top & carriage sides are all precision machined. *LINTECH's* 100 series, 4 bearing carriage, should be used for the bottom axis in a multiple axes application for better system rigidity, performance, and life.

**11** - **4** - **4** - **01** - **WC1** - **1** - **S114** - **M02** - **C145** - **L01** - **E00** - **B00**

**Table Series**

**Number of Bearings**

- 2 - 2 bearing per carriage
- 4 - 4 bearings per carriage

**Carriage Length**

- 4 - 4 inches

**Travel Length** (see page C-14)

- 01 - 1 to 45 inches

**Waycovers**

- WC1 - with waycovers

**Carriage Inserts** (see pages C-15)

- 1 - English mount
- 2 - Metric mount

**Screw Options** (see pages C-18 to C-23)

Rolled ball screws

- S001 - .500 x .500 NPL
- S002 - .500 x .500 PL
- S003 - .500 x .500 NPL(T)
- S004 - .500 x .500 PL(T)
- S005 - .625 x .200 NPL
- S006 - .625 x .200 PL
- S007 - .625 x .200 NPL(T)
- S008 - .625 x .200 PL(T)
- S009 - .625 x 1.000 NPL
- S010 - .625 x 1.000 PL
- S011 - .625 x 1.000 NPL(T)
- S012 - .625 x 1.000 PL(T)

Precision ball screws

- S114 - .625 x .200 NPL
- S115 - .625 x .200 PL
- S116 - 16 x 5 NPL
- S117 - 16 x 5 PL
- S118 - 16 x 10 NPL
- S119 - 16 x 10 PL
- S120 - 16 x 16 NPL
- S121 - 16 x 16 PL
- S999 - other

Ground ball screws

- S212 - .625 x .200 PL
- S213 - .625 x .500 PL
- S214 - 16 x 5 PL
- S215 - 16 x 16 PL

Rolled acme screws

- S300 - .625 x .100 NPL
- S301 - .625 x .100 PL
- S302 - .625 x .200 NPL
- S303 - .625 x .200 PL
- S304 - 16 x 4 NPL
- S305 - 16 x 4 PL

**Motor Mount** (see pages C-15, C-48 & C-49)

- M00 - none
- M01 - hand crank
- M99 - other
- M02 - NEMA 23 mount (E)
- M03 - NEMA 23 mount (M)
- M04 - NEMA 34 mount (E)
- M05 - NEMA 34 mount (M)
- M06 - NEMA 23 (RH) wrap
- M07 - NEMA 23 (LH) wrap
- M08 - NEMA 34 (RH) wrap
- M09 - NEMA 34 (LH) wrap

**Coupling Options** (see pages C-42 to C-43)

- C000 - none
- C999 - other
- C020 to C024 - C100
- C040 to C047 - C125
- C125 to C129 - H100
- C145 to C154 - H131
- C400 to C406 - G100
- C425 to C434 - G126

**Limit & Home Switches** (see pages C-39 to C-41)

- |                   |                     |            |      |      |            |            |
|-------------------|---------------------|------------|------|------|------------|------------|
| L00 - no switches |                     | Mechanical | Reed | Hall | Prox (NPN) | Prox (PNP) |
| L99 - other       | EOT & home switches | L01        | L04  | L07  | L10        | L13        |
|                   | EOT switches only   | L02        | L05  | L08  | L11        | L14        |
|                   | home switch only    | L03        | L06  | L09  | L12        | L15        |

**Encoder Options** (see page C-51)

- E00 - none
- E01 - rotary (500 lines/rev)
- E02 - rotary (1000 lines/rev)
- E03 - rotary (1270 lines/rev)
- E10 - linear (2500 lines/inch)
- E11 - linear (250 lines/mm)
- E99 - other

**Power-off Brakes** (see page C-50)

- B00 - none
- B01 - 24 VDC
- B02 - 90 VDC
- B99 - other

- (E) - English Interface
- (LH) - Left Hand
- (M) - Metric Interface
- (NPL) - Non Preloaded
- (PL) - Preloaded
- (RH) - Right Hand
- (T) - Turcite Nut

Specifications subject to change without notice

## Specifications

Made in the U.S.A.

Load Capacities		Two (2) Bearing Carriage	Four (4) Bearing Carriage
<b>Dynamic Horizontal</b>	2 million inches (50 km) of travel	1,550 lbs ( 703 kg)	3,100 lbs ( 1406 kg)
<b>Dynamic Horizontal</b>	50 million inches (1270 km) of travel	525 lbs ( 238 kg)	1,060 lbs ( 480 kg)
<b>Static Horizontal</b>		2,360 lbs ( 1070 kg)	4,720 lbs ( 2140 kg)
<b>Dynamic Roll Moment</b>	2 million inches (50 km) of travel	140 ft-lbs ( 190 N-m)	280 ft-lbs ( 379 N-m)
<b>Dynamic Roll Moment</b>	50 million inches (1270 km) of travel	47 ft-lbs ( 64 N-m)	95 ft-lbs ( 129 N-m)
<b>Static Roll Moment</b>		210 ft-lbs ( 285 N-m)	425 ft-lbs ( 576 N-m)
<b>Dyn. Pitch &amp; Yaw Moment</b>	2 million inches (50 km) of travel	18 ft-lbs ( 24 N-m)	240 ft-lbs ( 325 N-m)
<b>Dyn. Pitch &amp; Yaw Moment</b>	50 million inches (1270 km) of travel	6 ft-lbs ( 8 N-m)	82 ft-lbs ( 111 N-m)
<b>Static Pitch &amp; Yaw Moment</b>		30 ft-lbs ( 41 N-m)	365 ft-lbs ( 495 N-m)
<b>Each Bearing Dyn. Capacity</b>	2 million inches (50 km) of travel	775 lbs ( 351 kg)	775 lbs ( 351 kg)
<b>Each Bearing Dyn. Capacity</b>	50 million inches (1270 km) of travel	263 lbs ( 119 kg)	263 lbs ( 119 kg)
<b>Each Bearing Static Load Capacity</b>		1,180 lbs ( 535 kg)	1,180 lbs ( 535 kg)
<b>Thrust Force Capacity</b>	10 million screw revolutions	665 lbs ( 302 kg)	665 lbs ( 302 kg)
<b>Thrust Force Capacity</b>	500 million screw revolutions	180 lbs ( 82 kg)	180 lbs ( 82 kg)
<b>Maximum Acceleration</b>		386 in/sec <sup>2</sup> ( 9,8 m/sec <sup>2</sup> )	772 in/sec <sup>2</sup> ( 19,6 m/sec <sup>2</sup> )
<b>d<sub>1</sub></b>	Center to center distance (spread) between the two rails	2.375 in ( 60,3 mm)	2.375 in ( 60,3 mm)
<b>d<sub>2</sub></b>	Center to center distance (spacing) of the bearings on a single rail	-	2.088 in ( 53,0 mm)
<b>d<sub>r</sub></b>	Center distance of the bearing to top of carriage plate surface	.750 in ( 19,1 mm)	.750 in ( 19,1 mm)

C

Other	For Two (2) & Four (4) Bearing Carriages
<b>Table Material</b>	Base, Carriage, End Plates, & Cover Plate option - 6061 anodized aluminum
<b>Linear Rail Material</b>	Case Hardened Steel
<b>Screw Material</b> (see pages C-18 to C-23)	Acme Screw - Stainless Steel
<b>Screw Material</b> (see pages C-18 to C-23)	Rolled Ball, Precision Ball, & Ground Ball - Case Hardened Steel
<b>Straightness</b>	< 0.00013 in/in (< 3,30 microns/25mm)
<b>Flatness</b>	< 0.00013 in/in (< 3,30 microns/25mm)
<b>Orthogonality</b> (multi-axis systems)	< 30 arc-seconds
<b>Friction Coefficient</b>	< 0.01
<b>Motor Mount</b>	NEMA 23 & 34 Mounts, Metric Mounts, Motor Wraps, and Hand Crank Option
<b>Coupling</b>	Three (3) different styles available
<b>Waycover Material</b>	Hypilon Polyester Bellows firmly mounted to carriage & end plates

Specifications subject to change without notice

## Dimensions & Specifications

- With Waycovers -

Made in the U.S.A.

Model Number	Travel Length inches (mm)	Table Dimensions inches (mm)		Mounting Dimensions inches (mm)				Screw Length inches (mm)	Table <sup>(1)</sup> Weight lbs (kg)
		A	B	C	D	E	M		
<b>11x401-WC1</b>	1.000 (25)	6.250 (158,7)	9.875 (250,8)	0.500 (12,7)	1.250 (31,7)	1	8	9.25 (235)	6.3 (2,9)
<b>11x402-WC1</b>	2.500 (63)	8.250 (203,2)	11.875 (301,6)	0.250 (6,3)	2.500 (63,5)	1	8	11.25 (286)	7.3 (3,3)
<b>11x404-WC1</b>	4.000 (100)	10.250 (260,3)	13.875 (352,4)	1.250 (31,7)	2.500 (63,5)	1	8	13.25 (337)	8.2 (3,7)
<b>11x405-WC1</b>	5.500 (139)	12.250 (311,1)	15.875 (403,2)	0.250 (6,3)	2.000 (50,8)	3	12	15.25 (387)	9.2 (4,2)
<b>11x408-WC1</b>	8.500 (215)	16.250 (412,7)	19.875 (504,8)	0.250 (6,3)	1.500 (38,1)	5	16	19.25 (489)	11.1 (5,0)
<b>11x411-WC1</b>	11.500 (292)	20.250 (514,3)	23.875 (606,4)	1.250 (31,7)	2.500 (63,5)	5	16	23.25 (591)	13.0 (5,9)
<b>11x414-WC1</b>	14.375 (365)	24.250 (615,9)	27.875 (708,0)	0.750 (19,0)	2.500 (63,5)	7	20	27.25 (692)	14.9 (6,8)
<b>11x417-WC1</b>	17.375 (441)	28.250 (717,5)	31.875 (809,6)	0.250 (6,3)	2.500 (63,5)	9	24	31.25 (794)	16.9 (7,7)
<b>11x422-WC1</b>	22.000 (558)	34.250 (869,9)	37.875 (962,0)	0.750 (19,0)	2.500 (63,5)	11	28	37.25 (946)	19.8 (9,0)
<b>11x428-WC1</b>	28.000 (711)	40.250 (1022,3)	43.875 (1114,4)	1.250 (31,7)	2.500 (63,5)	13	32	43.25 (1099)	22.6 (10,2)
<b>11x431-WC1</b>	31.750 (806)	46.250 (1174,7)	49.875 (1266,8)	1.750 (44,4)	2.500 (63,5)	15	36	49.25 (1251)	25.5 (11,6)
<b>11x436-WC1</b>	36.375 (923)	52.250 (1327,1)	55.875 (1419,2)	2.250 (57,1)	2.500 (63,5)	17	40	55.25 (1403)	28.4 (12,9)
<b>11x440-WC1</b>	40.750 (1035)	58.250 (1479,5)	61.875 (1571,6)	0.250 (6,3)	2.500 (63,5)	21	48	61.25 (1556)	31.3 (14,2)
<b>11x445-WC1</b>	45.500 (1155)	64.250 (1631,9)	67.875 (1724,0)	0.75 (19,0)	2.500 (63,5)	23	52	67.25 (1708)	34.1 (15,5)

- ┌ x = 2; Carriage has 2 bearings; Carriage weight = 1.8 lbs. (0,82 kg)
- └ x = 4; Carriage has 4 bearings; Carriage weight = 2.0 lbs. (0,91 kg)

### Footnotes:

(1) Weight shown is with a 0.625 inch (16 mm) diameter screw, a 2 bearing carriage [1.8 lbs (0,82 kg)], a NEMA 23 motor mount [0.34 lbs (0,16 kg)], and a C100 style [0.09 lbs (0,04 kg)] coupling. When using a 0.500 inch diameter screw subtract 0.022 lbs per inch (0,00039 kg per mm) of screw length for a given model number. When using a 4 bearing carriage add 0.2 lbs (0,09 kg) to each value.

## Dimensions

## - With Waycovers -

Made in the U.S.A.

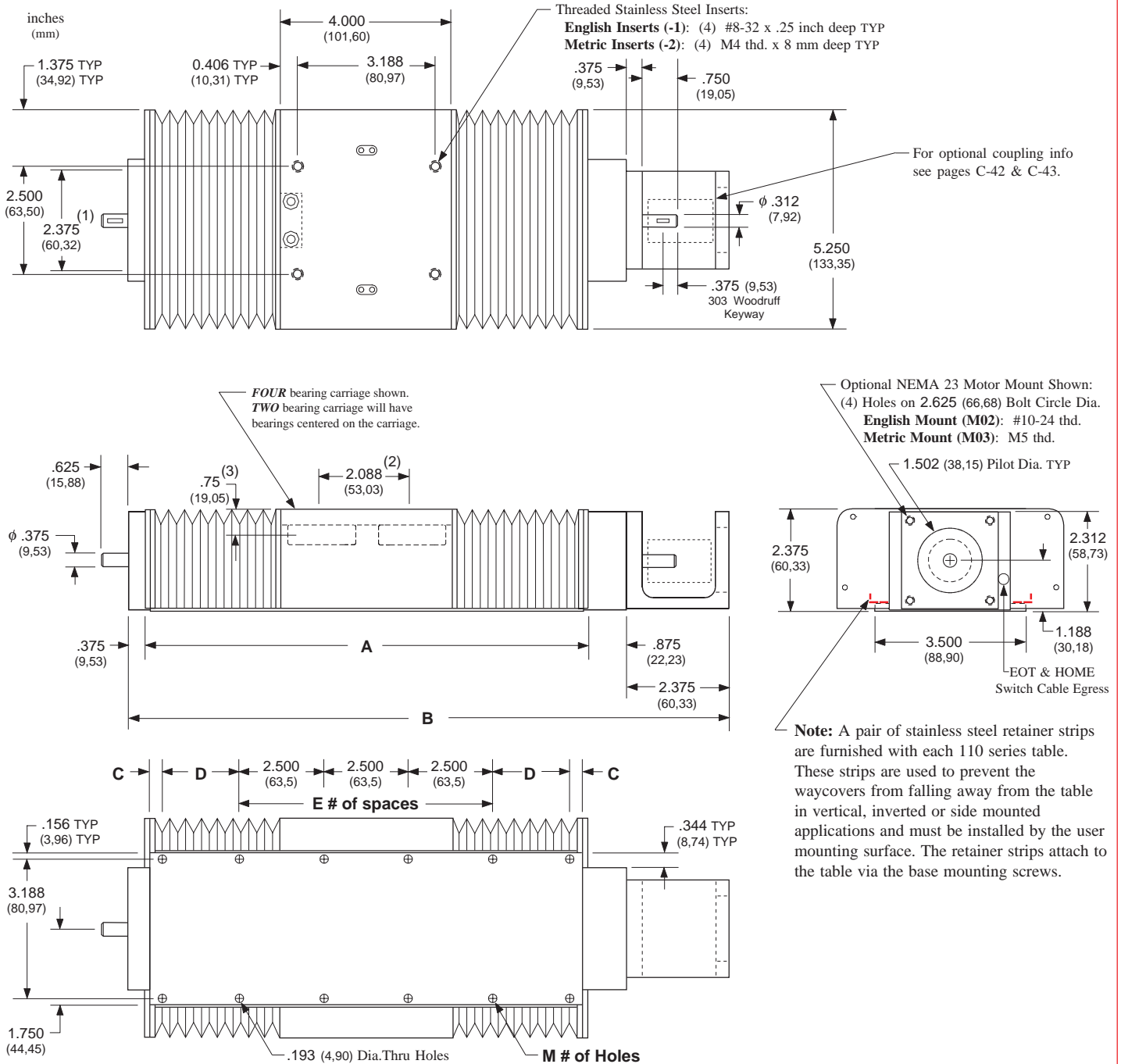

- (1) This value is center to center distance (spread) between the two rails ( $d_1$ ).
- (2) This value is center to center distance (spacing) of the bearings on a single rail ( $d_2$ ).
- (3) This value is center distance of the bearing to top of carriage plate surface ( $d_3$ ).

**Note:** Any 100, 110, 120 or 130 series table can be mounted on top of any second 100, 110, 120 series table by the user, in order to create X-Y multiple axis configurations. The 100-CP1, 100-CP2, or 120 series tables require one of the *Carriage Adapter Plate* options. The carriage's threaded stainless steel insert hole pattern exactly matches the base mounting hole pattern on each table, therefore no extra adapter bracket or machining is required. However a precision square tool, or micrometer depth gauge, is required in order to obtain an orthogonality between the two tables of < 30 arc-seconds. The table base, carriage top & carriage sides are all precision machined. *LINTECH's* 100 series, 4 bearing carriage, should be used for the bottom axis in a multiple axes application for better system rigidity, performance, and life.

**Thrust Capacity (axial load)**

The life of the screw end support bearings can be estimated by evaluating the applied axial (thrust) load. The applied load "as seen by the bearings" depends upon the table orientation. Typically, the extra force acting upon the bearings during the acceleration interval is offset by a reduction in force during the deceleration interval. Therefore, evaluating the life of the bearings at a constant speed is adequate. The life of the screw end support bearings may not be the limiting element for a given application. See page C-17 for load/life capacity of acme and ball screw nuts.

$$L = \left[ \frac{R}{F \times S} \right]^3 \times B$$

- B** = 2 (for millions of revolutions)
- E** = externally applied extra forces
- F** = applied axial load (*as seen by the bearings*)
- L** = calculated life (millions of revolutions)
- R** = dynamic load capacity of bearings at 2 million screw revolutions (see below)
- S** = safety factor (1 to 8)
- W** = user mounted load weight to carriage
- μ** = coefficient of friction for linear bearing system (0.01)

Horizontal Application

$$F = (W \times \mu) + E$$

Vertical Application

$$F = W + E$$

Screw End Supports		Number of Screw Revolutions						
		millions of screw revolutions						
		Static	1	2	10	50	100	500
Thrust Capacity	lbs (kg)	1,355 (615)	1,355 (615)	1,145 (519)	665 (302)	395 (179)	305 (138)	180 (82)

Note: Multiply screw revolutions by the screw lead in order to convert to inches (or mm) traveled by the nut.

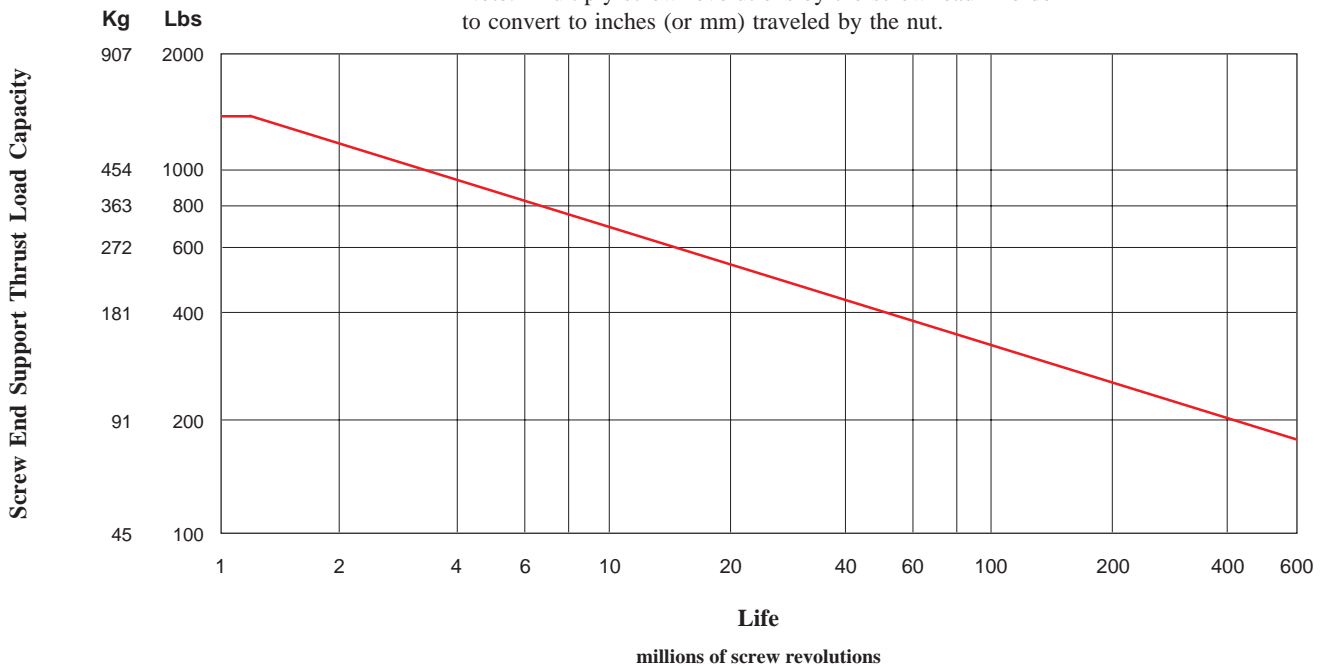

## Screw Travel Life

The life of an acme or ball screw can be estimated by evaluating the load applied to the nut. The applied load "as seen by the screw nut" depends upon the table orientation. Typically, the extra force acting upon the screw nut during the acceleration interval is offset by a reduction in force during the deceleration interval. Therefore, evaluating the life of the screw nut at a constant speed is adequate. The life of the screw nut may not be the limiting element for a given application. See page C-16 for load/life capacity of the screw end support bearings.

### Horizontal Application

$$F = (W \times \mu) + E$$

### Vertical Application

$$F = W + E$$

$$L = \left[ \frac{R}{F \times S} \right]^3 \times B$$

- B** = either 1 (for millions of inches) or 25 (for Km)
- E** = externally applied extra forces
- F** = applied axial load (*as seen by screw nut*)
- L** = calculated travel life (millions of inches or Km)
- R** = rated dynamic load capacity of screw nut at 1 million inches of travel or 25 Km (see pages C-20 to C-23)
- S** = safety factor (1 to 8)
- W** = user mounted load weight to carriage
- μ** = coefficient of friction for linear bearing system (0.01)

C

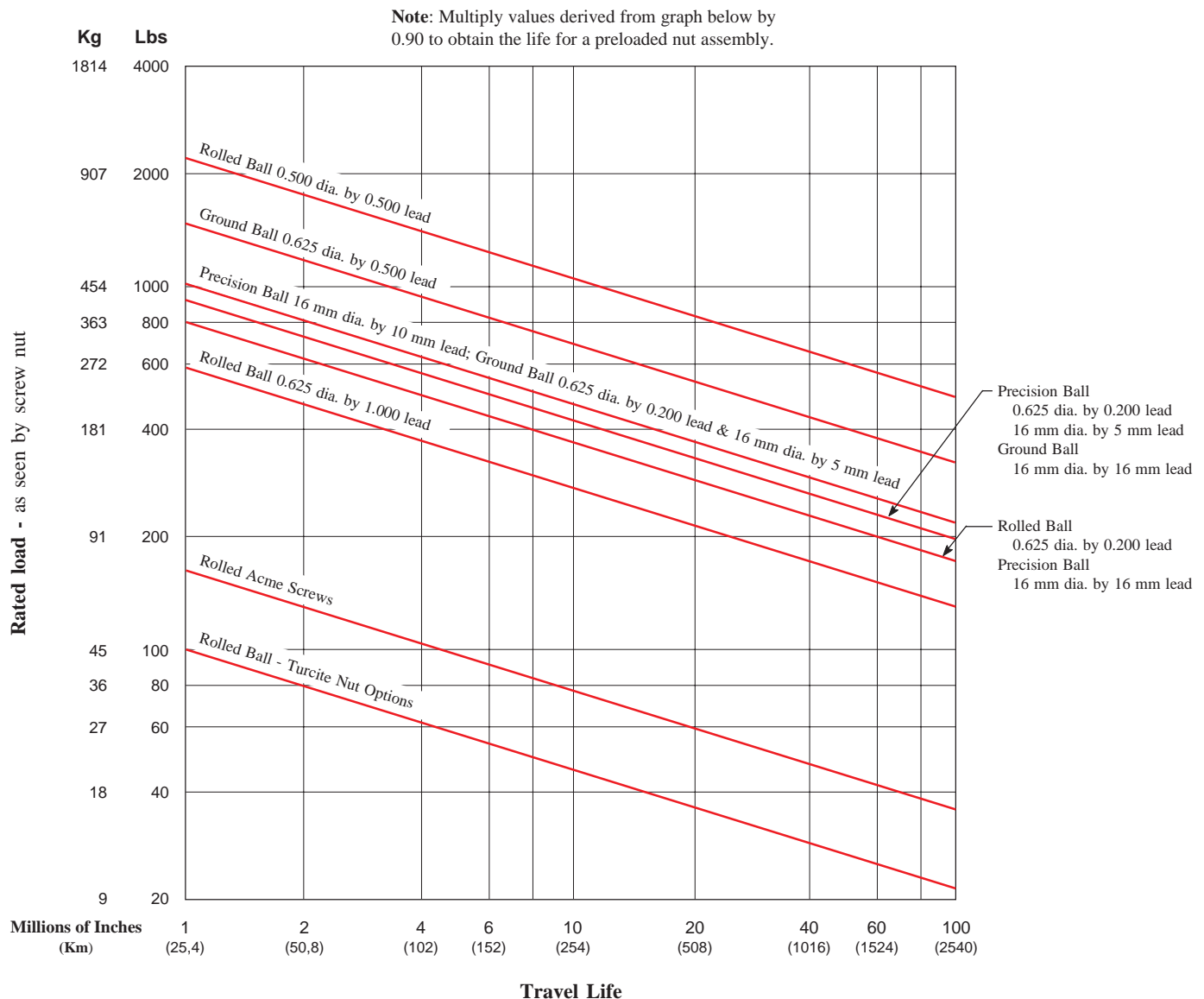

Specifications subject to change without notice

## Screws - Acme &amp; Ball

Acme screws use a turcite (polymer), or bronze nut. The nut threads ride in the matching acme screw threads, much like the ordinary nut and bolt system. This produces a higher friction (lower efficiency) system than a ball screw assembly, since there are no rolling elements between the nut and the acme screw threads. For applications requiring low speeds, noise and duty cycles, an acme screw works fine. Also, an acme screw is a good choice for most vertical applications, as it typically prevents back driving of the attached load.

Ball screws are the screw of choice for high duty cycle, high speed, and long life applications. The 100 & 110 series tables can be fitted with an assortment of ball screws. The ball screw nut uses one or more circuits of recirculating steel balls which roll between the nut and ball screw grooves, providing an efficient low friction system. Using a

higher lead ball screw (for example a 0.500 inch lead instead of a 0.200 inch lead) will offer greater carriage speed for applications requiring rapid traverse, or fast, short incremental moves. Low wear and long life are key features of a ball screw system.

*LINTECH* provides three different ball screw configurations. The rolled ball screw system utilizes a tapped nut with a standard accuracy grade rolled screw. The precision ball screw system utilizes a ground nut with a higher accuracy grade rolled screw. The ground ball screw system utilizes a ground nut with a high accuracy precision ground screw.

Some screws are available with preloaded nuts. The preloaded nut assembly offers high *bidirectional* repeatability by eliminating backlash.

Consideration	Acme Screw	Ball Screws			Comments
		Rolled	Precision	Ground	
<b>Audible noise</b>	least audible noise	most audible noise	less audible noise than rolled screw	less audible noise than precision screw	<b>Acme:</b> no rolling elements provide for quiet operation. <b>Ball:</b> recirculating balls in nut assembly transmit audible noise during motion; due to more accurate machining procedures - precision & ground ball screws are quieter than rolled ball screws.
<b>Back Driving Loads</b>	may prevent back driving	can easily back drive a load	can easily back drive a load	can easily back drive a load	<b>Acme:</b> good for light loads & vertical applications. <b>Ball:</b> recirculating balls in nut assembly produce a low friction system; vertical applications may require a brake to hold the load when no power is applied to the motor.
<b>Backlash non-preloaded nut</b>	will increase with wear	constant	constant	constant	<b>Acme:</b> preloaded nut assembly eliminates backlash. <b>Ball:</b> preloaded nut assembly eliminates backlash.
<b>Duty Cycle</b>	low to medium (< 50 %)	high (100 %)	high (100 %)	high (100 %)	<b>Acme:</b> low duty cycle due to high sliding friction. <b>Ball:</b> high duty cycle due to recirculating balls in nut assembly - high efficiency & low friction system.
<b>Life</b>	shorter due to higher friction	long	long	long	<b>Acme:</b> mechanical wear related to duty cycle, load & speed. <b>Ball:</b> minimal wear if operated in proper environment, within load specifications, and periodically lubricated.
<b>Relative - Cost</b>	slightly more than rolled ball	least expensive	slightly more than rolled ball	most expensive	<b>Acme:</b> a little more expensive than the rolled ball screw. <b>Ball:</b> due to more accurate manufacturing procedures precision rolled & ground ball screws are more expensive.
<b>Screw Efficiency</b>	low 40 % -Acme 60 % -Turcite	high (90 %)	high (90 %)	high (90 %)	<b>Acme:</b> low efficiency due to high sliding friction. <b>Ball:</b> high efficiency due to recirculating balls in nut assembly - low friction system.
<b>Smoothness</b>	can be smooth	least smooth	medium smoothness	smoothest	<b>Acme:</b> due to friction can start/stop at very low speeds. <b>Ball:</b> smoothness is constant through a wide speed range; due to more accurate manufacturing procedures precision rolled & ground ball screws are smoother than rolled ball screws.
<b>Speeds</b>	low	high	high	high	<b>Acme:</b> high friction can causes excess heat & wear at high speeds. <b>Ball:</b> recirculating balls in nut provide for a high speed system due to low friction & high efficiency.

## Screws - Acme &amp; Ball

100 Series Model Number	110 Series Model Number	Maximum Safe Table Operating Speed <sup>(1)</sup> in/sec (mm/sec)										
		Screw										
		0.500 dia. 0.500 lead	0.625 dia. 0.100 lead	0.625 dia. 0.200 lead	0.625 dia. 0.500 lead	0.625 dia. 1.000 lead	16 mm dia. 4 mm lead	16 mm dia. 5 mm lead	16 mm dia. 10 mm lead	16 mm dia. 16 mm lead		
Travel Length inches (mm)	Travel Length inches (mm)											
10x402	11x401	2 (50)	1.0 (50)	25.0 (635)	5.0 (127)	10.0 (254)	25.0 (635)	50.0 (1270)	7.9 (201)	9.8 (249)	19.7 (500)	31.5 (800)
10x404	11x402	4 (100)	2.5 (63)	25.0 (635)	5.0 (127)	10.0 (254)	25.0 (635)	50.0 (1270)	7.9 (201)	9.8 (249)	19.7 (500)	31.5 (800)
10x406	11x404	6 (150)	4.0 (100)	25.0 (635)	5.0 (127)	10.0 (254)	25.0 (635)	50.0 (1270)	7.9 (201)	9.8 (249)	19.7 (500)	31.5 (800)
10x408	11x405	8 (200)	5.5 (139)	25.0 (635)	5.0 (127)	10.0 (254)	25.0 (635)	50.0 (1270)	7.9 (201)	9.8 (249)	19.7 (500)	31.5 (800)
10x412	11x408	12 (300)	8.5 (215)	25.0 (635)	5.0 (127)	10.0 (254)	25.0 (635)	50.0 (1270)	7.9 (201)	9.8 (249)	19.7 (500)	31.5 (800)
10x416	11x411	16 (400)	11.5 (292)	25.0 (635)	5.0 (127)	10.0 (254)	25.0 (635)	50.0 (1270)	7.9 (201)	9.8 (249)	19.7 (500)	31.5 (800)
10x420	11x414	20 (500)	14.3 (365)	21.5 (546)	5.0 (127)	10.0 (254)	25.0 (635)	50.0 (1270)	7.9 (201)	9.8 (249)	19.7 (500)	31.5 (800)
10x424	11x417	24 (600)	17.3 (441)	16.1 (409)	4.2 (107)	8.4 (213)	21.0 (533)	41.9 (1064)	6.5 (165)	8.2 (208)	16.4 (416)	26.2 (665)
10x430	11x422	30 (760)	22.0 (558)	11.2 (284)	2.9 (74)	5.8 (147)	14.5 (368)	29.0 (737)	4.5 (114)	5.6 (142)	11.3 (287)	18.1 (460)
10x436	11x428	36 (910)	28.0 (711)	8.2 (208)	2.1 (53)	4.2 (107)	10.6 (269)	21.3 (541)	3.3 (84)	4.1 (104)	8.3 (211)	13.3 (338)
10x442	11x431	42 (1060)	31.7 (806)	6.2 (157)	1.6 (41)	3.3 (81)	8.1 (206)	16.3 (414)	2.5 (63)	3.2 (81)	6.3 (160)	10.1 (257)
10x448	11x436	48 (1210)	36.3 (923)	4.9 (124)	1.3 (33)	2.5 (63)	6.4 (162)	12.8 (325)	2.0 (51)	2.5 (63)	5.0 (127)	8.0 (203)
10x454	11x440	54 (1370)	40.7 (1035)	4.0 (102)	1.0 (25)	2.0 (51)	5.2 (132)	10.4 (264)	1.6 (41)	2.0 (51)	4.0 (102)	6.5 (165)
10x460	11x445	60 (1520)	45.5 (1155)	3.3 (84)	0.8 (20)	1.7 (43)	4.3 (109)	8.6 (218)	1.3 (33)	1.7 (43)	3.3 (84)	5.3 (135)

## Footnotes:

- (1) These listed speeds are a mechanical limitation. The maximum speed of a positioning table depends on the screw diameter, screw lead, screw length, and the screw end bearing support configuration. *LINTECH* uses a fixed-simple screw end bearing support configuration in its positioning tables. The correct motor & drive system needs to be selected in order to obtain the above maximum table speeds.

## Screws - Acme &amp; Ball

SCREW	ROLLED BALL SCREWS							
	Dyn. <sup>(1)</sup> Capacity lbs (kg)	Static Capacity lbs (kg)	Screw Efficiency %	Breakaway Torque oz-in (N-m)	Position Accuracy inch/ft (microns/300 mm)	Backlash inches (microns)	Unidirectional Repeatability inches (microns)	Bidirectional Repeatability inches (microns)
0.500 inch dia. 0.500 inch lead	<i>Non-preloaded</i> (S001)	2,200 (997)	13,350 (6055)	90	15 (0,11)	< 0.003 (75)	< 0.008 (203)	+ 0.0002 to - 0.0082 (5) (208)
	<sup>(2)</sup> <i>Preloaded</i> (S002)	1,980 (898)	13,130 (5955)		30 (0,21)			
	<i>Non-preloaded</i> Turcite Nut (S003)	100 (45)	800 (363)	60	25 (0,18)	< 0.008 (203)	+ 0.0002 to - 0.0082 (5) (208)	
	<i>Preloaded</i> Turcite Nut (S004)	90 (41)	800 (363)		40 (0,28)	0	+ 0.0002 to - 0.0002 (5) (5)	
0.625 inch dia. 0.200 inch lead	<i>Non-preloaded</i> (S005)	800 (363)	6,150 (2790)	90	10 (0,07)	< 0.003 (75)	< 0.008 (203)	+ 0.0002 to - 0.0082 (5) (208)
	<i>Preloaded</i> (S006)	720 (326)	6,070 (2753)		20 (0,14)			
	<i>Non-preloaded</i> Turcite Nut (S007)	100 (45)	800 (363)	60	15 (0,11)	< 0.008 (203)	+ 0.0002 to - 0.0082 (5) (208)	
	<i>Preloaded</i> Turcite Nut (S008)	90 (41)	800 (363)		30 (0,21)	0	+ 0.0002 to - 0.0002 (5) (5)	
0.625 inch dia. 1.000 inch lead	<i>Non-preloaded</i> (S009)	590 (267)	2,425 (1100)	90	25 (0,18)	< 0.004 (100)	< 0.008 (203)	+ 0.0002 to - 0.0082 (5) (208)
	<i>Preloaded</i> (S010)	530 (240)	2,390 (1084)		40 (0,28)			
	<i>Non-preloaded</i> Turcite Nut (S011)	100 (45)	800 (363)	60	35 (0,25)	< 0.008 (203)	+ 0.0002 to - 0.0082 (5) (208)	
	<i>Preloaded</i> Turcite Nut (S012)	90 (41)	800 (363)		60 (0,42)	0	+ 0.0002 to - 0.0002 (5) (5)	

## Footnotes:

- (1) Dynamic load capacity of screw based on 1 million inches of travel (25Km).
- (2) There is a 2.2 inch (55,9 mm) reduction of carriage travel (from the listed travel) when using a preloaded nut with this screw option for the 100 series. For the 110 series 1 inch listed travel (this option is not available), for the 2.5 inch listed travel (reduction of travel to 1.0 inch), for the 4 inch listed travel (reduction of travel to 2.75 inches), for the 5.5 inch listed travel (reduction of travel to 4.5 inches), for the 8.0 inch listed travel (reduction of travel to 7.75 inches).

## Screws - Acme &amp; Ball

SCREW	PRECISION BALL SCREWS								
	Dyn. <sup>(1)</sup> Capacity	Static Capacity	Screw Efficiency	Breakaway Torque	Position Accuracy	Backlash	Unidirectional Repeatability	Bidirectional Repeatability	
	lbs (kg)	lbs (kg)	%	oz-in (N-m)	inch/ft (microns/300 mm)	inches (microns)	inches (microns)	inches (microns)	
0.625 inch dia. 0.200 inch lead	<i>Non-preloaded</i> (S114)	876 (397)	2,700 (1224)	90	10 (0,07)	< 0.002 (50)	< 0.003 (76)	+/- 0.0002 (5)	+ 0.0002 to - 0.0032 (5) (81)
	<i>Preloaded</i> (S115)	788 (357)	2,430 (1102)		20 (0,14)		0		+ 0.0002 to - 0.0002 (5) (5)
16 mm dia. 5 mm lead	<i>Non-preloaded</i> (S116)	876 (397)	2,700 (1224)	90	10 (0,07)	< 0.002 (50)	< 0.003 (76)	+/- 0.0002 (5)	+ 0.0002 to - 0.0032 (5) (81)
	<i>Preloaded</i> (S117)	788 (357)	2,430 (1102)		20 (0,14)		0		+ 0.0002 to - 0.0002 (5) (5)
16 mm dia. 10 mm lead	<i>Non-preloaded</i> (S118)	1,080 (489)	2,630 (1192)	90	15 (0,11)	< 0.002 (50)	< 0.003 (76)	+/- 0.0002 (5)	+ 0.0002 to - 0.0032 (5) (81)
	<sup>(2)</sup> <i>Preloaded</i> (S119)	972 (440)	2,365 (1072)		25 (0,18)		0		+ 0.0002 to - 0.0002 (5) (5)
16 mm dia. 16 mm lead	<i>Non-preloaded</i> (S120)	819 (371)	1,620 (734)	90	20 (0,14)	< 0.002 (50)	< 0.003 (76)	+/- 0.0002 (5)	+ 0.0002 to - 0.0032 (5) (81)
	<sup>(3)</sup> <i>Preloaded</i> (S121)	737 (334)	1,455 (659)		35 (0,24)		0		+ 0.0002 to - 0.0002 (5) (5)

## Footnotes:

- (1) Dynamic load capacity of screw based on 1 million inches of travel (25Km).
- (2) There is a 0.5 inch (12,7 mm) reduction of carriage travel (from the listed travel length) when using a preloaded nut with this screw option for the 100 series.
- (3) There is a 0.7 inch (17,8 mm) reduction of carriage travel (from the listed travel length) when using a preloaded nut with this screw option for the 100 series.

## Screws - Acme &amp; Ball

SCREW	GROUND BALL SCREWS <sup>(2)</sup>							
	Dyn. <sup>(1)</sup> Capacity lbs (kg)	Static Capacity lbs (kg)	Screw Efficiency %	Breakaway Torque oz-in (N-m)	Position Accuracy inch/ft (microns/300 mm)	Backlash inches (microns)	Unidirectional Repeatability inches (microns)	Bidirectional Repeatability inches (microns)
<b>0.625 dia., 0.200 lead</b> <i>Preloaded</i> (S212)	987 (447)	3,080 (1397)	90	20 (0,14)	< 0.0012 (30)	0	+/- 0.0001 (2,5)	+ 0.0001 to - 0.0001 (2,5) (2,5)
<b>0.625 dia., 0.500 lead</b> <i>Preloaded</i> (S213)	1430 (649)	4,191 (1901)	90	30 (0,21)	< 0.0012 (30)	0	+/- 0.0001 (2,5)	+ 0.0001 to - 0.0001 (2,5) (2,5)
<b>16 mm dia., 5 mm lead</b> <i>Preloaded</i> (S214)	987 (447)	3,080 (1397)	90	20 (0,14)	< 0.0012 (30)	0	+/- 0.0001 (2,5)	+ 0.0001 to - 0.0001 (2,5) (2,5)
<b>16 mm dia., 16 mm lead</b> <i>Preloaded</i> (S215)	910 (412)	1,800 (816)	90	35 (0,24)	< 0.0012 (30)	0	+/- 0.0001 (2,5)	+ 0.0001 to - 0.0001 (2,5) (2,5)

## Footnotes:

(1) Dynamic load capacity of screw based on 1 million inches of travel (25Km).

(2) The Ground Ball Screw options are only available in travel lengths up to 36 inches for the 100 series and up to 28 inches of travel for the 110 series.

## Screws - Acme &amp; Ball

SCREW	ROLLED ACME SCREWS								
	Dyn. <sup>(1)</sup> Capacity	Static Capacity	Screw Efficiency	Breakaway Torque	Position Accuracy	Backlash	Unidirectional Repeatability	Bidirectional Repeatability	
	lbs (kg)	lbs (kg)	%	oz-in (N-m)	inch/ft (microns/300 mm)	inches (microns)	inches (microns)	inches (microns)	
0.625 inch dia. 0.100 inch lead	<i>Non-preloaded</i> (S300)	160 (73)	800 (363)	40	10 (0,07)	< 0.003 (75)	< 0.008 (203)	+/- 0.0002 (5)	+ 0.0002 to - 0.0082 (5) (208)
	<i>Preloaded</i> (S301)	140 (64)	720 (327)		20 (0,14)		0		+ 0.0002 to - 0.0002 (5) (5)
0.625 inch dia. 0.200 inch lead	<i>Non-preloaded</i> (S302)	160 (73)	800 (363)	40	15 (0,11)	< 0.003 (75)	< 0.008 (203)	+/- 0.0002 (5)	+ 0.0002 to - 0.0082 (5) (208)
	<i>Preloaded</i> (S303)	140 (64)	720 (327)		30 (0,21)		0		+ 0.0002 to - 0.0002 (5) (5)
16 mm dia. 4 mm lead	<i>Non-preloaded</i> (S304)	160 (73)	800 (363)	40	15 (0,11)	< 0.003 (75)	< 0.008 (203)	+/- 0.0002 (5)	+ 0.0002 to - 0.0082 (5) (208)
	<i>Preloaded</i> (S305)	140 (64)	720 (327)		30 (0,21)		0		+ 0.0002 to - 0.0002 (5) (5)

## Footnotes:

(1) Dynamic load capacity of screw based on 1 million inches of travel (25Km).

### Single or Multiple Axis

*LINTECH's* 120 series positioning tables offer precision performance and design flexibility for use in a wide variety of Motion Control applications.

- *Welding*
- *Test Stands*
- *Part Insertion*
- *Laser Positioning*
- *Liquid Dispensing*
- *Semiconductor Processing*
- *Gluing*
- *Pick & Place*
- *Part Scanning*
- *Inspection Stations*
- *General Automation*

### Quality Construction

*LINTECH's* 120 series tables are designed to handle light loads at very high speeds. These tables use a low friction, preloaded, recirculating linear ball bearing system, which rides on precision ground linear rails. The linear rails are mounted to a precision machined aluminum base, which offers a rigid support over the entire travel of the table's carriage. The load is mounted to a precision machined aluminum carriage, which has threaded stainless steel inserts for high strength and wear life. The drive system uses two pulleys, along with a high strength, steel reinforced polyurethane belt, which provides 3.543 inches (90 mm) of linear movement per revolution of the input shaft. The simple belt tensioning system allows for easy adjustment of belt tension by the user. NEMA 23 & 34 motor mounts, or gearhead mounts are available as well as planetary gearheads.

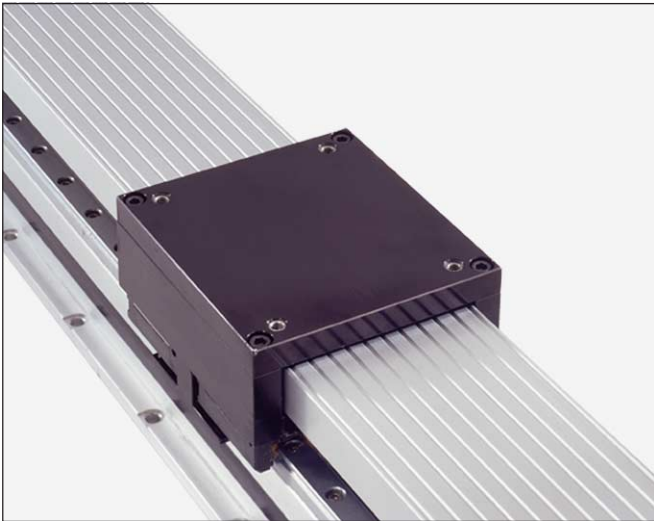

### Available Options

#### Carriage Adapter Plates & Vertical Angle Brackets

Optional carriage adapter plates and vertical angle brackets can be mounted directly to the top of various *LINTECH* positioning tables, thus providing for easy multiple axis configurations.

#### End of Travel and Home Switches

The 120 series tables can be provided with end of travel (EOT) and home switches mounted and wired for each axis. Most position controllers can utilize the EOT switches to stop carriage motion when the extreme table travel has been reached in either direction. The home switch provides a known mechanical location on the table.

#### Motor Adapter Brackets

NEMA 34 or any metric mount motor can be mounted to a 120 series positioning table with the use of adapter brackets.

#### Rotary Encoders

Incremental rotary encoders can be mounted to the table in order to provide positional data back to either a motion controller, or a digital display.

#### Planetary Gearheads

*LINTECH* provides planetary gearheads which can be used with a 120 series. These gearheads are provided in either an in-line or right angle version, with standard gear ratios of 1:1, 2:1 & 3:1. Gearheads may be required for applications which have a large mismatch of load to motor inertias. They also help reduce the torque required from the motor for a particular application.

#### Other

The 120 series tables can accommodate **chrome plated linear bearings & rails** for corrosive environment applications and **power-off electric brakes** for load locking applications.

**Standard Features - 120 Series**

- ❑ Compact 3.500 inches (89 mm) wide by 3.000 inches (76 mm) tall
- ❑ Travel lengths from 4 inches (100 mm) to 10 feet (3,0 meters)
- ❑ Threaded stainless steel inserts in carriage for load mounting
- ❑ Polyurethane belt with high strength steel tension members
- ❑ 0° F to +176° F (-18° C to +80° C) operating temperature
- ❑ Single screw belt tensioning with self locking thread
- ❑ Dynamic Load Capacity to 3,100 lbs (1406 kg)
- ❑ Recirculating linear ball bearing system
- ❑ Precision ground square rail design
- ❑ 2 rails, 2 or 4 bearing carriages

C

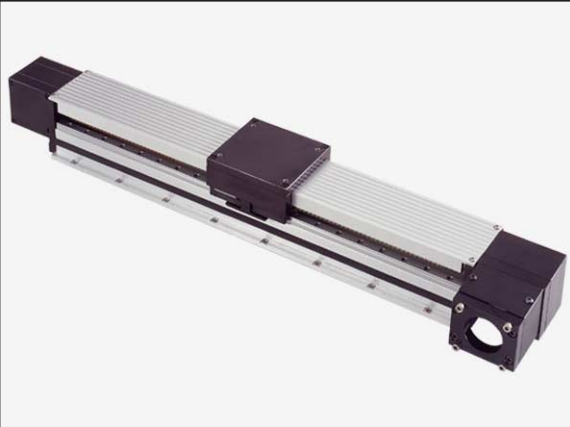
**120 Series****Options - 120 Series**

- ❑ End of travel (EOT) and home switches wired
- ❑ AUTOCAD® drawings available upon request
- ❑ Adapter brackets for non-NEMA motors
- ❑ Chrome plated linear bearings & rails
- ❑ Rotary incremental encoders
- ❑ NEMA 34 adapter bracket
- ❑ Power-off electric brakes
- ❑ Carriage adapter plates
- ❑ Vertical angle bracket
- ❑ Planetary gearheads
- ❑ Motor couplings

**12** - **4** - **4** - **004** - **CP1** - **1** - **D1** - **M02** - **C155** - **L04** - **E00** - **B00**

**Table Series**

**Number of Bearings**

- 2 - 2 bearing per carriage
- 4 - 4 bearings per carriage

**Carriage Length**

- 4 - 4 inches

**Travel Length** (see pages C-28 & C-30)

- 004 - 4 to 120 inches

**Cover Plate**

- CP0 - no cover plate
- CP1 - top cover plate only

**Carriage Inserts** (see pages C-29 & C-31)

- 1 - English mount
- 2 - Metric mount

**Drive Shaft** (see pages C-29 & C-31)

- D1 - Right Hand single shaft
- D2 - Left Hand single shaft
- D3 - Right Hand thru shaft
- D4 - Left Hand thru shaft

**Motor Mount** (see pages C-29, C-31 & C-48)

- M00 - none
- M99 - other
- M02 - NEMA 23 mount (E)
- M03 - NEMA 23 mount (M)
- M04 - NEMA 34 mount (E)
- M05 - NEMA 34 mount (M)

**Coupling Options** (see pages C-42 & C-43)

- C000 - none
- C999 - none
- C130 to C134 - H100
- C155 to C164 - H131
- C190 to C200 - H163
- C407 to C413 - G100
- C435 to C444 - G126
- C470 to C480 - G158

**Limit & Home Switches** (see pages C-39 to C-41)

- |                   |                     |      |      |            |            |
|-------------------|---------------------|------|------|------------|------------|
| L00 - no switches |                     | Reed | Hall | Prox (NPN) | Prox (PNP) |
| L99 - other       | EOT & home switches | L04  | L07  | L10        | L13        |
|                   | EOT switches only   | L05  | L08  | L11        | L14        |
|                   | home switch only    | L06  | L09  | L12        | L15        |

**Encoder Options** (see page C-51)

- E00 - none
- E01 - rotary (500 lines/rev)
- E02 - rotary (1000 lines/rev)
- E03 - rotary (1270 lines/rev)
- E99 - other

*note: When selecting any rotary encoder option, the Drive Shaft D3 or D4 above is required.*

**Power-off Brakes** (see page C-50)

- B00 - none
- B01 - 24 VDC
- B02 - 90 VDC
- B99 - other

*note: When selecting any brake option, the Drive Shaft D3 or D4 above is required.*

(E) - English Interface  
(M) - Metric Interface

## Specifications

Made in the U.S.A.

Load Capacities		Two (2) Bearing Carriage		Four (4) Bearing Carriage	
<b>Dynamic Horizontal</b>	2 million inches (50 km) of travel	1,550 lbs	( 703 kg)	3,100 lbs	( 1406 kg)
<b>Dynamic Horizontal</b>	50 million inches (1270 km) of travel	525 lbs	( 238 kg)	1,060 lbs	( 480 kg)
<b>Static Horizontal</b>		2,360 lbs	( 1070 kg)	4,720 lbs	( 2140 kg)
<b>Dynamic Roll Moment</b>	2 million inches (50 km) of travel	140 ft-lbs	( 190 N-m)	280 ft-lbs	( 379 N-m)
<b>Dynamic Roll Moment</b>	50 million inches (1270 km) of travel	47 ft-lbs	( 64 N-m)	95 ft-lbs	( 129 N-m)
<b>Static Roll Moment</b>		210 ft-lbs	( 285 N-m)	425 ft-lbs	( 576 N-m)
<b>Dyn. Pitch &amp; Yaw Moment</b>	2 million inches (50 km) of travel	18 ft-lbs	( 24 N-m)	240 ft-lbs	( 325 N-m)
<b>Dyn. Pitch &amp; Yaw Moment</b>	50 million inches (1270 km) of travel	6 ft-lbs	( 8 N-m)	82 ft-lbs	( 111 N-m)
<b>Static Pitch &amp; Yaw Moment</b>		30 ft-lbs	( 41 N-m)	365 ft-lbs	( 495 N-m)
<b>Each Bearing Dyn. Capacity</b>	2 million inches (50 km) of travel	775 lbs	( 351 kg)	775 lbs	( 351 kg)
<b>Each Bearing Dyn. Capacity</b>	50 million inches (1270 km) of travel	263 lbs	( 119 kg)	263 lbs	( 119 kg)
<b>Each Bearing Static Load Capacity</b>		1,180 lbs	( 535 kg)	1,180 lbs	( 535 kg)
<b>Maximum Belt Tensile Force</b>		250 lbs	( 113 kg)	250 lbs	( 113 kg)
<b>Maximum Carriage Thrust Force</b>		115 lbs	( 52 kg)	115 lbs	( 52 kg)
<b>Maximum Speed</b>		118 in/sec	( 3 m/sec)	118 in/sec	( 3 m/sec)
<b>Maximum Acceleration</b>		386 in/sec <sup>2</sup>	( 9,8 m/sec <sup>2</sup> )	772 in/sec <sup>2</sup>	( 19,6 m/sec <sup>2</sup> )
<b>d<sub>1</sub></b>	Center to center distance (spread) between the two rails	2.375 in	( 60,3 mm)	2.375 in	( 60,3 mm)
<b>d<sub>2</sub></b>	Center to center distance (spacing) of the bearings on a single rail		-	2.088 in	( 53,0 mm)
<b>d<sub>r</sub></b>	Center distance of the bearing to top of carriage plate surface	1.375 in	( 34,9 mm)	1.375 in	( 34,9 mm)

Other	For Two (2) & Four (4) Bearing Carriages
<b>Table Material</b>	Base, Carriage, End Plates, & Cover Plate - 6061 anodized aluminum
<b>Linear Rail Material</b>	Case Hardened Steel
<b>Belt Properties</b>	Black, 16 mm wide, Polyurethane, Steel reinforced belt
<b>Drive Pulley Weight</b>	0.21 lbs ( 0,10 kg)
<b>Drive Pulley Diameter</b>	1.128 in ( 28,65 mm)
<b>Drive Lead</b>	3.543 in ( 90,00 mm)
<b>Belt Stretch - x Load (lbs or N)</b>	0.00025 in/ft per lbs ( 0,00476 mm/m per N)
<b>Unidirectional Repeatability</b>	+/- 0.001 in (+/- 0,0254 mm)
<b>Bidirectional Repeatability</b>	+/- 0.004 in (+/- 0,1016 mm)
<b>Position Accuracy (Belt) <sup>(1)</sup></b>	< 0.010 in/ft (< 0,254 mm/300mm)
<b>Orthogonality (multi-axis systems)</b>	< 30 arc-seconds
<b>Friction Coefficient</b>	< 0.01
<b>Breakaway Torque</b>	< 60 oz-in (0,424 N-m)
<b>Motor Mount</b>	NEMA 23 & 34 Mounts, Metric Mounts, and Gearheads
<b>Coupling</b>	Two (2) different styles available

### Footnotes:

(1) Position accuracy varies based on belt stretch. The given rating is based upon a carriage speed of 5 inches/sec (127 mm/sec) and a no load condition.

## Dimensions & Specifications

- Without Cover Plates -

Made in the U.S.A.

Model Number	Travel Length inches (mm)	Table Dimensions inches (mm)		Mounting Dimensions inches (mm)				Belt Weight ounces (gm)	Table <sup>(1)</sup> Weight lbs (kg)
		A	B	C	D	E	M		
<b>12x4004-CP0</b>	4 (100)	8.0 (203,2)	14.000 (355,6)	0.250 (6,3)	2.500 (63,5)	1	8	1.3 (36,8)	8.4 (3,8)
<b>12x4006-CP0</b>	6 (150)	10.0 (254,0)	16.000 (406,4)	1.250 (31,7)	2.500 (63,5)	1	8	1.5 (42,5)	9.1 (4,1)
<b>12x4008-CP0</b>	8 (200)	12.0 (304,8)	18.000 (457,2)	0.250 (6,3)	2.000 (50,8)	3	12	1.7 (48,2)	9.8 (4,4)
<b>12x4012-CP0</b>	12 (300)	16.0 (406,4)	22.000 (558,8)	0.250 (6,3)	1.500 (38,1)	5	16	2.1 (59,5)	11.1 (5,0)
<b>12x4016-CP0</b>	16 (400)	20.0 (508,0)	26.000 (660,4)	1.250 (31,7)	2.500 (63,5)	5	16	2.5 (70,9)	12.4 (5,6)
<b>12x4020-CP0</b>	20 (500)	24.0 (609,6)	30.000 (762,0)	0.750 (19,0)	2.500 (63,5)	7	20	2.9 (82,2)	13.7 (6,2)
<b>12x4024-CP0</b>	24 (600)	28.0 (711,2)	34.000 (863,6)	0.250 (6,3)	2.500 (63,5)	9	24	3.3 (93,6)	15.1 (6,8)
<b>12x4030-CP0</b>	30 (760)	34.0 (863,6)	40.000 (1016,0)	0.750 (19,0)	2.500 (63,5)	11	28	3.9 (110,6)	17.1 (7,8)
<b>12x4036-CP0</b>	36 (910)	40.0 (1016,0)	46.000 (1168,4)	1.250 (31,7)	2.500 (63,5)	13	32	4.5 (127,6)	19.1 (8,7)
<b>12x4042-CP0</b>	42 (1060)	46.0 (1168,4)	52.000 (1320,8)	1.750 (44,4)	2.500 (63,5)	15	36	5.1 (144,6)	21.1 (9,6)
<b>12x4048-CP0</b>	48 (1210)	52.0 (1320,8)	58.000 (1473,2)	2.250 (57,1)	2.500 (63,5)	17	40	5.7 (161,6)	23.1 (10,4)
<b>12x4054-CP0</b>	54 (1370)	58.0 (1473,2)	64.000 (1625,6)	0.250 (6,3)	2.500 (63,5)	21	48	6.3 (178,6)	25.1 (11,4)
<b>12x4060-CP0</b>	60 (1520)	64.0 (1625,6)	70.000 (1778,0)	0.750 (19,0)	2.500 (63,5)	23	52	6.9 (195,6)	27.1 (12,3)
<b>12x4072-CP0</b>	72 (1820)	76.0 (1930,4)	82.000 (2082,8)	1.750 (44,4)	2.500 (63,5)	27	60	8.1 (229,6)	31.1 (14,1)
<b>12x4084-CP0</b>	84 (2130)	88.0 (2235,2)	94.000 (2387,6)	0.250 (6,3)	2.500 (63,5)	33	72	9.3 (263,7)	35.1 (15,9)
<b>12x4096-CP0</b>	96 (2435)	100.0 (2540,0)	106.000 (2692,4)	1.250 (31,7)	2.500 (63,5)	37	80	10.5 (297,7)	39.1 (17,7)
<b>12x4108-CP0</b>	108 (2740)	112.0 (2844,8)	118.000 (2997,2)	2.250 (57,1)	2.500 (63,5)	41	88	11.7 (331,7)	43.1 (19,6)
<b>12x4120-CP0</b>	120 (3045)	124.0 (3149,6)	130.000 (3302,0)	0.750 (19,0)	2.500 (63,5)	47	100	12.9 (365,7)	47.1 (21,4)

- ┌ x = 2; Carriage has 2 bearings; Carriage weight = 1.6 lbs. (0,73 kg)
- └ x = 4; Carriage has 4 bearings; Carriage weight = 1.8 lbs. (0,82 kg)

### Footnotes:

(1) Weight shown is with a 2 bearing carriage [1.6 lbs (0,73 kg)], a NEMA 23 motor mount [0.34 lbs (0,16 kg)], and a H100 style [0.08 lbs (0,04 kg)] coupling. When using a 4 bearing carriage add 0.2 lbs (0,09 kg) to each value.

## Dimensions

### - Without Cover Plates -

Made in the U.S.A.

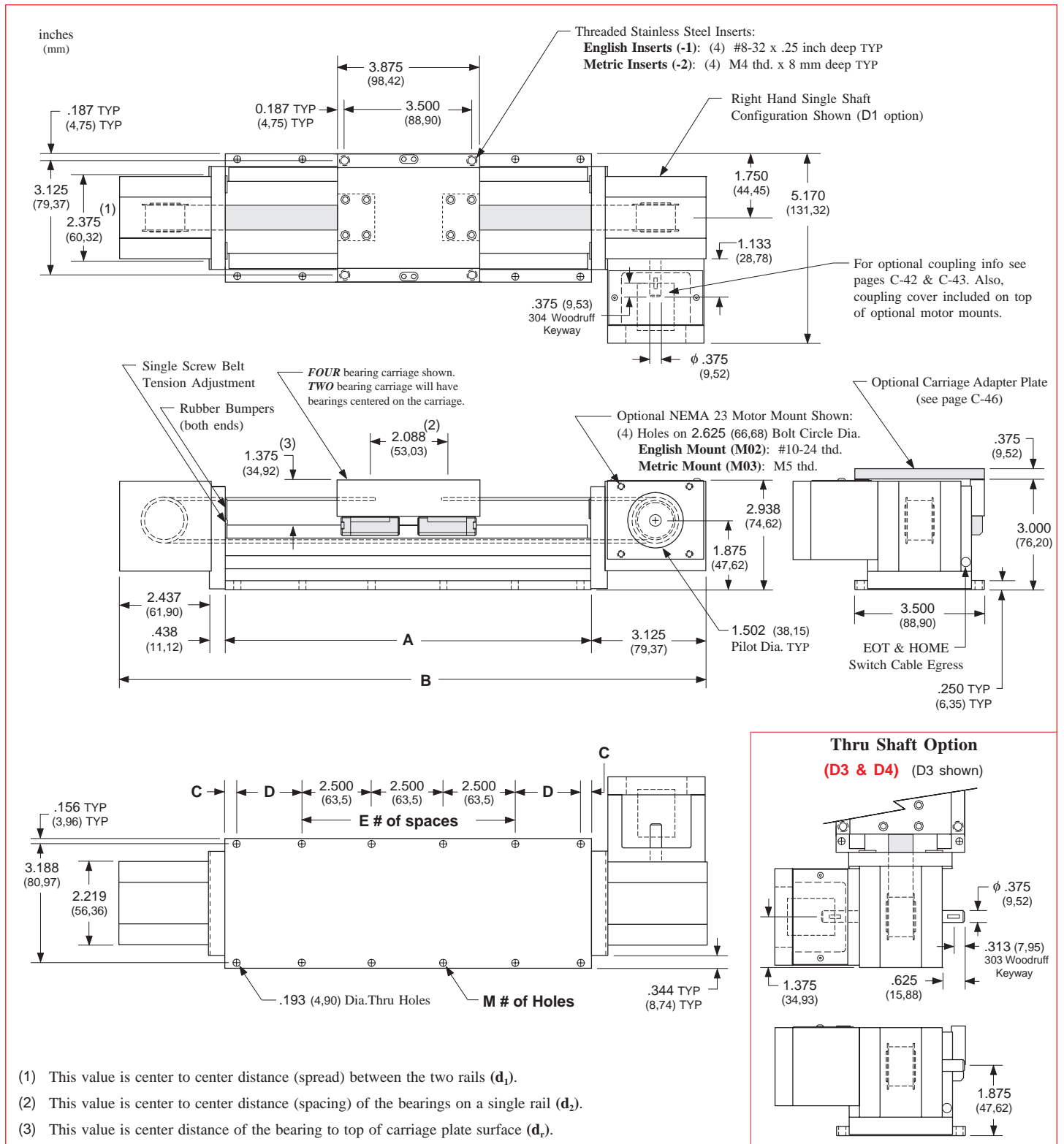

**Note:** Any 100, 110, 120 or 130 series table can be mounted on top of any second 100, 110, 120 series table by the user, in order to create X-Y multiple axis configurations. The 100-CP1, 100-CP2, or 120 series tables require one of the *Carriage Adapter Plate* options. The carriage's threaded stainless steel insert hole pattern exactly matches the base mounting hole pattern on each table, therefore no extra adapter bracket or machining is required. However a precision square tool, or micrometer depth gauge, is required in order to obtain an orthogonality between the two tables of < 30 arc-seconds. The table base, carriage top & carriage sides are all precision machined. *LINTECH's* 100 series, 4 bearing carriage, should be used for the bottom axis in a multiple axes application for better system rigidity, performance, and life.

## Dimensions & Specifications

- With Top Cover Plate Only -

Made in the U.S.A.

Model Number	Travel Length inches (mm)	Table Dimensions inches (mm)		Mounting Dimensions inches (mm)				Belt Weight ounces (gm)	Table Weight lbs (kg)
		A	B	C	D	E	M		
<b>12x4004-CP1</b>	4 (100)	8.0 (203,2)	14.000 (355,6)	0.250 (6,3)	2.500 (63,5)	1	8	1.3 (36,8)	8.4 (3,8)
<b>12x4006-CP1</b>	6 (150)	10.0 (254,0)	16.000 (406,4)	1.250 (31,7)	2.500 (63,5)	1	8	1.5 (42,5)	9.1 (4,1)
<b>12x4008-CP1</b>	8 (200)	12.0 (304,8)	18.000 (457,2)	0.250 (6,3)	2.000 (50,8)	3	12	1.7 (48,2)	9.8 (4,4)
<b>12x4012-CP1</b>	12 (300)	16.0 (406,4)	22.000 (558,8)	0.250 (6,3)	1.500 (38,1)	5	16	2.1 (59,5)	11.1 (5,0)
<b>12x4016-CP1</b>	16 (400)	20.0 (508,0)	26.000 (660,4)	1.250 (31,7)	2.500 (63,5)	5	16	2.5 (70,9)	12.4 (5,6)
<b>12x4020-CP1</b>	20 (500)	24.0 (609,6)	30.000 (762,0)	0.750 (19,0)	2.500 (63,5)	7	20	2.9 (82,2)	13.7 (6,2)
<b>12x4024-CP1</b>	24 (600)	28.0 (711,2)	34.000 (863,6)	0.250 (6,3)	2.500 (63,5)	9	24	3.3 (93,6)	15.1 (6,8)
<b>12x4030-CP1</b>	30 (760)	34.0 (863,6)	40.000 (1016,0)	0.750 (19,0)	2.500 (63,5)	11	28	3.9 (110,6)	17.1 (7,8)
<b>12x4036-CP1</b>	36 (910)	40.0 (1016,0)	46.000 (1168,4)	1.250 (31,7)	2.500 (63,5)	13	32	4.5 (127,6)	19.1 (8,7)
<b>12x4042-CP1</b>	42 (1060)	46.0 (1168,4)	52.000 (1320,8)	1.750 (44,4)	2.500 (63,5)	15	36	5.1 (144,6)	21.1 (9,6)
<b>12x4048-CP1</b>	48 (1210)	52.0 (1320,8)	58.000 (1473,2)	2.250 (57,1)	2.500 (63,5)	17	40	5.7 (161,6)	23.1 (10,4)
<b>12x4054-CP1</b>	54 (1370)	58.0 (1473,2)	64.000 (1625,6)	0.250 (6,3)	2.500 (63,5)	21	48	6.3 (178,6)	25.1 (11,4)
<b>12x4060-CP1</b>	60 (1520)	64.0 (1625,6)	70.000 (1778,0)	0.750 (19,0)	2.500 (63,5)	23	52	6.9 (195,6)	27.1 (12,3)
<b>12x4072-CP1</b>	72 (1820)	76.0 (1930,4)	82.000 (2082,8)	1.750 (44,4)	2.500 (63,5)	27	60	8.1 (229,6)	31.1 (14,1)

- └ x = 2; Carriage has 2 bearings; Carriage weight = 1.6 lbs. (0,73 kg)
- └ x = 4; Carriage has 4 bearings; Carriage weight = 1.8 lbs. (0,82 kg)

### Footnotes:

- (1) For travels greater than 72 inches (1820 mm) a cover plate (-CP1) cannot be used due to the sag of the cover plate.
- (2) Weight shown is with a 2 bearing carriage [1.6 lbs (0,73 kg)], a NEMA 23 motor mount [0.34 lbs (0,16 kg)], and a H100 style [0.08 lbs (0,04 kg)] coupling. When using a 4 bearing carriage add 0.2 lbs (0,09 kg) to each value.

## Dimensions

### - With Top Cover Plate Only -

Made in the U.S.A.

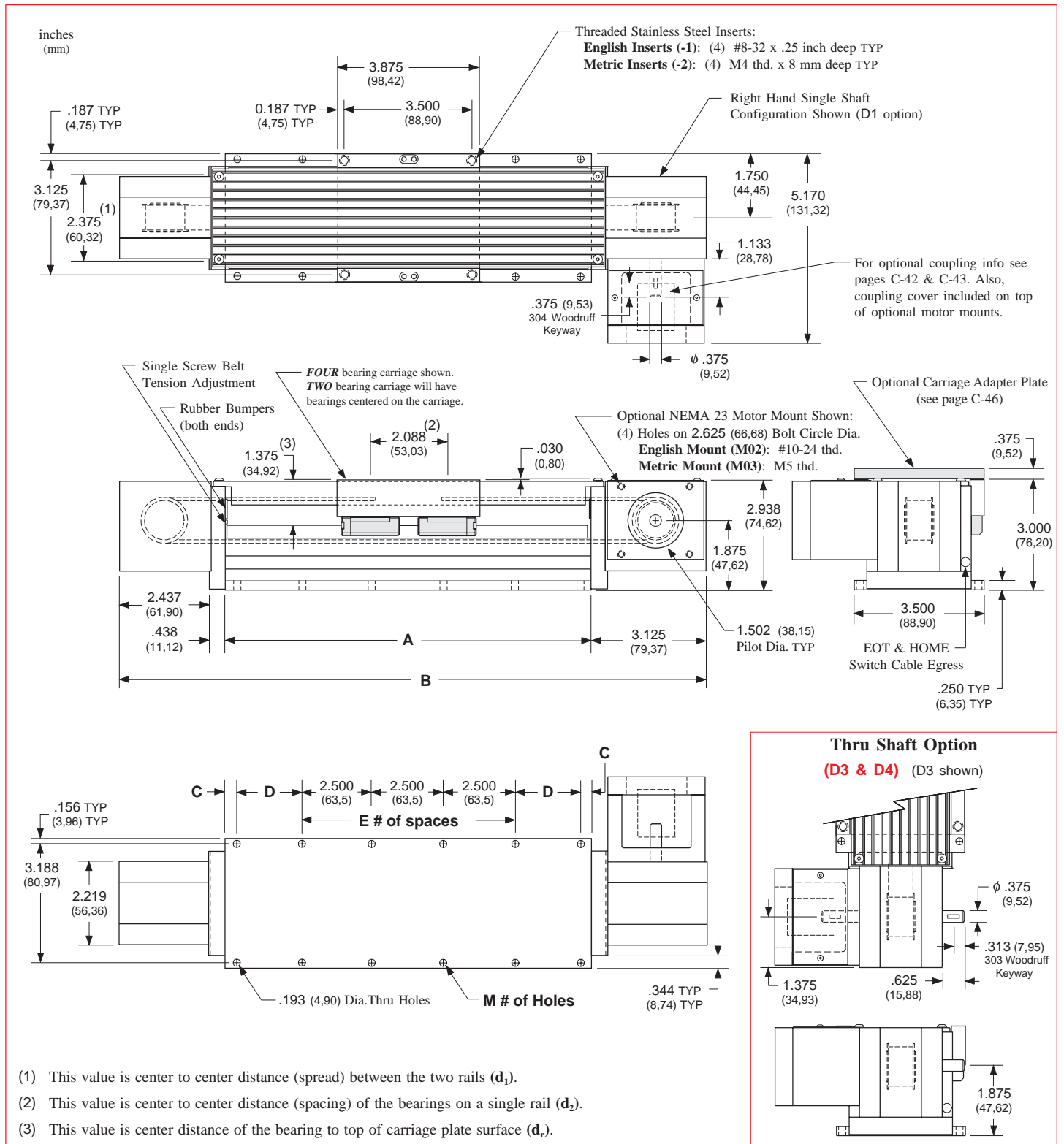

**Note:** Any 100, 110, 120 or 130 series table can be mounted on top of any second 100, 110, 120 series table by the user, in order to create X-Y multiple axis configurations. The 100-CP1, 100-CP2, or 120 series tables require one of the *Carriage Adapter Plate* options. The carriage's threaded stainless steel insert hole pattern exactly matches the base mounting hole pattern on each table, therefore no extra adapter bracket or machining is required. However a precision square tool, or micrometer depth gauge, is required in order to obtain an orthogonality between the two tables of < 30 arc-seconds. The table base, carriage top & carriage sides are all precision machined. *LINTECH's* 100 series, 4 bearing carriage, should be used for the bottom axis in a multiple axes application for better system rigidity, performance, and life.

Specifications subject to change without notice

Maximum Motor Input Torque, Maximum Belt Force, & Maximum Acceleration Rate

Maximum Motor Input Torque

The maximum safe speed/torque of a motor/drive system that can be used with the 120 series, is limited by the belt strength at a given speed. The maximum linear forces the belt can adequately handle are determined by the number of teeth on the pulley and the belt width. The chart below illustrates the relationship between motor input torque/belt force and carriage speed. Care should be taken when sizing and selecting a motor/drive system for use with a 120 series table. Exceeding the maximum input torque values at the listed speeds can cause belt "skipping" over pulley teeth. This will result in mis-positioning of the carriage.

Maximum Acceleration

The maximum acceleration rate using a 120 series table can be determined by the simple equation  $F = M \times A$ . Knowing the mass of the load, and the maximum safe operating force for the belt, the maximum possible acceleration rate can be determined. **Note:** The mechanical limitation for acceleration of the 120 series table is 2 g's.

Maximum Acceleration Example

- F** = **M** × **A**
- F** = maximum belt force at desired speed
- M** = user applied load
- A** = maximum acceleration rate (g's)
- Sin φ** = angle of table from horizontal (degrees)

<i>Horizontal Application</i>	<i>Vertical Application</i>
$A = \frac{F}{M}$	$A = \frac{F - M \sin \phi}{M}$

**Example:** A 40 lb load is mounted to a 120 series carriage in a horizontal application. Determine the maximum accel rate in g's & in/sec<sup>2</sup> that can be used to achieve a maximum speed of 75 IPS.

- Step 1:** From graph below, determine the maximum belt force at 75 IPS : (**F = 80 lbs**).
- Step 2:** Add up your total mass = load weight + carriage weight : (**M = 40 + 1.8 = 41.8 lbs**).
- Step 3:** Solve for A : (**A = 80/41.8 = 1.9 g's**).
- Note:** 1 g = 386 in/sec<sup>2</sup>
- Step 5:** 1.9 g's x 386 = 733 in/sec<sup>2</sup>.

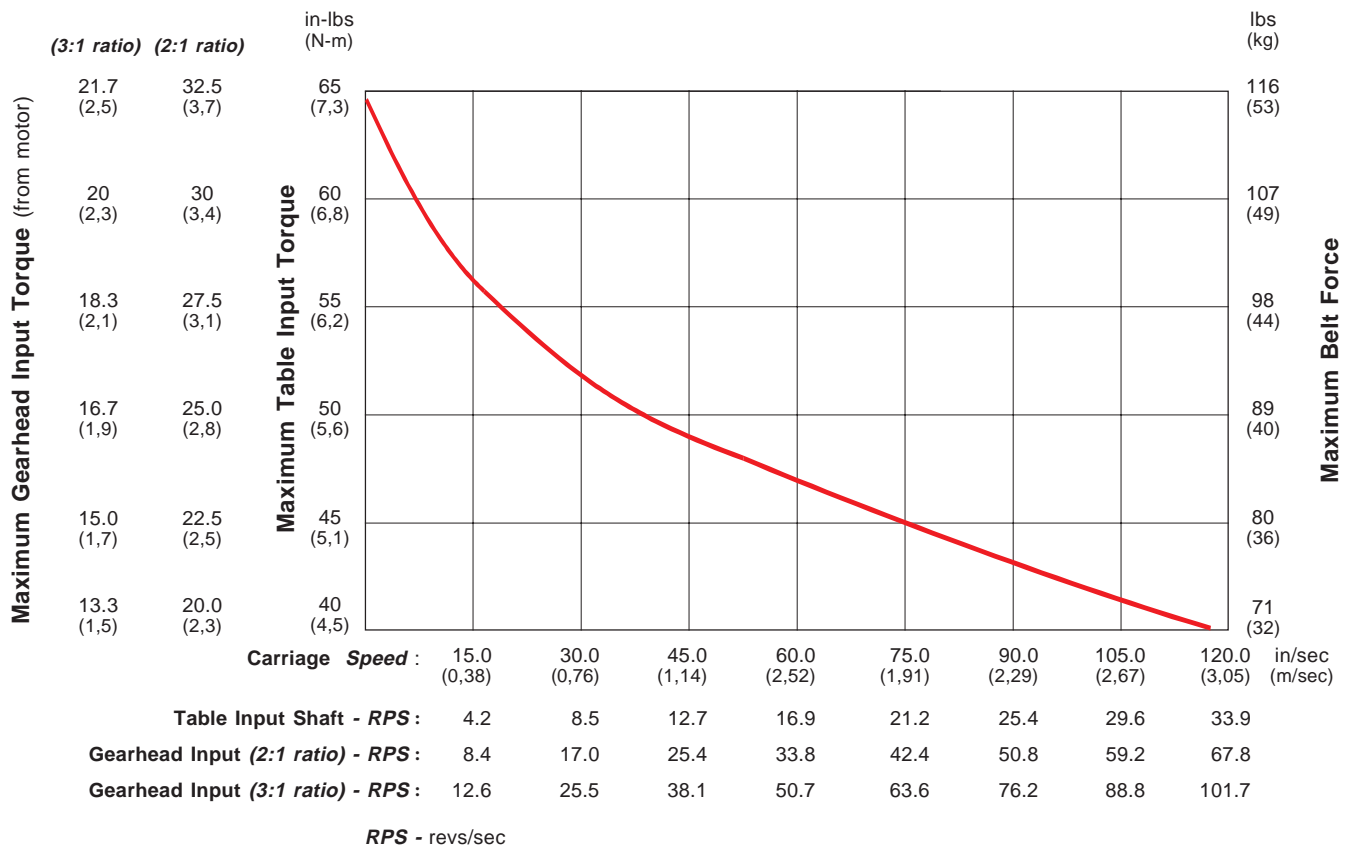

- 1) Table friction & breakaway forces have already been deducted from the above maximum belt force values.
- 2) Curve based upon maximum belt values. Select a motor coupling that can handle the required torque.

Master/Slave 120 Series Configuration

For some X-Y belt drive applications, the master/slave configuration shown to the right may be required. This system provides two bottom (X) axes spread apart a set distance, yet driven by one motor. The spreading of the two bottom axes minimizes the deflection on the Y axis, reduces the moment loading on the X axes carriages, increases the system rigidity, and prevents twisting of the Y axis as it accelerates to a set speed. *LINTECH* can provide the shaft supports, the cross shaft, the couplings, and the 120 series belt drive table without a motor mount bracket. The shaft supports are required as the couplings DO NOT provide adequate support of the shaft by themselves. Also, the shaft supports prevent the cross shaft from "whipping" at long lengths and high speeds.

The chart below lists the maximum carriage speed available with a given distance between shaft supports. A minimum of two shaft supports is always required. More than two can be used to increase the speed of a longer spread system. The equations below show the relationship between the # of shaft supports, the spread between the two bottom axes (B), and the distance between individual shaft supports (A).

A = distance between shaft supports  
 B = distance between 2 bottom axes

2 Shaft Supports:  $A = [B - 7.50 \text{ in (190,5 mm)}]$   
 3 Shaft Supports:  $A = [B - 8.53 \text{ in (216,7 mm)}] / 2$   
 4 Shaft Supports:  $A = [B - 9.56 \text{ in (242,8 mm)}] / 3$

Maximum Distance Between Shaft Supports A		Maximum Shaft Speed (RPM)	Equivalent Carriage Speed	
(inches)	(mm)		(in/sec)	(mm/sec)
<= 30	762	2000	118	3000
<= 36	914	1500	89	2250
<= 48	1219	840	50	1260
<= 54	1372	660	39	990
<= 60	1524	535	32	802
<= 66	1676	440	26	660
<= 72	1829	370	22	555
<= 84	2134	270	16	405
<= 96	2438	208	12	312
<= 108	2743	164	10	246
<= 120	3048	133	8	200

**Note:** The user is required to supply the mounting surface for the above configurations. *LINTECH* normally only supplies all the positioning hardware. A common base plate can be provided by *LINTECH* upon request.

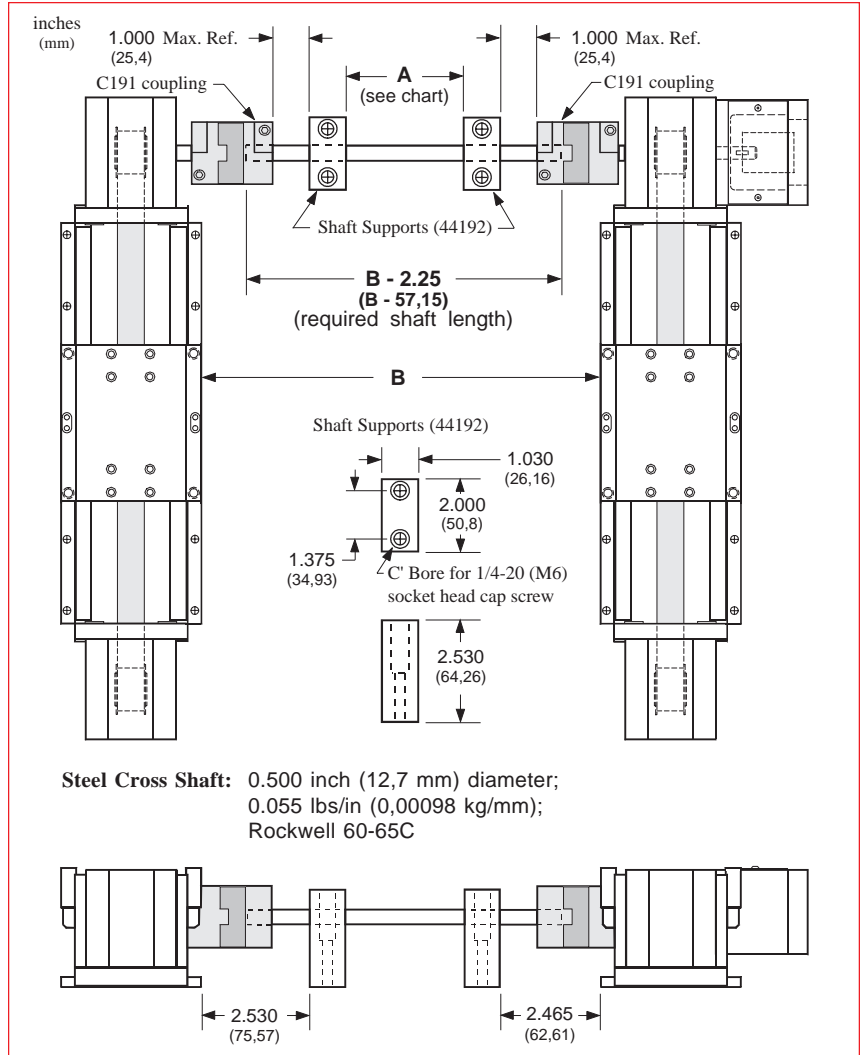

**Example #1:** Above configuration with Y axis and 2 extended carriage adapter plates.

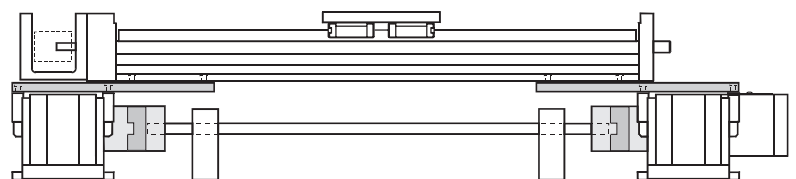

**Example #2:** Above configuration with Y axis, 2 extended carriage adapter plates, and 2 horizontal angle brackets.

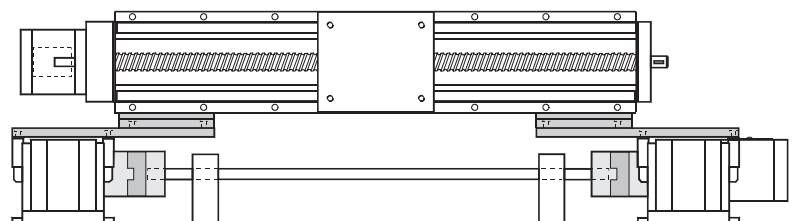

## Planetary Gearheads

For some 120 series belt drive positioning table applications, a NEMA gearhead may be required to increase motor speed and torque, while reducing the reflected load inertia that the motor sees. *LINTECH* offers two different styles of gearheads for its 120 series belt drive tables. The in-line version is ideal for those applications where the motor needs to be perpendicular to the table, while the right angle version will "wrap" the motor along side the table. Both gearheads come in either NEMA 23 or 34 frame sizes. When ordered with a 120 series table, the gearhead will be pre-mounted to the table by *LINTECH*. A motor shaft "sleeve", "clamp style mounting hub", and all mounting hardware, is provided with each gearhead. The self-aligning mounting hub maintains concentricity between the motor shaft and the gearhead. A motor adapter bracket, between the motor & gearhead, can also be provided for motors with non-NEMA mounting standards.

Model Number	Ratio	Peak Torque in-lbs (N-m)	Torque Output (5,000 hour life)			Torque Output (10,000 hour life)			Inertia in-lb-sec <sup>2</sup> x 10 <sup>-4</sup> (kg-cm <sup>2</sup> )	Torsional Stiffness in-lb/arc-min (N-m/arc-min)
			20 rps	50 rps	80 rps	20 rps	50 rps	80 rps		
<b>GIL23-03</b>	3:1	150 (17)	97 (11)	84 (10)	71 (8)	81 (9)	70 (8)	59 (7)	0.67 (0,076)	6.3 (0,7)
<b>GRA23-01</b>	1:1	195 (22)	57 (6)	54 (6)	50 (5)	53 (6)	50 (5)	46 (5)	7.01 (0,79)	5.6 (0,6)
<b>GRA23-02</b>	2:1	360 (41)	124 (14)	118 (13)	108 (12)	116 (13)	109 (12)	100 (11)	3.59 (0,41)	8.5 (1,0)
<b>GRA23-03</b>	3:1	270 (31)	79 (9)	75 (9)	69 (8)	74 (8)	70 (8)	64 (7)	3.09 (0,35)	9.6 (1,1)
<b>GIL34-03</b>	3:1	510 (58)	410 (46)	355 (40)	300 (34)	340 (38)	295 (33)	250 (28)	3.9 (0,44)	16.8 (1,9)
<b>GRA34-01</b>	1:1	493 (56)	160 (18)	153 (17)	140 (16)	150 (17)	142 (16)	130 (15)	27.5 (3,11)	12.6 (1,4)
<b>GRA34-02</b>	2:1	1113 (126)	365 (41)	348 (39)	319 (36)	341 (39)	321 (36)	295 (33)	14.1 (1,59)	19.1 (2,2)
<b>GRA34-03</b>	3:1	905 (102)	240 (27)	229 (26)	210 (24)	225 (25)	212 (24)	195 (22)	12.1 (1,37)	21.5 (2,4)

**Note:** The above gearheads have a backlash of 13 arc-minutes. Using any of the above gearheads in an application will add up to 0.0049 inch (0,012 mm) of backlash to the 120 series carriage. Therefore, the bidirectional repeatability of the carriage will change to +/- 0.0089 inches (0,226 mm). However, the unidirectional repeatability of the carriage will remain at +/- 0.001 inches (0,0254 mm). Also, gearheads with 4 arc-minutes backlash are available. This will add up to 0.0015 inch (0,038 mm) of backlash to the 120 series carriage.

Planetary Gearheads

In-line GIL23 & GIL34 series

AD - Adapter length will vary depending on motor used. Specify motor at time of order.

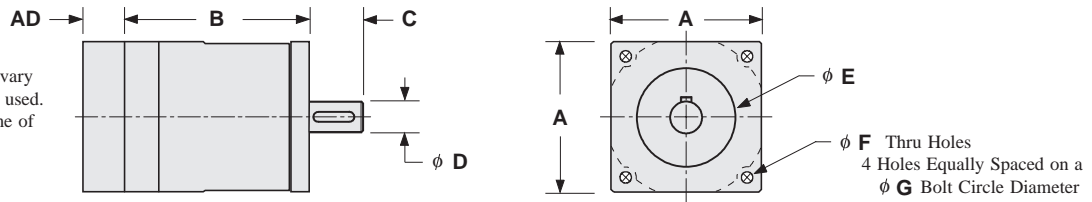

Model Number	A inches (mm)	B inches (mm)	C inches (mm)	D inches (mm)	E inches (mm)	F inches (mm)	G inches (mm)	Backlash arc-min	Weight lbs (kg)	Efficiency
<b>GIL23-03</b>	2.300 (58,4)	1.950 (49,5)	0.984 (25,0)	.375 (9,53)	1.500 (38,010)	.195 (4,95)	2.625 (66,68)	13 max	4.0 (1,8)	90 %
<b>GIL34-03</b>	3.622 (92,0)	2.470 (62,7)	1.575 (40,0)	.500 (12,7)	2.875 (73,03)	.218 (5,54)	3.875 (98,43)	13 max	8.0 (3,6)	90 %

Right Angle GRA23 & GRA34 series

Model Number	J inches (mm)	K inches (mm)	L inches (mm)
<b>GRA23-xx</b>	2.12 (54)	3.11 (79)	4.31 (110)
<b>GRA34-xx</b>	2.47 (63)	3.99 (101)	5.76 (146)

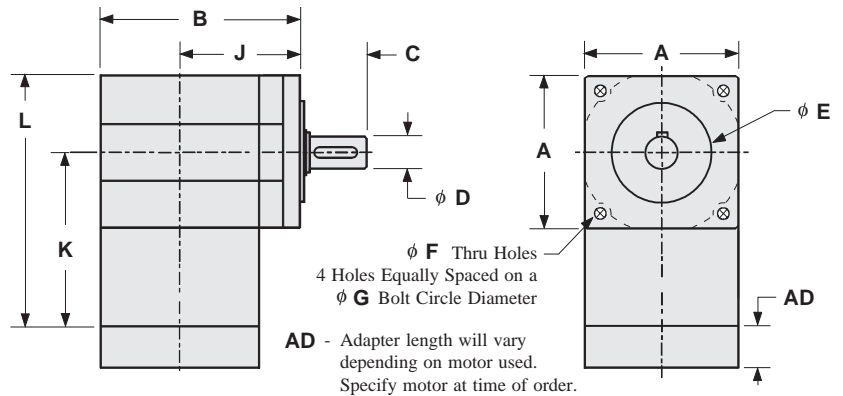

Model Number	A inches (mm)	B inches (mm)	C inches (mm)	D inches (mm)	E inches (mm)	F inches (mm)	G inches (mm)	Backlash arc-min	Weight lbs (kg)	Efficiency
<b>GRA23-xx</b>	2.270 (57,7)	3.320 (84,3)	1.000 (25,4)	.375 (9,53)	1.500 (38,10)	.195 (4,95)	2.625 (66,68)	13 max	3.0 (1,4)	90 %
<b>GRA34-xx</b>	3.250 (82,6)	4.240 (107,7)	1.250 (32,8)	.500 (12,70)	2.875 (73,03)	.218 (5,54)	3.875 (98,43)	13 max	6.0 (2,7)	90 %

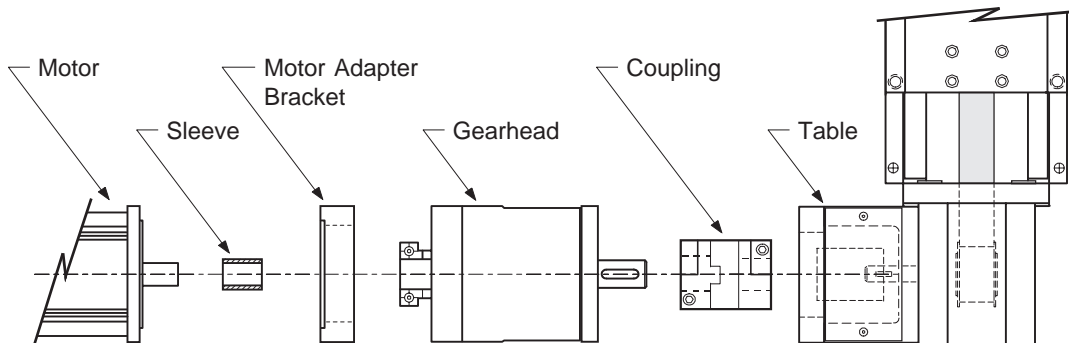

Specifications subject to change without notice

Table Deflection - Multiple Axis Configurations

The "moment of inertia" of an object is a gauge of the strength of that object to resist deflecting when used in an application or orientation where deflection might occur. The higher an I value relates to a lower amount of deflection. The following graphs can be used to estimate the deflection value for a given configuration. The information in the graphs was obtained with the bottom axis firmly mounted to a granite surface plate and also includes the deflection of the bottom axis carriage assembly & all mounting hardware. Individual applications will vary depending on the user mounting surface, user mounting hardware, and user mounting configuration. If the deflection values below are too high for your application, a steel sub plate, or aluminum cross member, can be added for additional "Y" axis support. Contact *LINTECH* for more details.

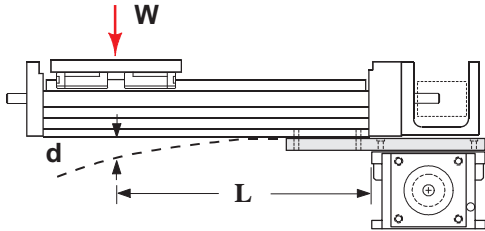

2 Bearing 100, 110 or 120 Series on Bottom Axis

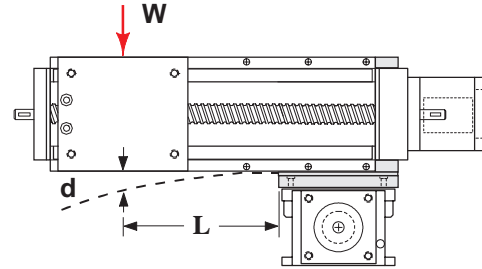
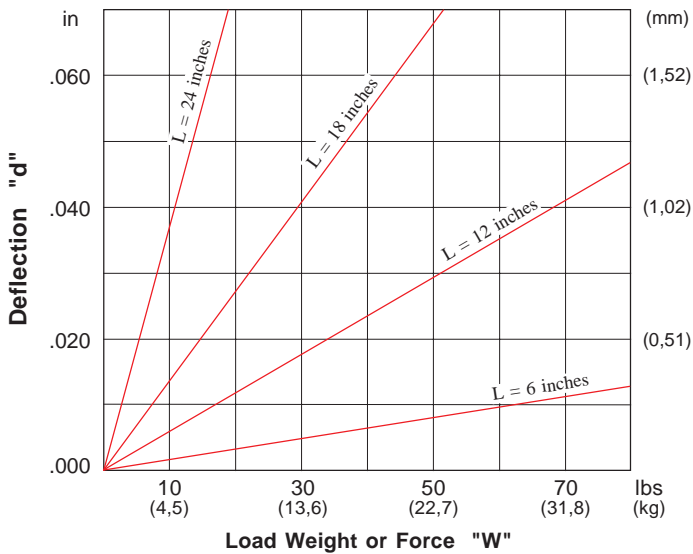

2 Bearing 100, 110 or 120 Series on Bottom Axis

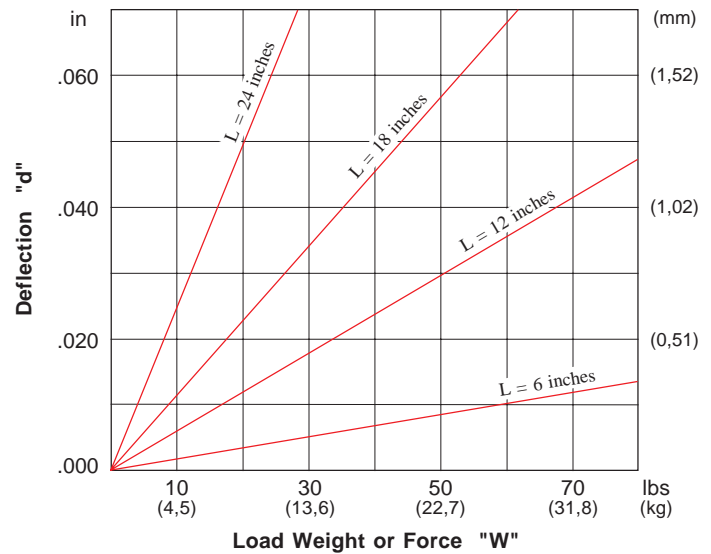

4 Bearing 100, 110 or 120 Series on Bottom Axis

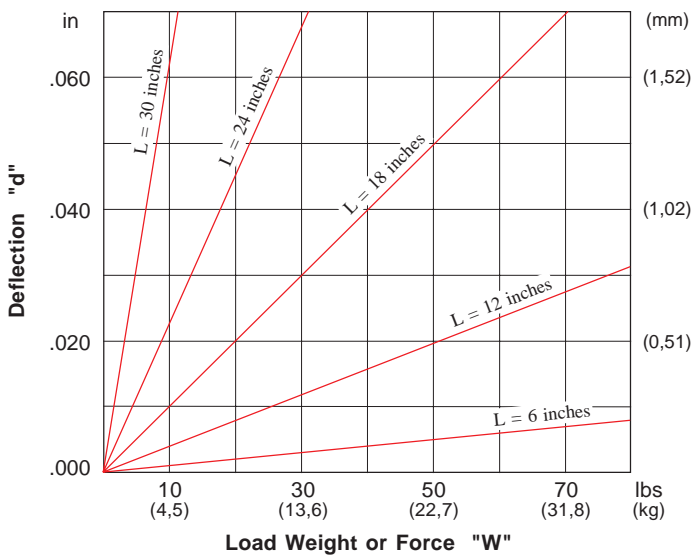

4 Bearing 100, 110 or 120 Series on Bottom Axis

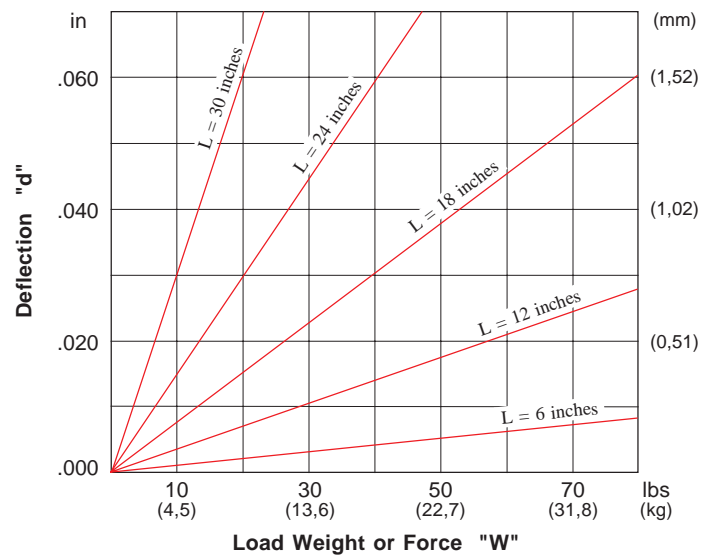

Specifications subject to change without notice

Table Deflection - Multiple Axis Configurations

$I = 0.30 \text{ in}^4 (1.25 \times 10^5 \text{ mm}^4)$

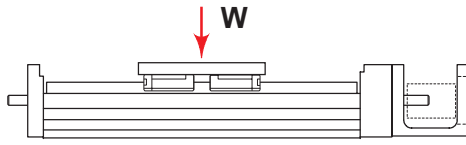

$I = 3.50 \text{ in}^4 (1.46 \times 10^6 \text{ mm}^4)$

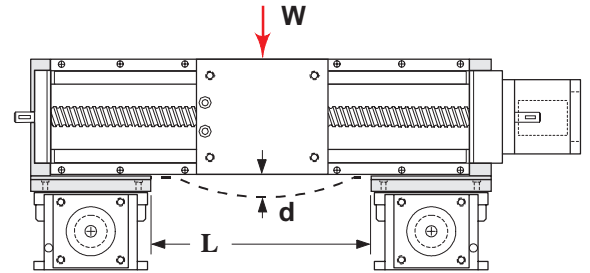
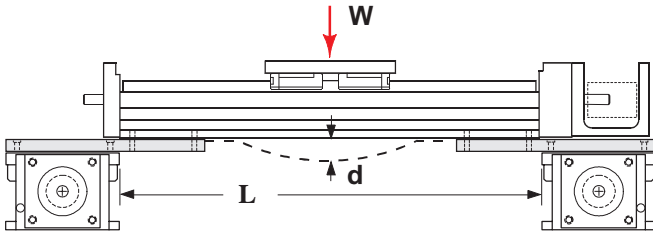
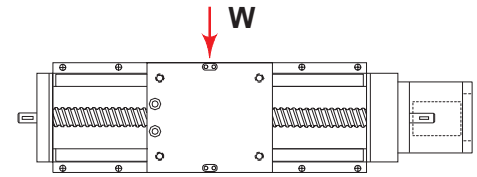

C

2 Bearing 100, 110 or 120 Series on Bottom Axis

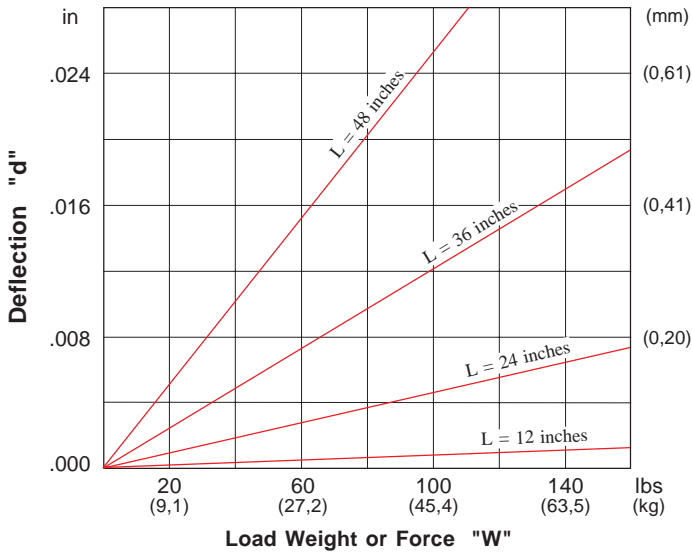

2 Bearing 100, 110 or 120 Series on Bottom Axis

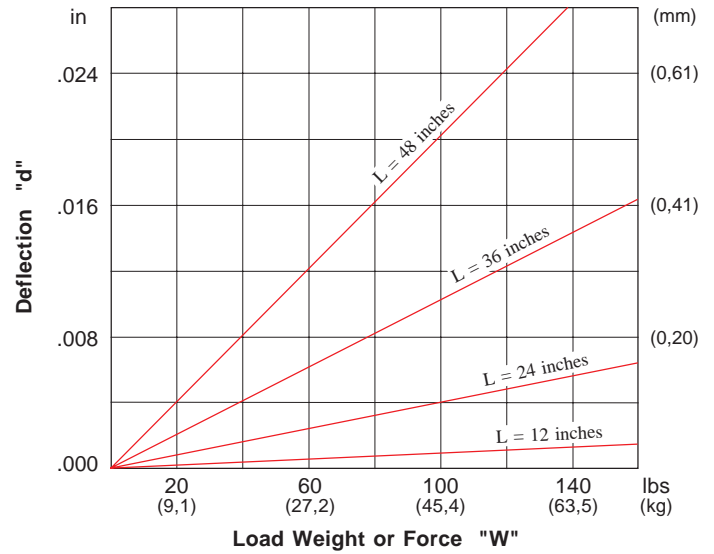

4 Bearing 100, 110 or 120 Series on Bottom Axis

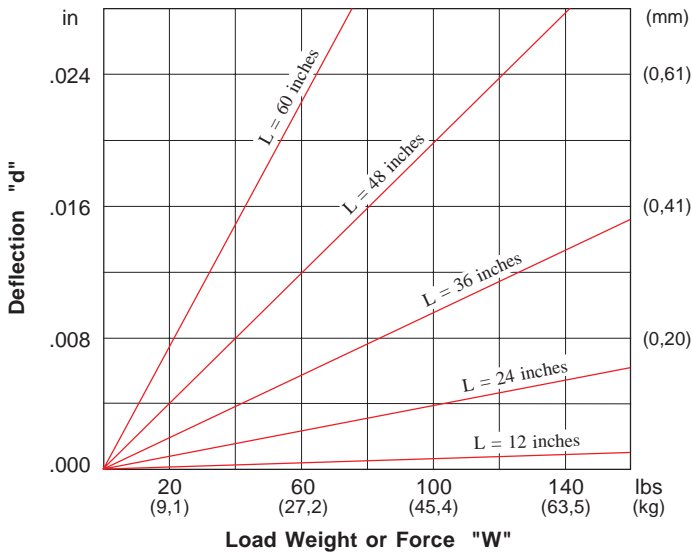

4 Bearing 100, 110 or 120 Series on Bottom Axis

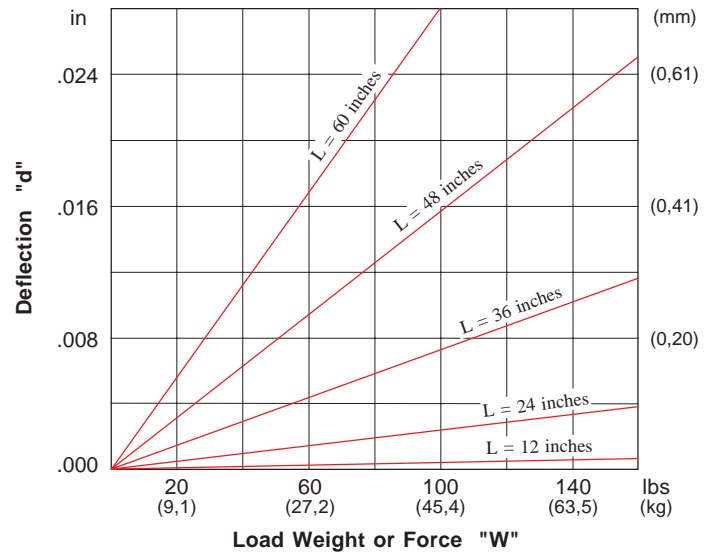

Specifications subject to change without notice

## Linear Bearing Load Capacities

The following equation, and graphs, can be used to help determine the linear bearing life, and load capacity, of a 100, 110 or 120 series positioning table.

$$L = \left[ \frac{R}{F \times S} \right]^3 \times B$$

- L** = calculated travel life (millions of inches or Km)
- R** = rated dynamic load capacity of carriage (or each bearing) at 2 million inches of travel or 50 Km
- F** = user applied load
- S** = safety factor (1 to 8)
- B** = either 2 (for millions of inches) or 50 (for Km)

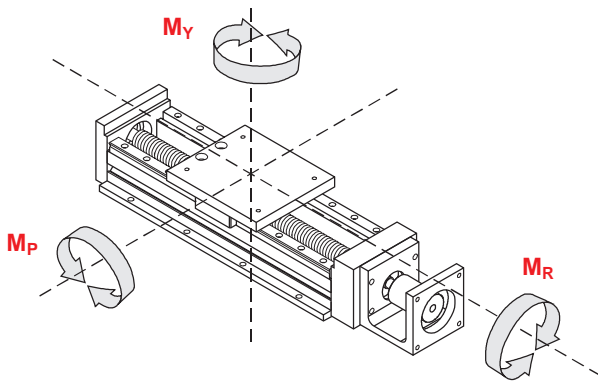

### Dynamic Horizontal Load Capacity

Load Centered on Carriage

travel life		2 Bearing		4 Bearing	
millions of inches	(Km)	lbs	(kg)	lbs	(kg)
2	( 50)	1,550	(703)	3,100	(1406)
50	(1270)	525	(238)	1,060	(480)
100	(2540)	415	(188)	840	(381)

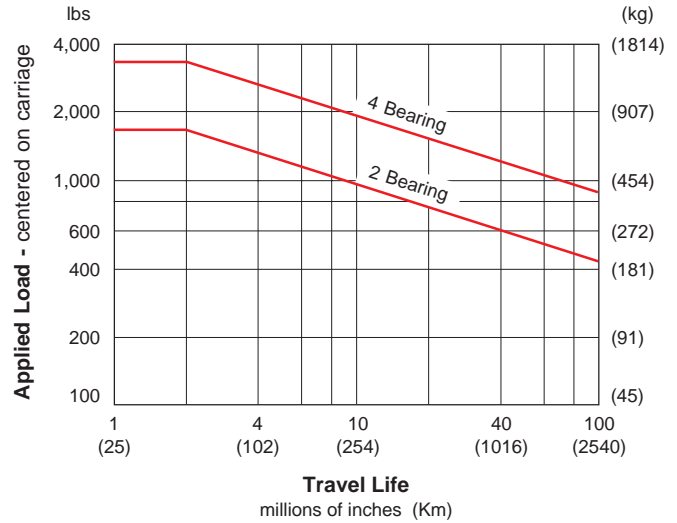

### Dynamic Moment Load (M<sub>R</sub>) Capacity

Load applied away from Carriage Center

travel life		2 Bearing		4 Bearing	
millions of inches	(Km)	ft-lbs	(N-m)	ft-lbs	(N-m)
2	( 50)	140	(190)	280	(379)
50	(1270)	47	(64)	95	(129)
100	(2540)	37	(50)	75	(101)

Ratings are based on d<sub>3</sub> = 12 inches (305 mm) & d<sub>4</sub> = 0

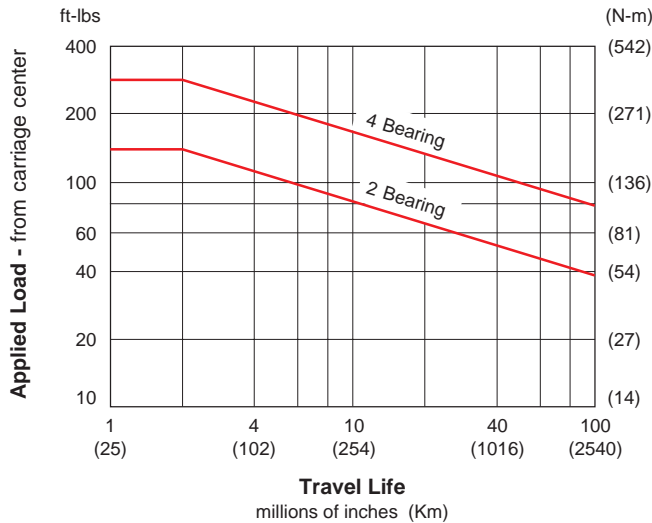

### Dynamic Moment Load (M<sub>P</sub> & M<sub>Y</sub>) Capacity

Load applied away from Carriage Center

travel life		2 Bearing		4 Bearing	
millions of inches	(Km)	ft-lbs	(N-m)	ft-lbs	(N-m)
2	( 50)	18	(24)	240	(325)
50	(1270)	6	(8)	82	(111)
100	(2540)	5	(7)	65	(88)

Ratings are based on d<sub>3</sub> = 0 & d<sub>4</sub> = 12 inches (305 mm)

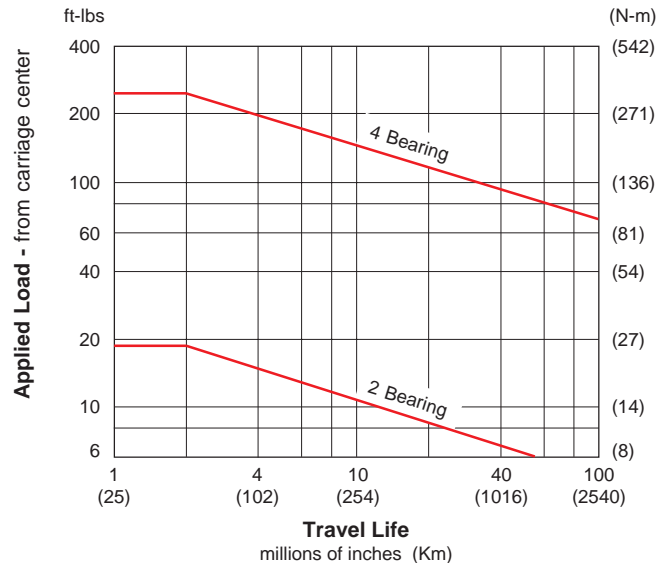

## End of Travel (EOT) Switches & Home Switch

*LINTECH* provides several options for EOT & home switches. One style uses mechanically actuated switches, while other styles use "non-contact" versions. When ordered with a *LINTECH* 100, 110 or 120 series table, each switch is mounted to the side of the table, while the actuating cams are mounted to the carriage assembly. The *T-slot* which runs along both sides of the 100, 110 and 120 series, allows the switches to be located anywhere along the table. The switches are pre-wired by *LINTECH* for easy interfacing to the users Motion Controller.

### End of Travel (EOT) Switches

End of travel (EOT) switches can be utilized by a motion controller to stop carriage motion, thereby preventing any damage to personnel, table carriage, or user mounted load if the extreme end of travel has been reached by the carriage. There are two EOT switches mounted to the side of the table, one on each end. The CCW switch is mounted at the motor mount end, while the CW switch is located at the opposite end of the table. *LINTECH* provides normally closed (NC) end of travel switches. This provides for a power-off fail safe system, where the position controller can detect broken wires. *It is highly recommended that any positioning table used with a position controller, should have end of travel switches installed for protection of personnel, table carriage, and user mounted load.*

### Home Switch

The home switch can be utilized by a motion controller as a known fixed mechanical location on the positioning table. The switch is located on the opposite side of the EOT switches, at the motor mount end, and is a normally open (NO) switch.

### Switch Locations

The following diagram shows the locations of the switches when ordered from *LINTECH*.

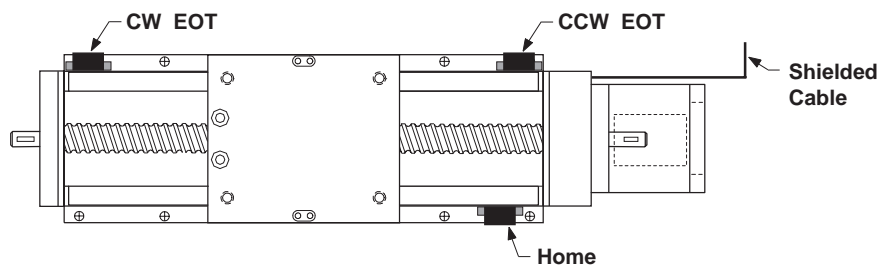

**Note:** For the 100 & 120 series, EOT switches are normally located 0.125 inches (3 mm) inward from the maximum travel hard stops. Thus, reducing overall system travel by 0.25 inches (6 mm) from listed table travel for each model #. For the 110 series there is NO reduction of listed travel length when using EOT switches.

**Note:** Each switch can be located anywhere along the T-slots, which run on both sides of the table.

Switch Type	Cost	Repeatability inches (microns)	Actuated	Power Supply Required	Activation Area inches (mm)	Comments
<b>mechanical</b>	least expensive	+/- 0.0002 (5)	mechanical	No	1.75 (44,45)	for most applications
<b>reed</b>	slightly more	+/- 0.0020 (50)	magnetic	No	0.30 (7,62)	for non-contact & low repeatable applications (ideal for 120 series)
<b>hall effect</b>	medium priced	+/- 0.0002 (5)	magnetic	Yes	0.32 (8,13)	for non-contact and wash down applications
<b>proximity</b>	most expensive	+/- 0.0002 (5)	non-magnetic	Yes	1.75 (44,45)	for non-contact, high speed, & wash down applications

**Note:** The repeatability of any switch is dependent upon several factors: carriage speed, accel rate, load weight, switch style, and the position controller. *LINTECH*'s ratings are based upon a carriage speed of 0.5 inches/sec (12.7 mm/sec) and a no load condition.

## End of Travel (EOT) Switches &amp; Home Switch

**Mechanical Switches**

Repeatability	: +/- 0.0002 inch (5 microns)
Electrical	: 5 amps @ 125 VAC 1 amp @ 85 VDC
Activation Style	: mechanical cam
Activation Area	: 1.75 inches (44,45 mm) of travel
Temperature Range	: - 25° C to + 85° C
Environment	: non wash down
Added Table Width	: 0.063 inch (1,6 mm) (EOT switches) 0.063 inch (1,6 mm) (with Home switch)
Individual Switch Wiring	: none

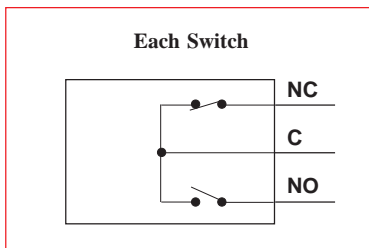

Standard *LINTECH* Wiring : from table end plate,  
(provided when switch option is 10 foot (3 m) shielded cable,  
ordered with any table) 6 conductor, 24 AWG,  
underminated leads

Wire Color	Description	
Black	CW EOT	NC
Blue	CW Common	C
Red	CCW EOT	NC
White	CCW Common	C
Brown	HOME	NO
Green	HOME Common	C
Silver	Shield	

**Note:** Hermetically sealed mechanical switches can be ordered as an option. This may be desired for "wash down" applications. Contact *LINTECH*.

Specifications subject to change without notice

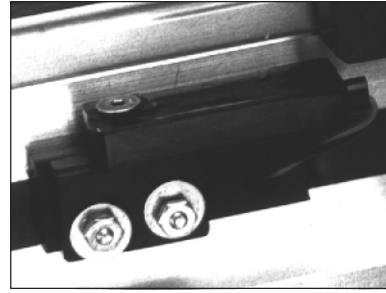
**Non-Contact Reed Switches**

Repeatability	: +/- 0.0020 inch (50 microns)
Electrical	: 1.0 amps @ 125 VAC 0.5 amps @ 100 VDC
Activation Style	: magnetic
Activation Area	: 0.30 inches (7,62 mm) of travel
Temperature Range	: - 10° C to + 60° C
Environment	: non wash down
Added Table Width	: none
Individual Switch Wiring	: 12 inch (305 mm) leads

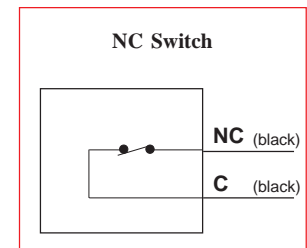
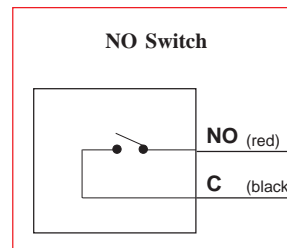

Standard *LINTECH* Wiring : from table end plate,  
(provided when switch option is 10 foot (3 m) shielded cable,  
ordered with any table) 6 conductor, 24 AWG,  
underminated leads

Wire Color	Description	
Black	CW EOT	NC
Blue	CW Common	C
Red	CCW EOT	NC
White	CCW Common	C
Brown	HOME	NO
Green	HOME Common	C
Silver	Shield	

CW - Clockwise  
CCW - Counter Clockwise  
EOT - End of Travel  
NC - Normally Closed  
NO - Normally Open

End of Travel (EOT) Switches & Home Switch

**Non-Contact Hall Effect Switches**

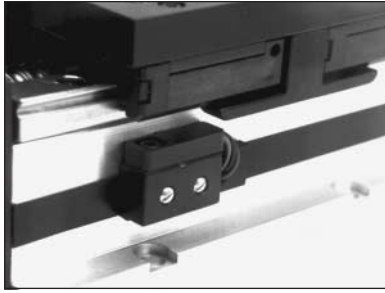

- Repeatability : +/- 0.0002 inch (5 microns)
- Electrical : 5 - 24 VDC  
15 mA - power input  
25 mA max - signal
- Actuation Style : magnetic
- Activation Area : 0.32 inches (8,13 mm) of travel
- Temperature Range : - 10° C to + 60° C
- Environment : wash down
- Added Table Width : none
- Individual Switch Wiring : 12 inch (305 mm) leads

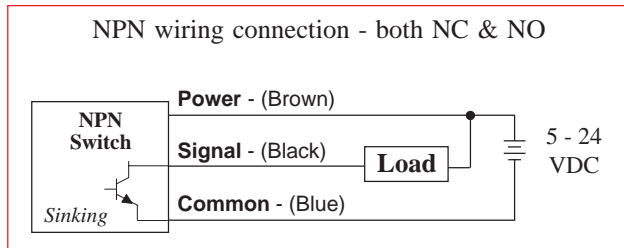

Standard *LINTECH* Wiring : from table end plate, (provided when switch option is ordered with any table) 10 foot (3 m) shielded cable; 9 conductor, 24 AWG, unterminated leads

Wire Color	Description		
Brown	CW Power	(brown)	switch <b>NC</b>
Black	CW EOT	(black)	
Blue	CW Common	(blue)	
Red	CCW Power	(brown)	switch <b>NC</b>
White	CCW EOT	(black)	
Green	CCW Common	(blue)	
Orange	Home Power	(brown)	switch <b>NO</b>
Yellow	Home	(black)	
Grey	Home Common	(blue)	
Silver	Shield		

**Non-Contact Proximity Switches**

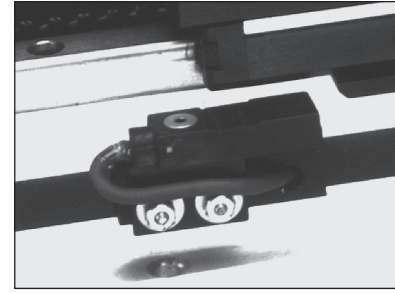

- Repeatability : +/- 0.0002 inch (5 microns)
- Electrical : 10 - 28 VDC  
15 mA - power input  
100 mA max - signal
- Actuation Style : non-magnetic cam
- Activation Area : 1.75 inches (44,45 mm) of travel
- Temperature Range : - 25° C to + 75° C
- Environment : IEC IP67 wash down
- Added Table Width : 0.20 inch (5,1 mm) (EOT switches)  
0.20 inch (5,1 mm) (Home switch)
- Individual Switch Wiring : 6.5 foot (2 m) cable for NPN  
3.3 foot (1 m) cable for PNP

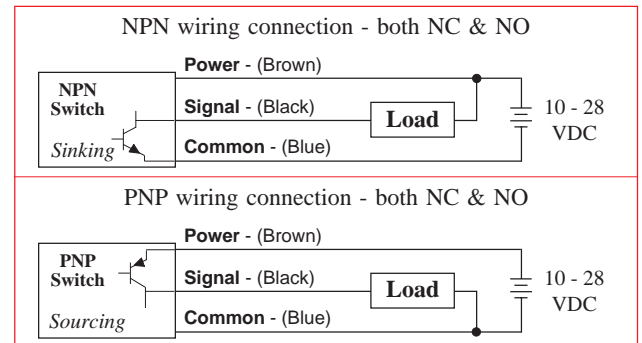

Standard *LINTECH* Wiring : from table end plate, (provided when switch option is ordered with any table) 10 foot (3 m) shielded cable; 9 conductor, 24 AWG, unterminated leads

Wire Color	Description		
Brown	CW Power	(brown)	switch <b>NC</b>
Black	CW EOT	(black)	
Blue	CW Common	(blue)	
Red	CCW Power	(brown)	switch <b>NC</b>
White	CCW EOT	(black)	
Green	CCW Common	(blue)	
Orange	Home Power	(brown)	switch <b>NO</b>
Yellow	Home	(black)	
Grey	Home Common	(blue)	
Silver	Shield		

Specifications subject to change without notice

## Motor Couplings

LINTECH provides three different types of couplings that can be used to mount a motor to a positioning table. These couplings compensate for misalignment between the motor shaft & screw (or belt) drive shaft extension. This provides for trouble-free operation as long as certain precautions are taken. The connected motor output torque should never exceed the coupling maximum torque capacity. Larger capacity couplings may be required for applications having high accelerations, large back driving loads, high torque output motors, or servo motors.

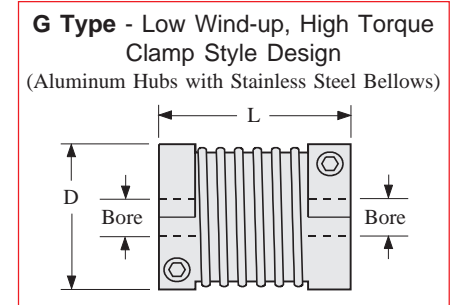
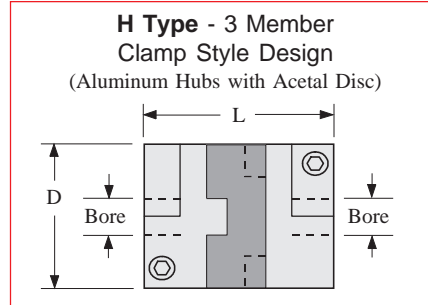
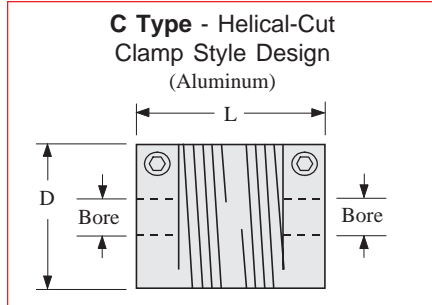

Model #	D inches (mm)	L inches (mm)	Bore Diameters				Weight ounces (grams)	Inertia oz-in <sup>2</sup> (g-cm <sup>2</sup> )	Wind-up arc-sec/oz-in (deg/N-m)	Max Torque oz-in (N-m)
			Table	Motor	Minimum (in) (mm)	Maximum (in) (mm)				
<b>C100-312-aaa</b>	1.00 (25,4)	1.50 (38,1)	<b>312</b>	<b>aaa</b>	.250 6	.375 10	1.5 (43)	.19 (35)	23.0 (0,9)	400 (2,8)
<b>C125-312-aaa</b> <sup>(1)</sup>	1.25 (31,8)	2.00 (50,8)	<b>312</b>	<b>aaa</b>	.250 6	.500 14	3.5 (99)	.68 (124)	15.0 (0,59)	700 (4,9)
<b>H100-312-aaa</b>	1.00 (25,4)	1.28 (32,5)	<b>312</b>	<b>aaa</b>	.250 6	.375 10	1.2 (34)	.15 (27)	7.2 (0,28)	450 (2,8)
<b>H100-375-aaa</b>	1.00 (25,4)	1.28 (32,5)	<b>375</b>	<b>aaa</b>	.250 6	.375 10	1.2 (34)	.15 (27)	7.2 (0,28)	450 (2,8)
<b>H131-312-aaa</b> <sup>(1)</sup>	1.31 (33,3)	1.89 (48,0)	<b>312</b>	<b>aaa</b>	.250 6	.625 16	2.9 (82)	.62 (114)	2.5 (0,098)	1,000 (7,1)
<b>H131-375-aaa</b>	1.31 (33,3)	1.89 (48,0)	<b>375</b>	<b>aaa</b>	.250 6	.625 16	2.9 (82)	.62 (114)	2.5 (0,098)	1,000 (7,1)
<b>H163-375-aaa</b> <sup>(2)</sup>	1.63 (41,4)	2.00 (50,8)	<b>375</b>	<b>aaa</b>	.375 10	.750 20	5.4 (153)	1.79 (328)	1.2 (0,047)	2,000 (14,1)
<b>G100-312-aaa</b>	0.99 (25,2)	1.26 (32,0)	<b>312</b>	<b>aaa</b>	.250 6	.500 12	1.3 (36)	.16 (29)	1.0 (0,39)	500 (3,5)
<b>G100-375-aaa</b>	0.99 (25,2)	1.26 (32,0)	<b>375</b>	<b>aaa</b>	.250 6	.500 12	1.3 (36)	.16 (29)	1.0 (0,39)	500 (3,5)
<b>G126-312-aaa</b>	1.26 (32,1)	1.62 (41,0)	<b>312</b>	<b>aaa</b>	.250 6	.625 16	2.7 (74)	.54 (99)	0.3 (0,012)	1,100 (7,7)
<b>G126-375-aaa</b>	1.26 (32,1)	1.62 (41,0)	<b>375</b>	<b>aaa</b>	.250 6	.625 16	2.7 (74)	.54 (99)	0.3 (0,012)	1,100 (7,7)
<b>G158-375-aaa</b> <sup>(2)</sup>	1.58 (40,2)	1.85 (47,0)	<b>375</b>	<b>aaa</b>	.375 10	.750 20	4.3 (120)	1.34 (245)	0.2 (0,008)	2,400 (17,0)
Possible values for <b>aaa</b>	250 = .250 inch 375 = .375 inch 500 = .500 inch 625 = .625 inch		750 = .750 inch		005 = 5 mm 006 = 6 mm 008 = 8 mm 010 = 10 mm		012 = 12 mm 014 = 14 mm 016 = 16 mm 018 = 18 mm		019 = 19 mm 020 = 20 mm	

**Footnotes:**

- (1) This coupling option can not be used with the optional NEMA 23 motor mount for the 100 & 110 series because its length is too long. However, this coupling option can be used with the optional NEMA 34 motor mount. Custom motor mounts can be provided upon request. See page C-43 for more details.
- (2) This coupling option can not be used with the optional NEMA 23 motor mount for the 120 series because its diameter is too big. However, this coupling option can be used with the optional NEMA 34 motor mount. Custom motor mounts can be provided upon request. See page C-43 for more details.

Specifications subject to change without notice

## Motor Couplings

Coupling	Cost	Torque Capacity	Wind-up	Suggested Motor	Comments
<b>C Type</b>	least expensive	light	the most	stepper	ideal for most step motor applications
<b>H Type</b>	medium priced	medium	medium	stepper or servo	use for high accels & for starting & stopping large inertia loads
<b>G Type</b>	most expensive	high	the least	servo	use for very high torque requirements & very high servo accelerations

Specification	100 & 110 Series	100 & 110 Series	120 Series	120 Series
	NEMA 23 bracket inches (mm)	NEMA 34 bracket inches (mm)	NEMA 23 bracket inches (mm)	NEMA 34 bracket inches (mm)
<b>Shaft extension diameter at motor mount end</b>	0.312 (7,92)	0.312 (7,92)	0.375 (9,53)	0.375 (9,53)
<b>Maximum coupling diameter</b>	1.500 (38,10)	1.500 (38,10)	1.500 (38,10)	2.000 (50,80)
<b>Maximum coupling length</b>	1.750 (44,45)	2.250 (57,15)	1.900 (48,26)	2.375 (60,32)

**Note:** Custom brackets available upon request.

## Coupling Part Numbers

<b>C020</b> C100-312-250	<b>C125</b> H100-312-250	<b>C155</b> H131-375-250	<b>C400</b> G100-312-250	<b>C435</b> G126-375-250
<b>C021</b> C100-312-375	<b>C126</b> H100-312-375	<b>C156</b> H131-375-375	<b>C401</b> G100-312-375	<b>C436</b> G126-375-375
<b>C022</b> C100-312-006	<b>C127</b> H100-312-006	<b>C157</b> H131-375-500	<b>C402</b> G100-312-500	<b>C437</b> G126-375-500
<b>C023</b> C100-312-008	<b>C128</b> H100-312-008	<b>C158</b> H131-375-625	<b>C403</b> G100-312-006	<b>C438</b> G126-375-625
<b>C024</b> C100-312-010	<b>C129</b> H100-312-010	<b>C159</b> H131-375-006	<b>C404</b> G100-312-008	<b>C439</b> G126-375-006
		<b>C160</b> H131-375-008	<b>C405</b> G100-312-010	<b>C440</b> G126-375-008
<b>C040</b> C125-312-250	<b>C130</b> H100-375-250	<b>C161</b> H131-375-010	<b>C406</b> G100-312-012	<b>C441</b> G126-375-010
<b>C041</b> C125-312-375	<b>C131</b> H100-375-375	<b>C162</b> H131-375-012		<b>C442</b> G126-375-012
<b>C042</b> C125-312-500	<b>C132</b> H100-375-006	<b>C163</b> H131-375-014	<b>C407</b> G100-375-250	<b>C443</b> G126-375-014
<b>C043</b> C125-312-006	<b>C133</b> H100-375-008	<b>C164</b> H131-375-016	<b>C408</b> G100-375-375	<b>C444</b> G126-375-016
<b>C044</b> C125-312-008	<b>C134</b> H100-375-010		<b>C409</b> G100-375-500	
<b>C045</b> C125-312-010		<b>C190</b> H163-375-375	<b>C410</b> G100-375-006	<b>C470</b> G158-375-375
<b>C046</b> C125-312-012	<b>C145</b> H131-312-250	<b>C191</b> H163-375-500	<b>C411</b> G100-375-008	<b>C471</b> G158-375-500
<b>C047</b> C125-312-014	<b>C146</b> H131-312-375	<b>C192</b> H163-375-625	<b>C412</b> G100-375-010	<b>C472</b> G158-375-625
	<b>C147</b> H131-312-500	<b>C193</b> H163-375-750	<b>C413</b> G100-375-012	<b>C473</b> G158-375-750
	<b>C148</b> H131-312-625	<b>C194</b> H163-375-010		<b>C474</b> G158-375-010
	<b>C149</b> H131-312-006	<b>C195</b> H163-375-012	<b>C425</b> G126-312-250	<b>C475</b> G158-375-012
	<b>C150</b> H131-312-008	<b>C196</b> H163-375-014	<b>C426</b> G126-312-375	<b>C476</b> G158-375-014
	<b>C151</b> H131-312-010	<b>C197</b> H163-375-016	<b>C427</b> G126-312-500	<b>C477</b> G158-375-016
	<b>C152</b> H131-312-012	<b>C198</b> H163-375-018	<b>C428</b> G126-312-625	<b>C478</b> G158-375-018
	<b>C153</b> H131-312-014	<b>C199</b> H163-375-019	<b>C429</b> G126-312-006	<b>C479</b> G158-375-019
	<b>C154</b> H131-312-016	<b>C200</b> H163-375-020	<b>C430</b> G126-312-008	<b>C480</b> G158-375-020
			<b>C431</b> G126-312-010	
			<b>C432</b> G126-312-012	
			<b>C433</b> G126-312-014	
			<b>C434</b> G126-312-016	

## Horizontal & Vertical Angle Brackets

*LINTECH* has provided a simple solution for those applications requiring multiple axis positioning. Two different angle brackets (a horizontal mount and a vertical mount) provide for X-Y, X-Z, and X-Y-Z configurations. These angle brackets are used to mount single axis tables together in order to form multiple axis configurations, or to orient the single axis table in a different plane of motion.

These precision machined aluminum angle brackets ensure that the orthogonality of the two tables is maintained to  $< 30$  arc-seconds. To achieve this orthogonality, one side of the angle bracket must be mounted to the table carriage with a precision square tool or micrometer depth gauge,

while the second axis is mounted securely against the reference edge of the angle bracket. The angle bracket hole pattern is pre-engineered for easy mounting of either the table carriage or table base.

When ordered, the angle bracket is shipped separately from the tables. The user is required to assemble the angle bracket to the tables. However, if requested, *LINTECH* can pre-assemble the multiple axis system before shipping. Anytime an angle bracket is used for multiple axis configurations, moment loads will result on one or more axes. Be sure to review moment loads, and the positioning table life, for your application.

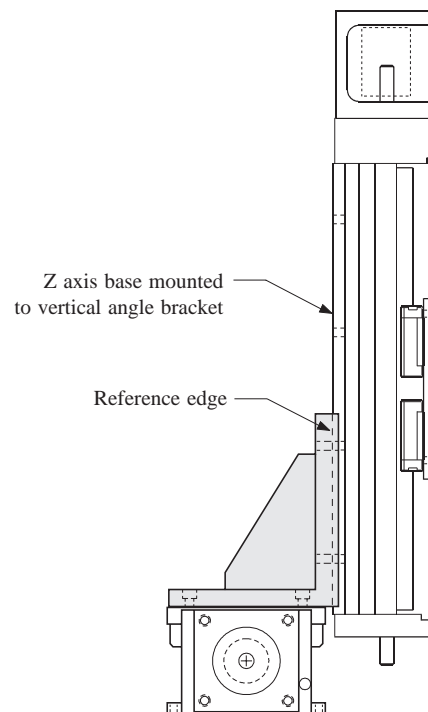
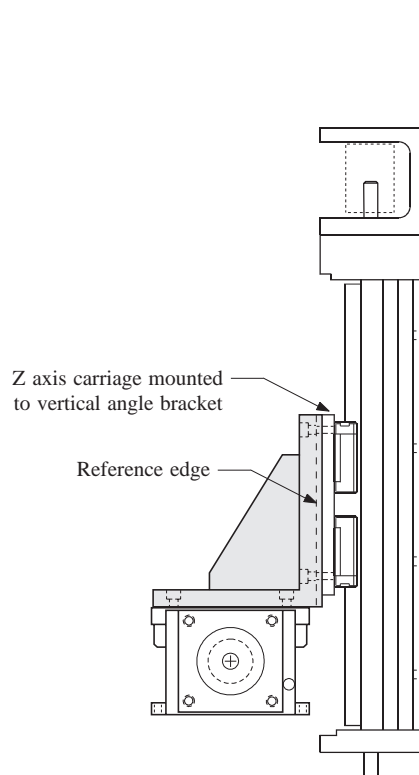
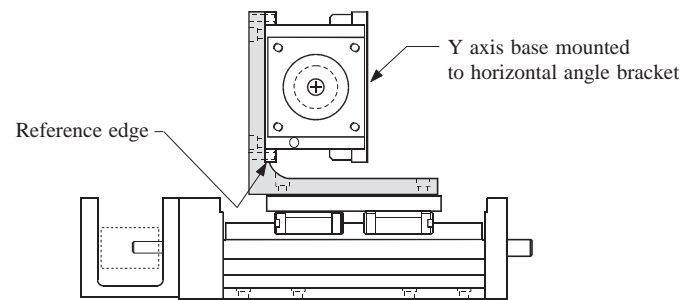
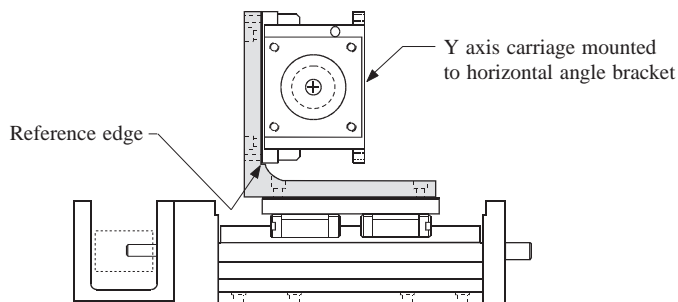

Horizontal Angle Bracket

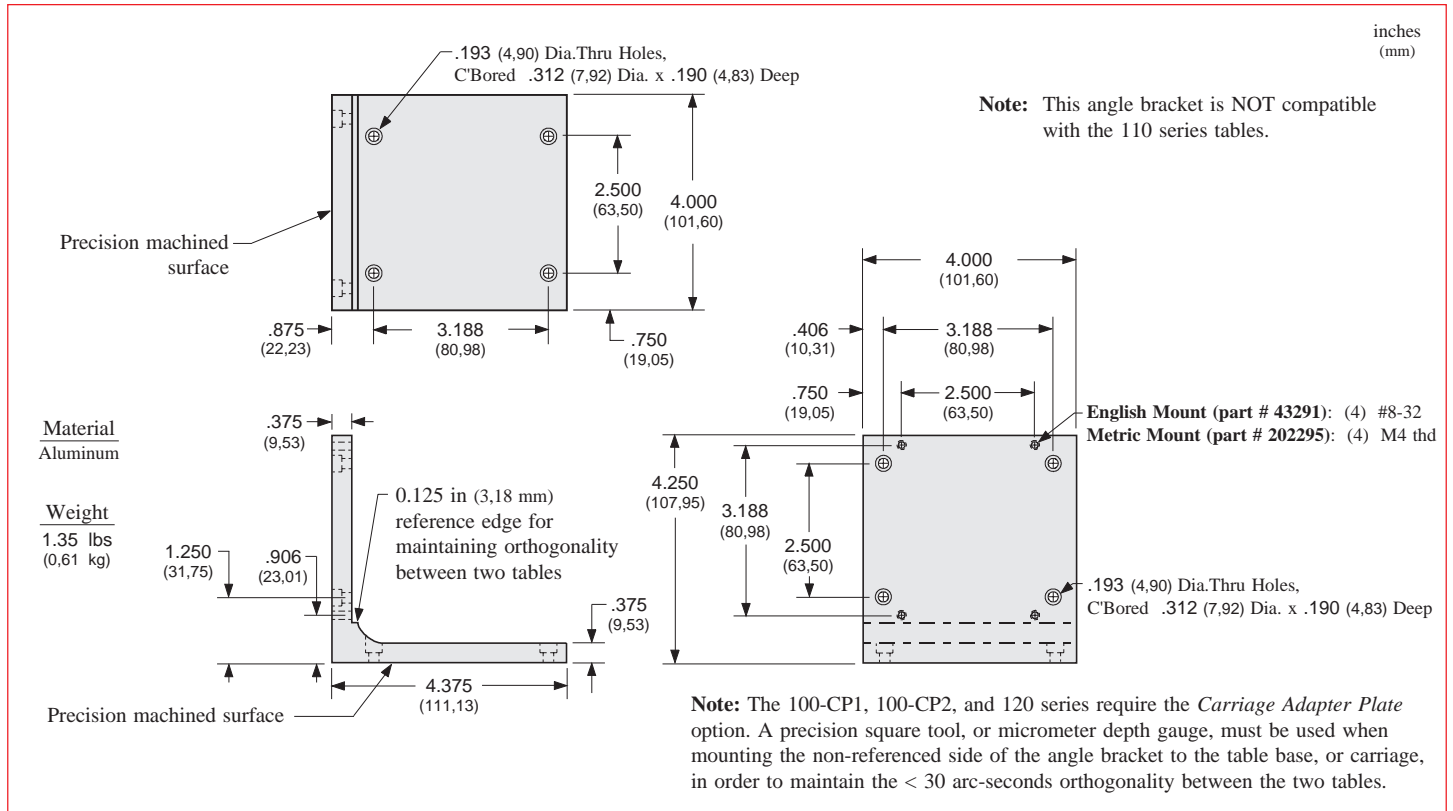

C

Vertical Angle Bracket

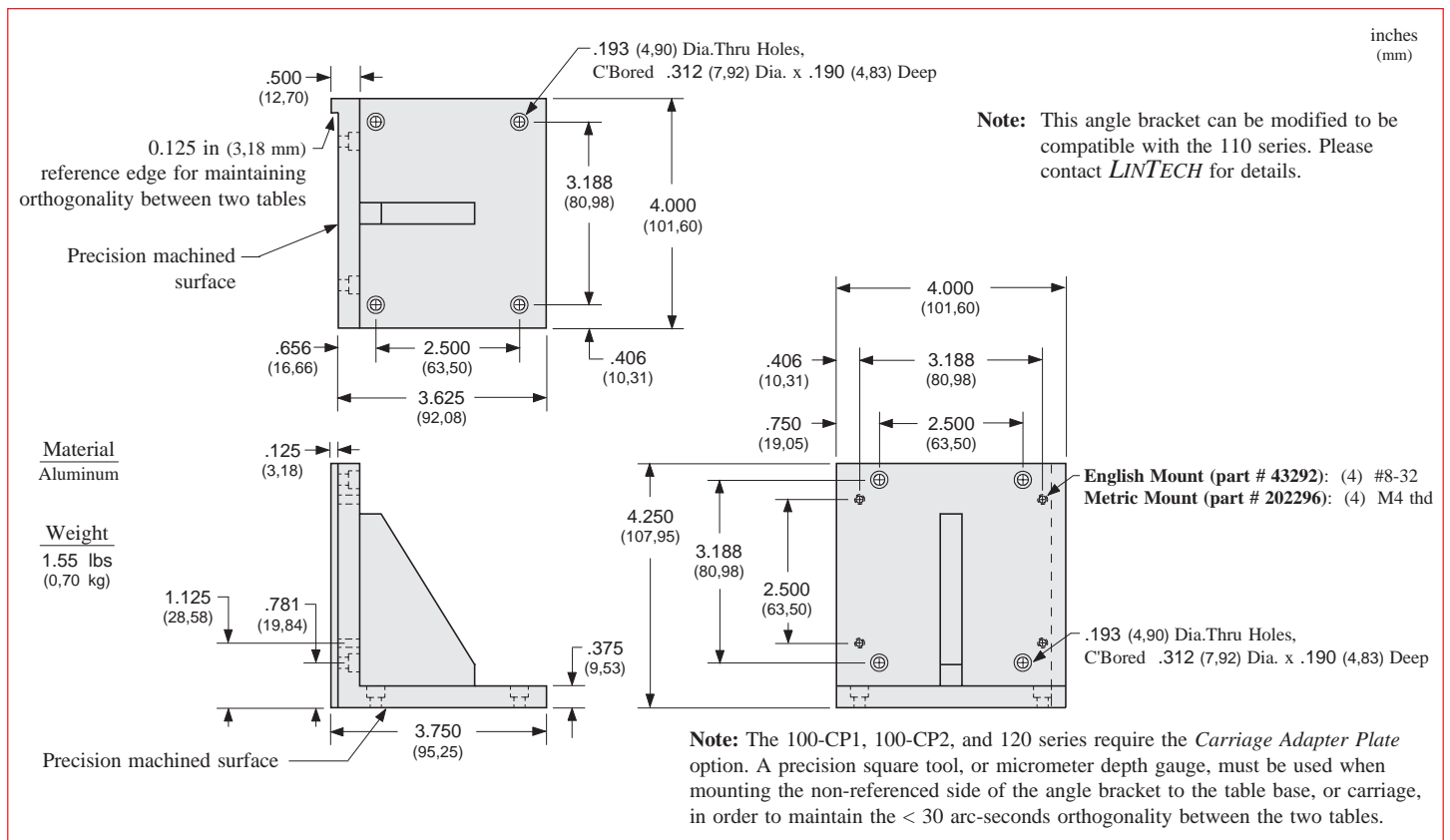

## Carriage Adapter Plates

Optional carriage adapter plates assist in the creation of simple X-Y, X-Z, and X-Y-Z multiple axis systems. The regular carriage adapter plate can be used by either the 100-CP1, 100-CP2, or 120 series tables, while the extended adapter plate can be used with the 100, 110, or 120 series tables. The extended carriage adapter plate can be used in applications to increase the Y axis travel without having to use a longer travel table. A precision square tool, or micrometer depth gauge, is required in order to obtain an orthogonality between the two tables of < 30 arc-seconds.

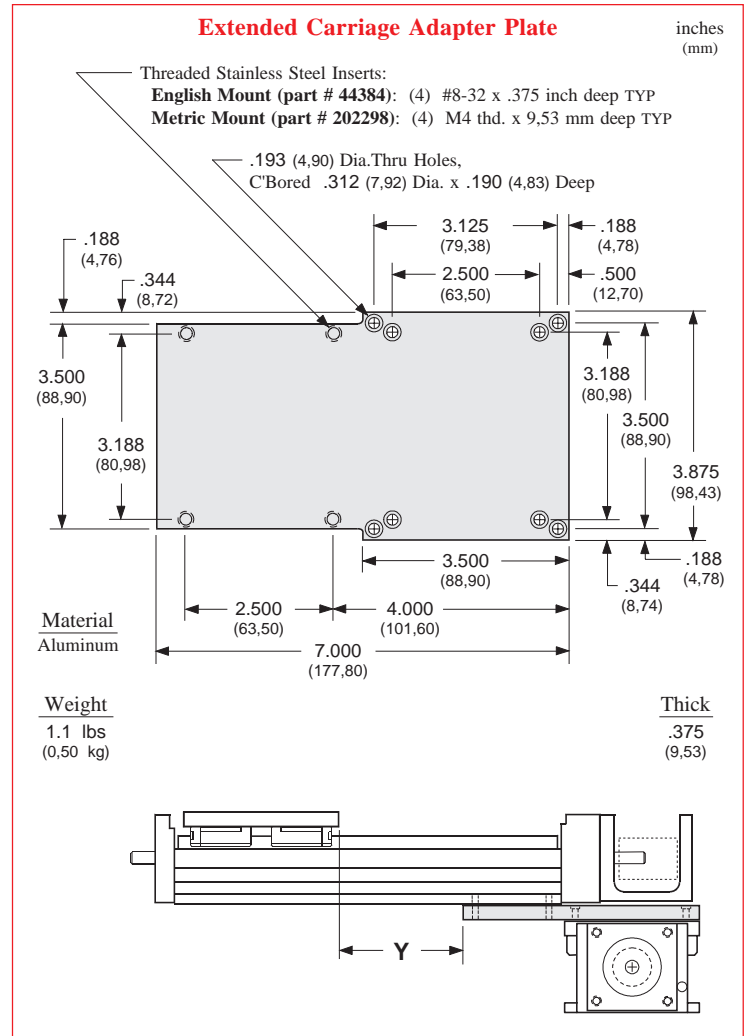
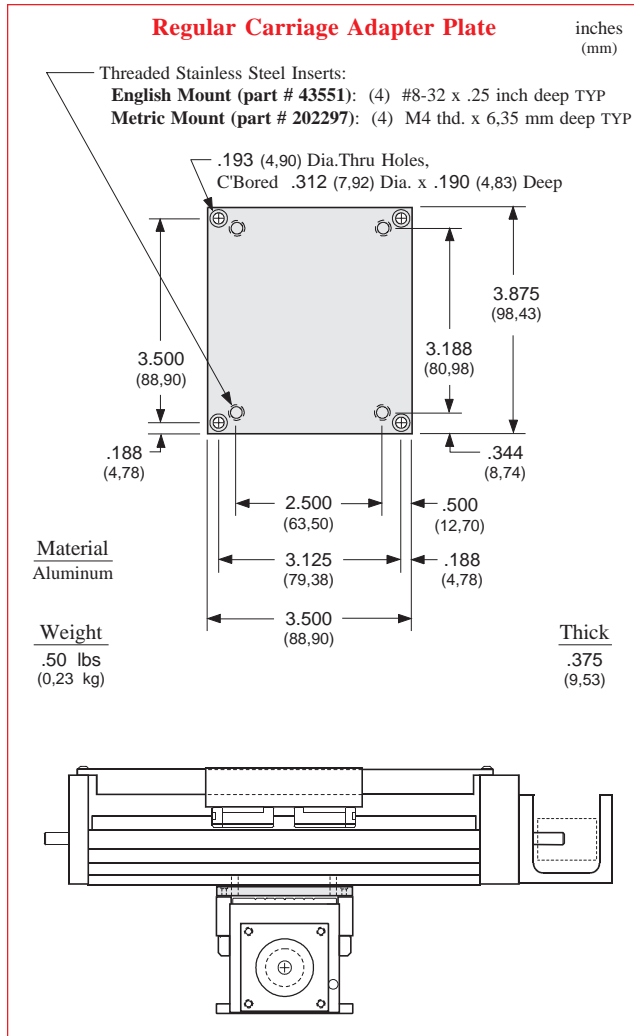
**Notes:**

(1) Above **Y** travel distance (need to refer to Base Mounting Dimensions on pages C-6, C-8, C-10, C-14 & C-28):

For **D** dimension = 2.50 inches (63,5 mm):  $Y = [\text{table travel length}] - [\text{C dimension}] + [0.50 \text{ inches (12,7 mm)}]$

For **D** dimension < 2.50 inches (63,5 mm):  $Y = [\text{table travel length}] - [\text{C dimension}] - [\text{D dimension}] + [0.50 \text{ inches (12,7 mm)}]$

\* Subtract an additional 0.875 inches (22,22 mm) from the above values if a 110 series table is used as the bottom axis.

\* If a 110 series table is used as the top axis, the **Y** travel distance is the same as the 110 series table travel due to the waycovers.

\* The extended carriage adapter plate works with all top axis tables that use the optional NEMA 23 motor mount. Care should be taken if the optional NEMA 34 motor mount, or any other motor mount is used on the top axis table. The motor mount could extend below the table base, thus interfering with the extended carriage adapter plate.

Multiple Axis Configurations

With *LINTECH*'s uniquely designed angle brackets & carriage adapter plates, along with the symmetrical base mounting hole pattern & carriage insert pattern of the 100 and 120 series positioning tables, numerous X-Y, X-Z, and X-Y-Z configurations are possible. The 100-CP1, 100-CP2, and 120 series tables require the use of a "Carriage Adapter Plate". The increased width of the 110 (waycover) series prohibits the use of the horizontal and vertical angle brackets with these positioning tables.

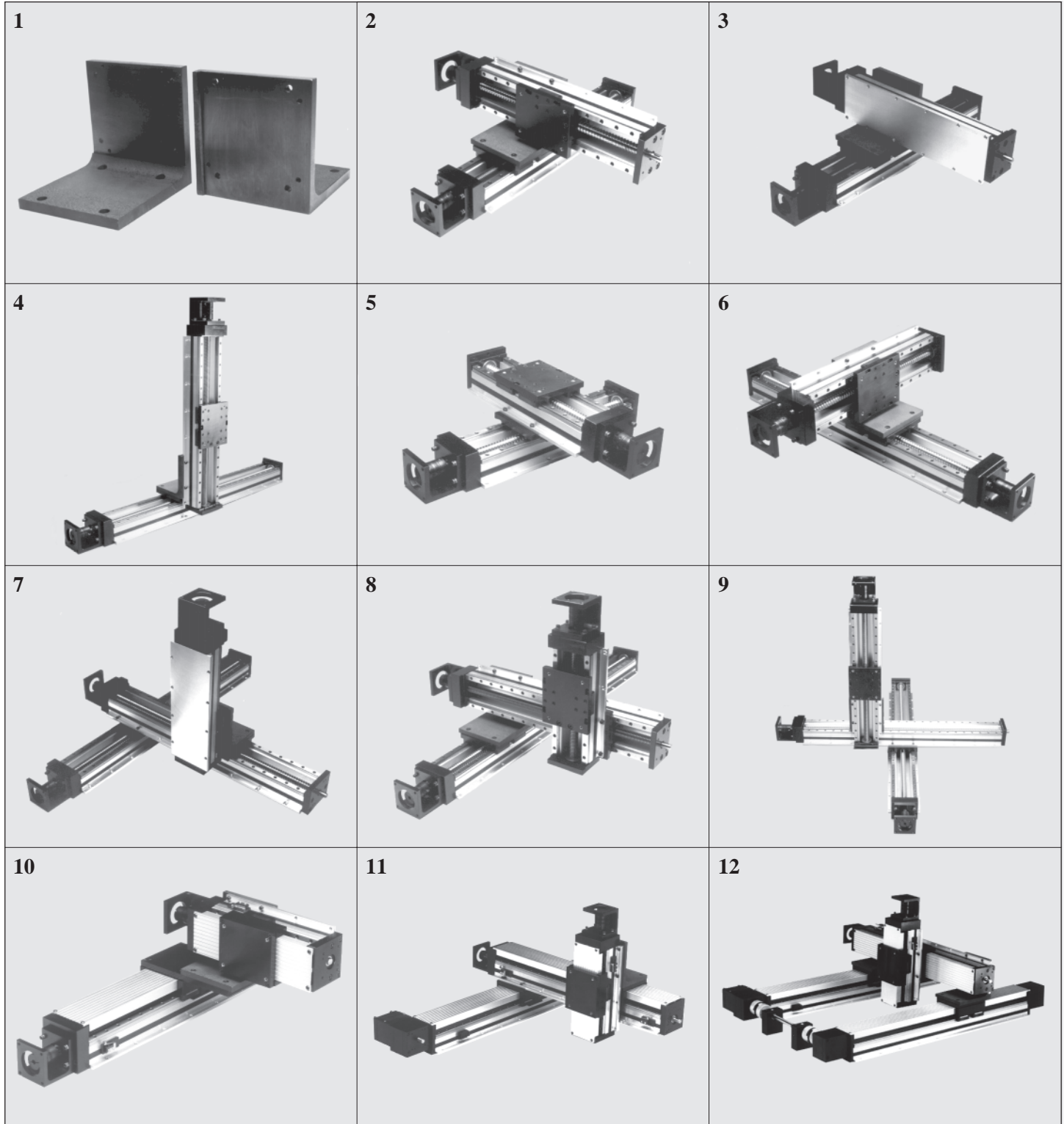

C

### NEMA 34 Motor Mount for 100 & 110 Series

The NEMA 34 motor adapter bracket is an aluminum flange that mounts to the front of the NEMA 23 motor mount. The bracket can be ordered in either an English, or Metric motor mount. *LINTECH* can provide adapter brackets for any step motor, or servo motor, that has other mounting requirements.

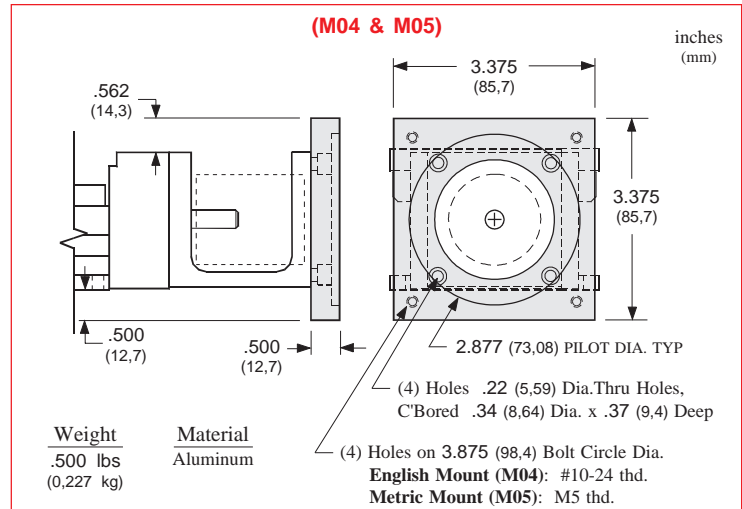

### Hand Crank for 100 & 110 Series

For manually operated applications, *LINTECH* provides a hand crank option for the 100 & 110 table series. The hand crank replaces the motor mount and coupling on the table.

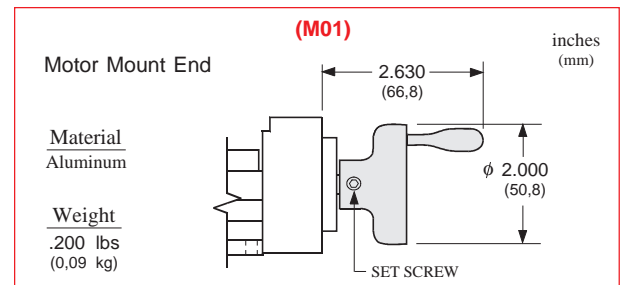

### NEMA 34 Motor Mount for 120 Series

A NEMA 34 aluminum motor adapter bracket can be mounted to the 120 series positioning table. The bracket can be ordered in either an English, or Metric motor mount. *LINTECH* can provide adapter brackets for any step motor, or servo motor, that has other mounting requirements.

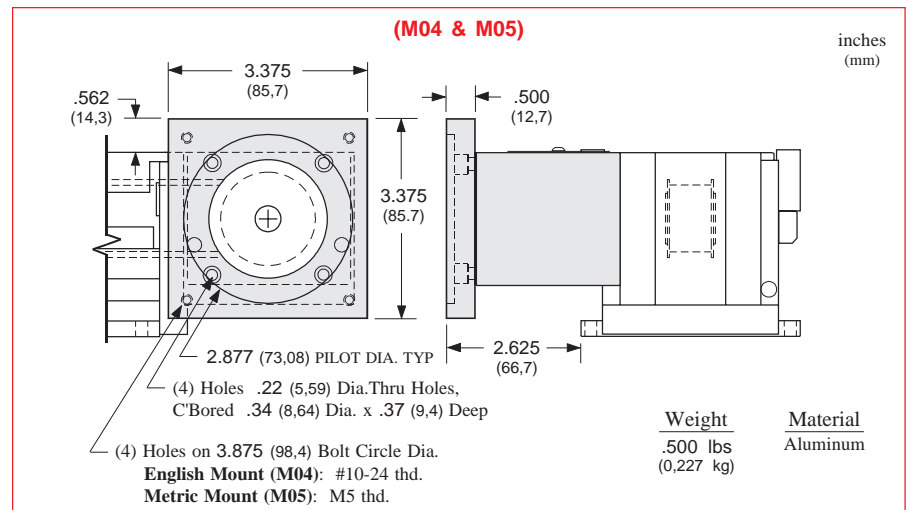

### Chrome Plated Linear Bearings, Rails, and Screws

For applications in high moisture, high humidity, clean room, or highly corrosive environments, chrome plating of the linear bearings, linear rails, and screw will offer superior resistance to corrosion than stainless steel components, resulting in longer table life. The process uniformly deposits dense, hard, high chromium alloy on the rails or screw, and has a Rockwell C hardness value of 67-72. This process also conforms to MIL Spec: (MIL-C-23422). The chrome plating bonds to the parent material and will not crack or peel off under the high point loading of balls on the rail, or screw. This chrome plating process differs from a normal hard chrome plate which just lays on the surface of the part plated.

Specifications subject to change without notice

### Motor Wrap Packages for 100 & 110 Series

For space limited 100 & 110 series applications, a belt and pulley system can couple the screw shaft extension to the motor shaft. This wraps the motor parallel to the table in order to decrease the overall positioning system length. Pulley weights and diameters are given in order to assist in calculating motor torque requirements.

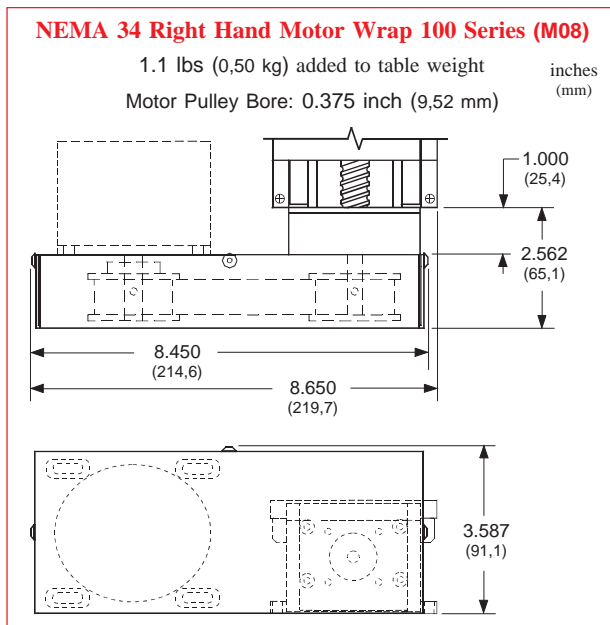
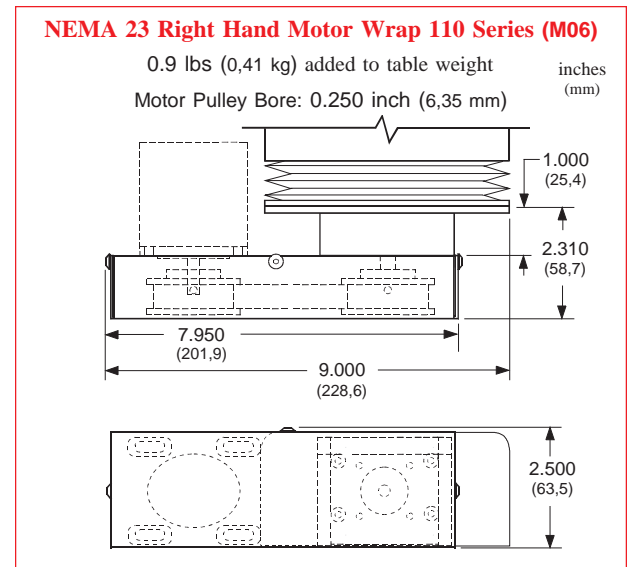
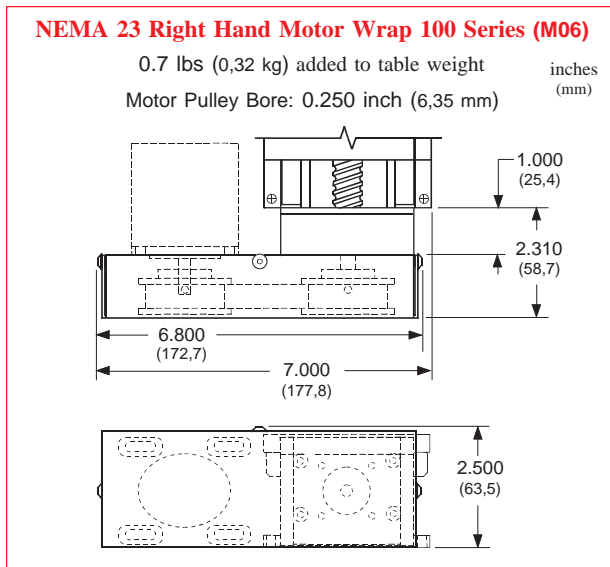

Motor Wrap Frame Size	Motor Pulley Dia. inches (mm)	Motor Pulley Wt. ounces (kg)	Screw Pulley Dia. inches (mm)	Screw Pulley Wt. ounces (kg)	Belt Weight ounces (kg)
<b>NEMA 23</b>	1.65 (41,9)	7.5 (0,21)	1.65 (41,9)	7.5 (0,21)	1.0 (0,028)
<b>NEMA 34</b>	1.65 (41,9)	8.0 (0,23)	1.65 (41,9)	8.0 (0,23)	1.2 (0,034)

**Note:** Right hand motor wraps shown. The left hand wrap packages orient the motor to the opposite side of the table. Motor pulley & belt shipped "loose". No motor mount nuts & bolts are provided. Custom motor wrap packages are available upon request. Other motor pulley bores MUST be specified for non-NEMA motors.

## Power-off Electric Brakes

For vertical table applications, or for those applications requiring the load to be locked securely in place, an electric brake may be mounted to the positioning table. The 100 or 110 series will have the brake mounted to the screw shaft extension located on the table end, opposite the motor mount bracket. The 120 series will have the brake mounted to the thru drive shaft option. With proper wiring from a control system, this power-off friction brake can ensure that the carriage is firmly held in place, when no electric power is applied to the brake. When power is applied to the brake, the brake is opened or "released".

For proper emergency braking of the positioning table, this electric brake needs to be interfaced to a position controller or relay network. *LINTECH* also provides 24 & 90 VDC power supplies which can be used to power the brakes.

## Brakes

Model Number	Holding Force in-lbs (N-m)	Excitation Voltage volts	Current amps	Weight lbs (kg)
<b>B01</b>	18 (2,0)	24 VDC	0.733	1.4 (0,62)
<b>B02</b>	18 (2,0)	90 VDC	0.178	1.4 (0,62)

**Note:** This power-off electric brake **MUST NOT** be engaged when the positioning table is in motion. Moving the table with the brake applied could damage the brake and the positioning table. Also, continuous use of this brake to stop a table (load) that is in motion could damage the brake and the positioning table. Dynamic braking of a positioning table should be done by the motor and not the brake.

## Power Supplies

Model Number	DC Output			AC Input		
	volts	amps	style	volts	amps	Hz
<b>41970</b>	5	3.0	regulated	120 / 240	0.8 / 0.4	47-63
<b>37488</b>	24	1.2	regulated	120 / 240	0.8 / 0.4	47-63
<b>37489</b>	90	0.8	unregulated	120	1.0	50/60
<b>37490</b>	90	0.8	unregulated	240	0.5	50/60

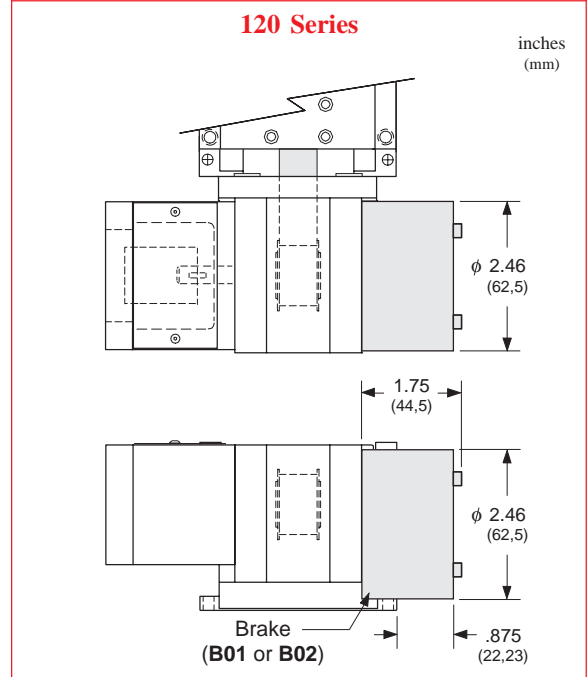
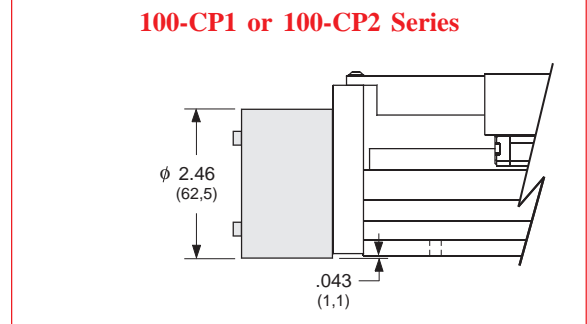
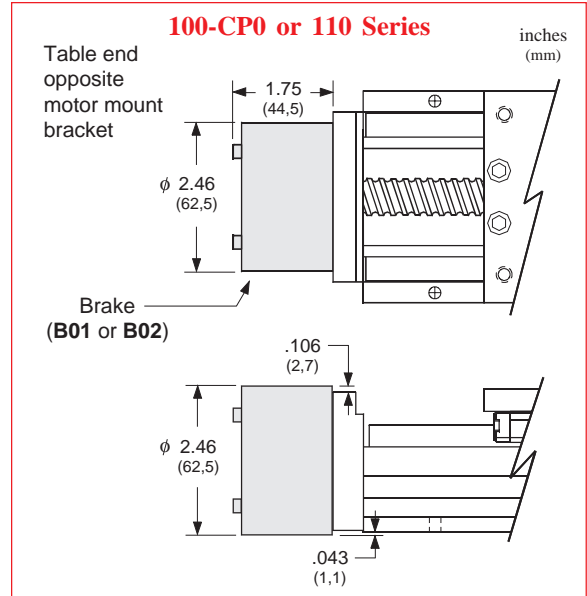

## Linear &amp; Rotary Incremental Encoders

Fully enclosed, incremental, optical linear encoders can be mounted along side any *LINTECH* 100 or 110 series table. Shaftless, incremental, optical rotary encoders can be mounted to the screw shaft extension opposite the motor mount end on the 100, 110 or 120 series positioning tables. These encoders provide positional feedback to either a motion controller, or a digital position display.

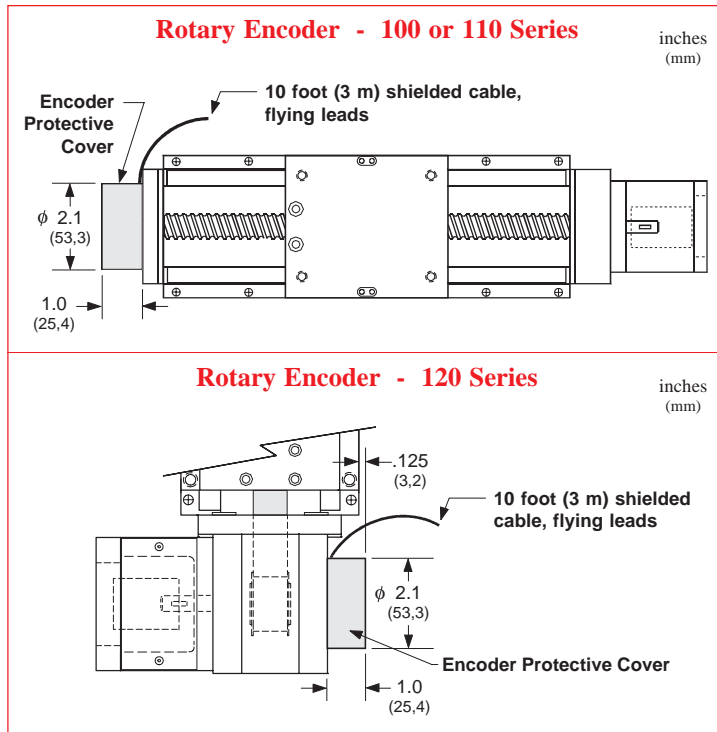

LINEAR		ROTARY	Description
Din Pin #	Wire Color	Wire Color	
C	Green	White	Channel A+ (or A)
D	Yellow	Blue	Channel A- (or $\bar{A}$ )
E	Pink	Green	Channel B+ (or B)
L	Red	Orange	Channel B- (or $\bar{B}$ )
G	Brown	White/Black	Channel Z+ (or Z)
H	Grey	Red/Black	Channel Z- (or $\bar{Z}$ )
A	Shield		Case ground
B	White	Black	Common
K	Black	Red	+ 5 vdc (+/- 5%)

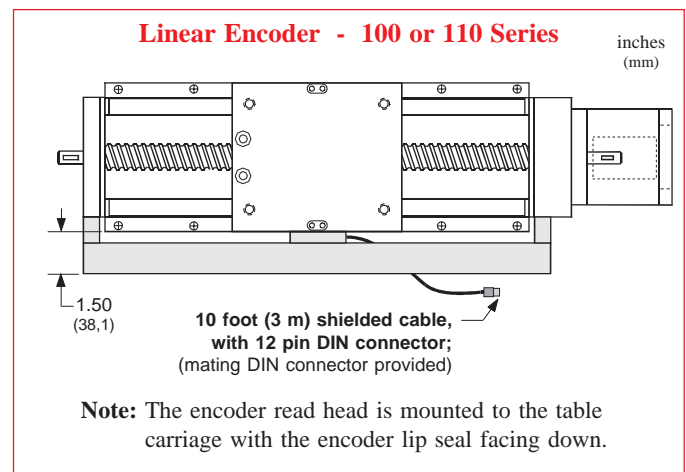

Specification	ROTARY ENCODERS			LINEAR ENCODERS	
	E01	E02	E03	E10	E11
<b>Line Count</b>	500 lines/rev	1000 lines/rev	1270 lines/rev	2500 lines/inch	125 lines/mm
<b>Pre Quadrature Resolution</b>	0.002 revs/pulse	0.001 revs/pulse	0.00079 revs/pulse	0.0004 inch/pulse	8 microns/pulse
<b>Post Quadrature Resolution</b>	0.0005 revs/pulse	0.00025 revs/pulse	0.00019 revs/pulse	0.0001 inch/pulse	2 micron/pulse
<b>Accuracy</b>				+/- 0.0002 in/40"	+/- 5 microns/m
<b>Maximum Speed</b>	50 revs/sec			79 inches/sec	2 m/sec
<b>Maximum Accel</b>	40 revs/sec <sup>2</sup>			130 ft/sec <sup>2</sup>	40 m/sec <sup>2</sup>
<b>Excitation Power</b>	+ 5 VDC @ 125 ma			+ 5 VDC @ 150 ma	
<b>Operating Temperature</b>	32°F to 140°F (0°C to 60°C)			32°F to 120°F (0°C to 50°C)	
<b>Humidity</b>	20% to 80% non condensing			20% to 80% non condensing	
<b>Shock</b>	10 G's for 11 msec duration			15 G's for 8 msec duration	
<b>Weight</b>	0.7 lbs (0,283 kg)			0.7 oz/inch (0,00078 kg/mm) length of scale + 0.5 lbs (0,23 kg) read head and brackets	
<b>Cable Length</b>	10 ft (3 m), unterminated 26 gauge leads			10 ft (3 m) with DIN connector	
<b>Zero Reference Output</b>	Once per revolution			At center of encoder length	
<b>Outputs</b>	TTL square wave; Two channel (A+ & B+); Differential (A- & B-); Line Driver				

Specifications subject to change without notice

